

TECHNICAL MANUAL

OPERATOR'S MANUAL

WATER PURIFICATION UNIT,  
REVERSE OSMOSIS,  
600 GPH TRAILER MOUNTED  
FLATBED CARGO,  
5 TON 4 WHEEL TANDEM  
MODEL 0996109001  
(4610-01-234-2196)

AND

600 GPH SKID MOUNTED  
MODEL 0996108001  
(4610-01-234-2190)

TABLE OF CONTENTS	i	
EQUIPMENT DESCRIPTION	1-1	
OPERATING INSTRUCTION	2-1	
PREVENTIVE MAINTENANCE	2-18	
LUBRICATION INSTRUCTION	3-1	
TROUBLESHOOTING PROCEDURES	3-1	
MAINTENANCE PROCEDURES	3-16	
SUBJECT INDEX	Index-1	

Approved for public release; distribution is unlimited.

\*This manual, together with TM 10-4610-215-10/TM 08580A-10/1 and  
TM 10-4610-240-10/ TO 40W4- 13-21, supersedes  
TM 5-4610-215-10/TM08580A-10/1, 15 May 1987. Including all changes.

HEADQUARTERS, DEPARTMENT OF THE ARMY  
AND HEAD QUARTERS, U.S. MARINE CORPS  
5 MARCH 1991

HEADQUARTERS, DEPARTMENTS OF  
THE ARMY AND HEADQUARTERS, MARINE CORPS  
WASHINGTON, D.C., 28 February 1995

CHANGE

No 2

**Operator's Manual**

**Water Purification Unit, Reverse Osmosis  
600 GPH Trailer Mounted, Flatbed Cargo,  
5 Ton 4 Wheel Tandem, Model 0996109001  
(4610-01-2324-2196)  
and  
600 GPH Skid Mounted, Model 0996108001  
(4610-01-234-2190)**

DISTRIBUTION STATEMENT A: Approved for public release; distribution is unlimited

TM 10-4610-239-10/TM 08580B-10/1, 5 March 1991, is changed as follows:

1. Remove and insert pages as indicated below. New or changed text material is indicated by a vertical bar in the margin. An illustration change is indicated by a miniature pointing hand.

Remove pages  
i and ii  
1-1 and 1-2  
B-3 and B-4

Insert pages  
i and ii  
1-1 and 1-2  
B-3 and B-4

2. Retain this sheet in front of manual for reference purposes.

By Order of the Secretary of the Army:

Official:   
MILTON H. HAMILTON  
Administrative Assistant to the  
Secretary of the Army  
0e117

GORDON R. SULLIVAN  
General, United States Army  
Chief of Staff

By Order of the Secretaries of the Army and Navy (Including the Marine Corps):

**D. R. BLOOMER**  
Colonel, USMC  
Director, Program Support  
Marine Corps Systems Command

J. E. BUFFINGTO  
Rear Admiral, CEC, US Navy  
Commander  
Navy Facilities Engineering  
Command

**DISTRIBUTION:**

To be distributed in accordance with DA Form 12-25-E, block no. 4487, requirements for  
TM 10-4610-239-10.

CHANGE

HEADQUARTERS,  
DEPARTMENTS OF THE ARMY,  
AND HEADQUARTERS U.S. MARINE CORPS  
WASHINGTON, D.C., 1 February 1994

NO. 1

**Operator's Manual**

**WATER PURIFICATION UNIT, REVERSE OSMOSIS,  
600 GPH TRAILER MOUNTED  
FLATBED CARGO,  
5 TON 4 WHEEL TANDEM  
MODEL 0996109001  
(4610-01-234-2196)**

**AND**

**600 GPH SKID MOUNTED  
MODEL 0996108001  
(4610-01-234-2190)**

**DISTRIBUTION STATEMENT A: Approved for public release; distribution is unlimited**

TM 10-4610-239-1 0/TM 08580B-10/1, 5 March 1991, is changed as follows:

1. Remove and insert pages as indicated below. New or changed text material is indicated by a vertical bar in the margin. An illustration change is indicated by a miniature pointing hand.

Remove pages

Insert pages

D-1 through D-3/(D-4 blank)

D-1 through D-3/(D-4 blank)

- 2 Retain this sheet in front of manual for reference purposes.

**By Order of the Secretaries of the Army and Navy (Including the Marine Corps):**

Official:

MILTON H. HAMILTON  
Administrative Assistant to the  
Secretary of the Army  
os161

GORDON R. SULLIVAN  
General, United States Army  
Chief of Staff

**DAVID E BOTTORFF**  
Rear Admiral, CEC, US Navy  
Commander  
Navy Facilities Engineering  
Command

**D. R. BLOOMER**  
Colonel, USMC  
Director, Program Support  
Marine Corps Systems Command

**DISTRIBUTION:**

To be distributed in accordance with DA Form 12-25-E, block no. 4487, requirements for TM 10-4610-239-10.

**WARNING**

ELECTRICAL HIGH VOLTAGE CAN KILL YOU

Electrical high voltage cannot be seen but it can kill you. Electricity is unlike most other dangerous things you can come in contact with because it gives no warning and no symptoms to be wary of. Its effect is immediate. It can kill you, render you unconscious, or severely burn you. To ensure your safety and that of other maintenance personnel, always observe the following precautions:

DO NOT perform any maintenance on electrical equipment unless all power is removed.

DO NOT perform any maintenance on electrical equipment that must have power applied during maintenance without proper insulation between you and the equipment at all times.

BE CERTAIN that there is someone assisting you who can remove power immediately.

ALWAYS place POWER OFF warning tags on power supply switches so that no one will apply power while you are performing maintenance.

ALWAYS make sure the unit is properly grounded.

FOR ARTIFICIAL RESPIRATION, REFER TO FM 21-11

**WARNING**

DANGEROUS CHEMICALS CAN KILL YOU

The chemicals used for operation in the ROWPU can kill you. Breathing some of the chemicals used in the ROWPU system can cause severe headaches, dizziness, loss of muscular control, a sleepy feeling and coma. Brain damage, eye injury, severe skin damage, or death can result from heavy exposure. The chemicals alone or in a mixture can be very dangerous without good air movement. These precautions must be followed to ensure safety when handling or mixing chemicals:

ALWAYS wear protective clothing while handling dangerous chemicals.

NEVER get too close to or breathe dangerous chemicals.

ALWAYS make certain that a good clean water supply is available to flush away any chemicals that might come in contact with the body.

BE alert at all times during operation for chemical odors and exposure symptoms. If either is present, IMMEDIATELY VENTILATE personnel compartments. If symptoms persist, remove personnel to fresh air.

WARNING

NOISE

Operating level of this generator can cause hearing damage. Ear protectors, as recommended by the medical or safety officer, must be worn when working near this set.

WARNING

Generator sets must not be operated in enclosed areas unless exhaust discharge is properly vented to the outside. Be alert at all times during operation for odors and exposure symptoms.

**b**

**TECHNICAL MANUAL**

HEADQUARTERS, DEPARTMENT OF THE ARMY AND  
HEADQUARTERS, U.S. MARINE CORPS  
WASHINGTON, D.C., 5 MARCH 1991

No. 10-4610-239-10  
TM 08580B-10n

**Operator's Manual**

WATER PURIFICATION UNIT, REVERSE OSMOSIS  
600 GPH TRAILER MOUNTED, FLATBED CARGO,  
5 TON 4 WHEEL TANDEM ROWPU MODEL 0996109001 (4610-01-234-2196)  
AND 600 GPH SKID MOUNTED ROWPU MODEL 0996108001 (4610-01-234-2190)

**REPORTING ERRORS AND RECOMMENDING IMPROVEMENTS**

You can help improve this manual. If you find any mistakes or if you know of a way to improve the procedures, please let us know. Mail your letter, DA Form 2028 (Recommended Changes to Publications and Blank Forms), or DA Form 2028-2 located in the back of this manual directly to:

Commander, U.S. Army Aviation and Troop Command, ATTN: AMSAT-I-MP, 4300 Goodfellow Boulevard, St. Louis, MO 63120-1798. A reply will be furnished directly to you.

Marine Corps users submit NAVMC 10772 Form to Commanding General, Marine Corps Logistics Base (Code 850) Albany, Georgia 31704-5000.

**DISTRIRUTION STATFMFNT A: Approved for public release; distribution is unlimited.**

**TABLE OF CONTENTS**

	<b>Page</b>
CHAPTER 1 INTRODUCTION	
Section I. General Information .....	1-1
Section II. Equipment Description .....	1-1
Section III. Technical Principles of Operation .....	1-17
CHAPTER 2 OPERATING INSTRUCTIONS	
Section I. Description and Use of Operator's Controls and Indicators .....	2-1
Section II. Preventive Maintenance Checks and Services .....	2-18
Section III. Operation Under Usual Conditions .....	2-31
Section IV. Operation Under Unusual Conditions .....	2-99
CHAPTER 3 MAINTENANCE INSTRUCTIONS	
Section I. Lubrication Instructions .....	3-1
Section II. Troubleshooting Procedures .....	3-1
Section III. Maintenance Procedures .....	3-16

This manual, together with TM 10-4610-215-10/TM 08580A-10/1 and TM 1 04610-240-1 /TM 08580C-1 0/1/TO 40W4-13-21, supersedes TM 5-4610-215-1 0/TM08580A-10/1, 15 May 1987, including all changes.



<b>CHAPTER 4</b>	<b>MAINTENANCE OF AUXILIARY EQUIPMENT</b>	
APPENDIX A	REFERENCES .....	A-1
APPENDIX B	COMPONENTS OF END ITEM AND BASIC ISSUE ITEMS LIST .....	B-1
APPENDIX C	ADDITIONAL AUTHORIZATION LIST .....	C-1
APPENDIX D	EXPENDABLE/DURABLE SUPPLIES AND MATERIALS LIST.....	D-1
SUBJECT INDEX .....		INDEX-1

LIST OF ILLUSTRATIONS

Figure	Title	Page
1-1	Reverse Osmosis Water Purification Unit (ROWPU) (Army) .....	1-0
1-2	Reverse Osmosis Water Purification Unit (ROWPU) (MC) .....	1-0
1-3	Top View of ROWPU With Operating Equipment Stored (Army) .....	1-3
1-4	Top View of ROWPU With Operating Equipment Stored (MC) .....	1-3
1-5	Top View of ROWPU With Pumps (Army) .....	1-4
1-6	Top View of ROWPU With Pumps (MC) .....	1-5
1-7	Top View of ROWPU With Operating Equipment Removed (Army) .....	1-6
1-8	Top View of ROWPU With Operating Equipment Removed (MC) .....	1-7
1-9	Control Panel Side of ROWPU .....	1-8
1-10	Hoses and Storage Boxes.....	1-10
1-11	Raw Water and Backwash Pumps .....	1-11
1-12	Distribution Pump and Chemical Cans .....	1-11
1-13	ROWPU - Generator Removed (Rear View) .....	1-12
1-14	ROWPU Flatbed Trailer and Frame (Army Model No. 0996109001) .....	1-14
1-15	Water Processing Block Diagram .....	1-18
2-1	Electrical Plug.....	2-1
2-2	Air Hose Glad-Hand Connectors .....	2-1
2-3	Water Meter .....	2-3
2-4	Controls and Indicators: Control Panel (Sheet 1 of 3).....	2-4
2-4	Controls and Indicators: Control Panel (Sheet 2 of 3).....	2-5
2-4	Controls and Indicators: Control Panel (Sheet 3 of 3).....	2-6
2-5	Vent Vessels Valve .....	2-11
2-6	Vent Product Water Valve .....	2-11
2-7	Chemical Feed Pump Controls .....	2-12
2-8	Gate Valves.....	2-12
2-9	Drain Valves.....	2-13
2-10	Chemical Feed Pump Valves.....	2-13
2-11	Total Dissolved Solids (TDS) Meter (Portable).....	2-14
2-12	Total Dissolved Solids (TDS) Meter (In-Line).....	2-14
2-13	Turgidity Tube .....	2-16
2-14	Color Comparator Kit.....	2-17
2-15	Backwash Timer.....	2-18
2-16	Site Diagram.....	2-31
2-17	Preparation For Use (Sheet 1 of 4) (Army Model No. 0996109001).....	2-32
2-17	Preparation For Use (Sheet 2 of 4) (Army Model No. 0996109001).....	2-33
2-17	Preparation For Use (Sheet 3 of 4) (Army Model No. 0996109001).....	2-34
2-17	Preparation For Use (Sheet 4 of 4) (Army Model No. 0996109001).....	2-35
2-18	Unfold Safety Step (Army).....	2-36
2-19	Canvas Cover Tied Back.....	2-36
2-20	Top View of ROWPU. ....	2-37
2-21	Cross Braces, Cargo Straps, Ratchets .....	2-37
2-22	Suction Hose Float and Utility Pails.....	2-38
2-23	Rubber Hoses. ....	2-38
2-24	Top View of ROWPU and Overtake.....	2-39
2-25	Storage Box No. 2. ....	2-40
2-26	Storage Box No. 3.....	2-40

LIST OF ILLUSTRATIONS (continued)

Figure	Title	Page
2-27	Outboard Pumps .....	2-40
2-28	Total Dissolved Solids (TDS) Meter (Portable) .....	2-41
2-29	In-Line TDS Monitor Location.....	2-42
2-30	Typical Field Installation .....	2-43
2-31	Typical Water Tank Installation .....	2-44
2-32	Raw Water System .....	2-45
2-33	Backwash Pump and Strainer.....	2-46
2-34	Backwash Water System .....	2-47
2-35	Product Water System .....	2-48
2-36	Waste Water System .....	2-49
2-37	Wood Paddles and Chemical Tubes.....	2-49
2-38	Tubes Attached to Chemical Feed Pump .....	2-50
2-39	Ground Rod in Stowed Position .....	2-53
2-40	Junction Box.....	2-54
2-41	Drain Valves (During Operation) .....	2-55
2-42	Vent Valves .....	2-55
2-43	Vent Product Water Valve .....	2-56
2-44	Backwash Valve .....	2-56
2-45	Product Flow Valve.....	2-57
2-46	Control Box Switches .....	2-57
2-47	Element Cleaning Switch .....	2-58
2-48	Raw Water Pump (Prime and Drain) .....	2-58
2-49	High Pressure Relief Valve and Rupture Disc.....	2-59
2-50	Emergency Stop Button .....	2-60
2-51	High/Low Pressure Lamps .....	2-61
2-52	Switches (Pump Controls).....	2-61
2-53	Output Hose - Raw Water Pump No. 2 .....	2-62
2-54	Chemical Feed Pump Start Switch.....	2-63
2-55	Control Knobs.....	2-64
2-56	Multimedia Filter Vent Valve.....	2-65
2-57	Booster Pump Switch .....	2-65
2-58	Cartridge Filter Vent Valve .....	2-66
2-59	Controls, R.O. Pump .....	2-66
2-60	R.O. Pump and Motor .....	2-67
2-61	Pulse Dampened Vent Valve .....	2-67
2-62	R.O. Vessel .....	2-68
2-63	Vent Vessels Valve .....	2-68
2-64	Turgidity Tube .....	2-69
2-65	Drain Valves .....	2-69
2-66	Nameplates .....	2-70
2-67	R.O. Pressure and Product Water Flow Gages .....	2-71
2-68	Product Water Flow Gages and Pressure.....	2-72
2-69	Brine Water Shutoff Valve.....	2-73
2-70	R.O. Pump Low Pressure Lamp. ....	2-74
2-71	R.O. Pump High Pressure Lamp.....	2-74
2-72	Distribution Pump Switch .....	2-75

**LIST OF ILLUSTRATIONS (continued)**

<b>Figure</b>	<b>Title</b>	<b>Page</b>
2-73	Solid-State Timer (Pilot Control Valve).....	2-76
2-74	Solid-State Timer (Subpanel and Rotary Switches).....	2-77
2-75	Backwash Water Tank .....	2-80
2-76	Product Water Flow Indicator.....	2-82
2-77	R.O. Pressure Gage.....	2-82
2-78	Product Water Totalizer .....	2-83
2-79	Shutdown Position of Control Panel Switches and Valves.....	2-84
2-80	Total Dissolved Solids (TDS) Meter .....	2-86
2-81	Preparation for Movement (Sheet 1 of 7) (Army Model 0996109001 .....	2-92
2-81	Preparation for Movement (Sheet 2 of 7) (Army Model 0996109001) .....	2-93
2-81	Preparation for Movement (Sheet 3 of 7) (Army Model 0996109001) .....	2-94
2-81	Preparation for Movement (Sheet 4 of 7) (Army Model 0996109001) .....	2-95
2-81	Preparation for Movement (Sheet 5 of 7) (Army Model 0996109001) .....	2-96
2-81	Preparation for Movement (Sheet 6 of 7) (Army Model 0996109001) .....	2-97
2-81	Preparation for Movement (Sheet 7 of 7) (Army Model 0996109001) .....	2-98
2-82	Resetting Locked Spring Brake (Army).....	2-100
2-83	Nuclear and Chemical Filter Installation.....	2-105
3-1	R.O. Vessel End Cap Assembly Removal .....	3-16
3-2	R.O. Vessel Element Puller.....	3-17
3-3	R.O. Vessel Element Puller Assembly .....	3-18
3-4	Pulling Element From R.O. Vessel.....	3-19
3-5	R.O. Vessel (Exploded View) .....	3-20
3-6	Element Replacement.....	3-21
3-7	Element Replacement.....	3-22
3-8	Element Replacement.....	3-22
3-9	Element Replacement.....	3-23
3-10	Cartridge Filter Assembly (Model Nos. 0996108001 and 0996109001) .....	3-24
3-11	Cartridge Filter End Cover Eye (Nut Tightening Sequence) .....	3-25
3-12	Backwash Pump Strainer .....	3-26
3-13	R.O. Pump Rupture Disk and Holder .....	3-27
3-14	Total Dissolved Solids (TDS) Meter (Portable) Battery Replacement.....	3-29
3-15	Switch Indicator Lamp Replacement.....	3-30
3-16	Panel Lamp Replacement.....	3-31

LIST OF TABLES

Table	Title	Page
2-1	Water Processing Controls and Indicators.....	2-7
2-2	(Army) Operator/Crew Preventive Maintenance Checks and Services (Trailer).....	2-20
2-3	Operator/Crew Preventive Maintenance Checks and Services (Unit) .....	2-22
2-4	Gage Readings, Normal and Trouble-point .....	2-73
2-5	Shutdown Position of Valve or Switch.....	2-85
3-1	(Army) Troubleshooting.....	3-1
3-2	Troubleshooting (ROWPU) .....	3-4

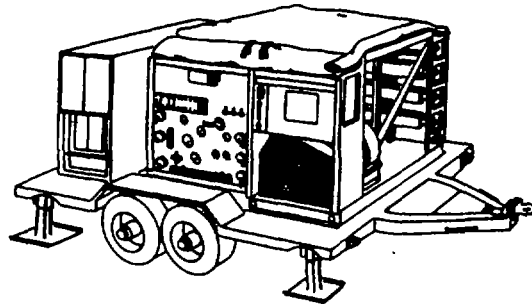

Figure 1-1. Reverse Osmosis Water Purification Unit (ROWPU) (Army)

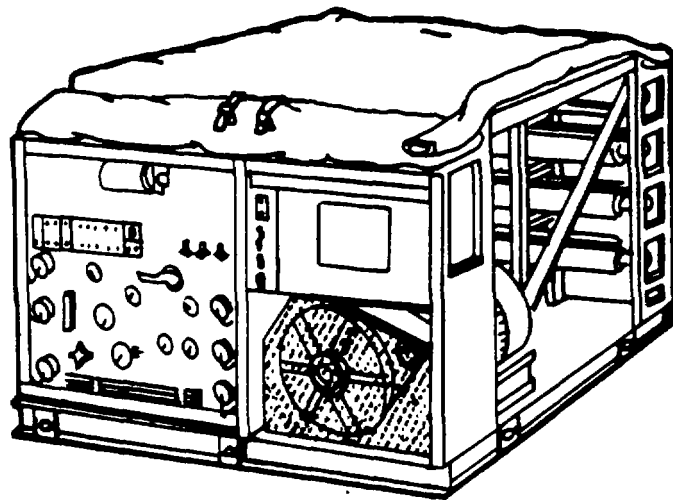

Figure 1-2. Reverse Osmosis Water Purification Unit (ROWPU) (MC)

## CHAPTER 1

### INTRODUCTION

#### SECTION I. GENERAL INFORMATION

**1-1. SCOPE.** This operator's manual describes the Operating and Operator's Maintenance Procedures for the 600 Gallon Per Hour (GPH) Reverse Osmosis Water Purification Unit (ROWPU). It should be noted that although a complete 600 GPH Reverse Osmosis Water Purification Equipment Set is described herein, certain components are not issued under the National Stock Number NSN 4610-01 -234-2196, but are authorized (Army) under their own TOE Line Item Numbers and are listed in the Department of the Army Supply Catalog SC 4610-97-CL-E16 which describes the entire 600 GPH ROWPU Set. NSN 4610-01-234-2190 is the Marine Corps ROWPU designation.

#### NOTE

Paragraphs not designated Army or MC are applicable to both configurations.

**1-2. MAINTENANCE FORMS AND RECORDS.** Good maintenance records must be kept. Department of Army forms and procedures used for equipment maintenance will be those prescribed by DA PAM 738-750, The Army Maintenance Management System (TAMMS). Marine Corps personnel refer to TM 4700-15/1 for forms and records procedures.

**1-3. HAND RECEIPT.** (Army) A companion hand receipt technical manual has been issued with the ROWPU to aid in accounting for all of the end-item related equipment. The hand receipt manual is numbered with TM number of this manual (TM 10-4610-239-10) followed by '-HR'. Hand Receipt Manual TM 10-4610-239-10-HR contains pre-printed hand receipts for Components of End Item (COEI), Basic Issue Items (BII), and Additional Authorization List (AAL) items. Additional -HR manuals may be obtained from the U.S. Army Adjutant General Publications Center, ATTN: AGDL-OD, 2800 Eastern Blvd., Baltimore, MD 21220, in accordance with the procedures in Chapter 3, AR 310-2.

**1-4. REPORTING EQUIPMENT IMPROVEMENT RECOMMENDATIONS (ER's).** If your ROWPU needs improvement, let us know. Send us an EIR. You, the user, are the only one who can tell us what you do not like about your equipment. Let us know why you do not like the design. Tell us why a procedure is hard to perform. Put it on an SF-368 (Quality Deficiency Report). Mail it to us at:

Commander  
US Army Aviation and Troop Command  
ATTN: AMSAT-I-MDO  
4300 Goodfellow Blvd.  
St. Louis, MO 63120-1798

Marine Corps personnel submit EIR's in accordance with MCO 1650.17.

#### SECTION II. EQUIPMENT DESCRIPTION

##### 1-5. EQUIPMENT CHARACTERISTICS, CAPABILITIES, AND FEATURES

a. Characteristics. The ROWPU is a mobile water purifying unit needing a 30 kW power source, that supplies drinking water for troops in the field. (See fig. 1-1 (Army) and fig. 1-2 (MC)).

**b. Capabilities and Features.**

(1) Flow systems within the ROWPU process raw water to make it drinkable. Special pumps, controlled by a built-in control panel, move the water through the ROWPU to produce as much as 10 gallons (37.8 liters) of drinking water per minute. This water is stored in a collapsible tank that can hold up to a total of 1,500 gallons (5,670 liters) or 3,000 gallons (11,340 liters). The ROWPU can be transported by rail, road, or air.

(2) (Army) The flatbed cargo trailer and frame is designed to provide a mobile platform for the ROWPU. The trailer, when being transported by road, is towed by a towing vehicle through a lunette/pintle hookup. The trailer has four leveling jacks (square Model No. 0996109001 ) with swivels, one on each corner, and is equipped with a spare wheel and tire carrier. The trailer incorporates service brakes which are air-actuated and operated from the towing vehicle through an integral set of hoses. The trailer brake system also includes emergency and automatic parking brake functions that are activated when the air hoses are disconnected from the towing vehicle. An air tank is installed for the purpose of reserving air for this system when the trailer is disconnected from the towing vehicle. A 24-volt electrical system, consisting of one composite blackout-stoplight assembly, and two stoplight-tail light assemblies, is installed on the trailer. Power is supplied through a cable connected to the electrical system of the towing vehicle. The trailer suspension consists of two axles in tandem, supported on leaf springs attached to a trunnion axle. The frame houses the ROWPU and is capable of being separated from the trailer and transported or air lifted as an independent unit.

(3) The Army and Marine Corps units are essentially the same except that the Marine Corps' ROWPU is mounted on a skid and does not incorporate a generator.

**1-6. LOCATION AND DESCRIPTION OF MAJOR COMPONENTS.** The Army ROWPU is 18 feet (5.5 meters) long, 8 feet (2.4 meters) high, and 8 feet (2.4 meters) wide. It weighs about 8 ½ tons (7.71 metric tons), including the generator set. Figure 1-3 shows the ROWPU from the top with its canvas cover removed. Take a close look at how all the necessary operating equipment is stored on the trailer for transport and shipment.

The Marine Corps ROWPU is 9.5 feet (2.9 meters) long, 5.6 feet (1.7 meters) high and 6.9 feet (2.1 meters) wide. It weighs about 3.65 tons (3 metric tons). Figure 1-4 shows this ROWPU from the top with the canvas cover removed.

a. To provide room for all operating components, material is stored in layers (fig. 1-3 and 1-4). The top layer consists of rolled-up (suction) hoses on top of two folded water tanks. Stored between the tanks is a sledge hammer and a collapsed telescopic aluminum paddle. Next to the tanks is a stack of five plastic pails with chemical names on their sides. On the same side of the ROWPU you will find two storage boxes fastened with a strap under the tanks. The boxes contain various chemicals, tools, and installation items. Nine sections of suction hose are stored on the side of the frame.

b. In the second layer you will find two raw water pumps and a backwash pump (fig. 1-5 and 1-6). The pumps are covered with canvas and strapped down. A distribution pump is located at the rear of the unit, next to the generator (Army ROWPU only), not shown here. Army ROWPU includes a portable step strapped down with distribution pump. On the right side are 1 ½ inch and 2-inch diameter discharge (canvas) hoses, rolled-up. A raw water float is in the center of the ROWPU next to two nuclear, biological, chemical (NBC) cylinders. Figs. 1-7 and 1-8 show ROWPU with operating equipment removed.



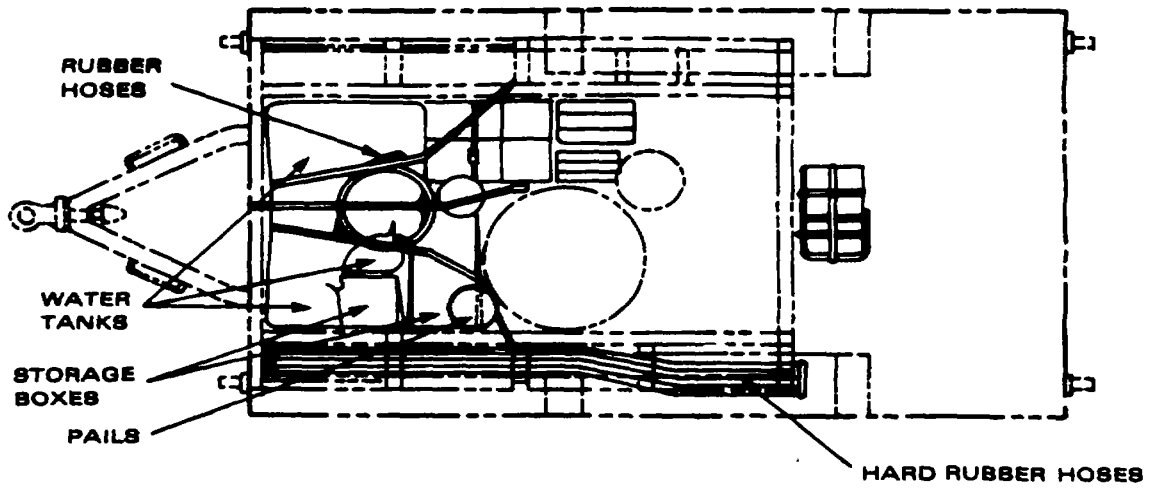

Figure 1-3. Top View Of ROWPU With Operating Equipment Stored (Army)

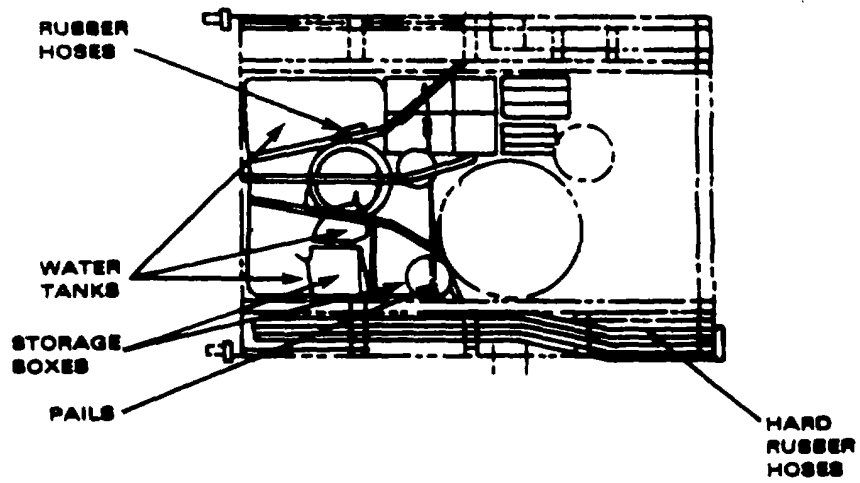

Figure 1-4. Top View Of ROWPU With Operating Equipment Stored (MC)

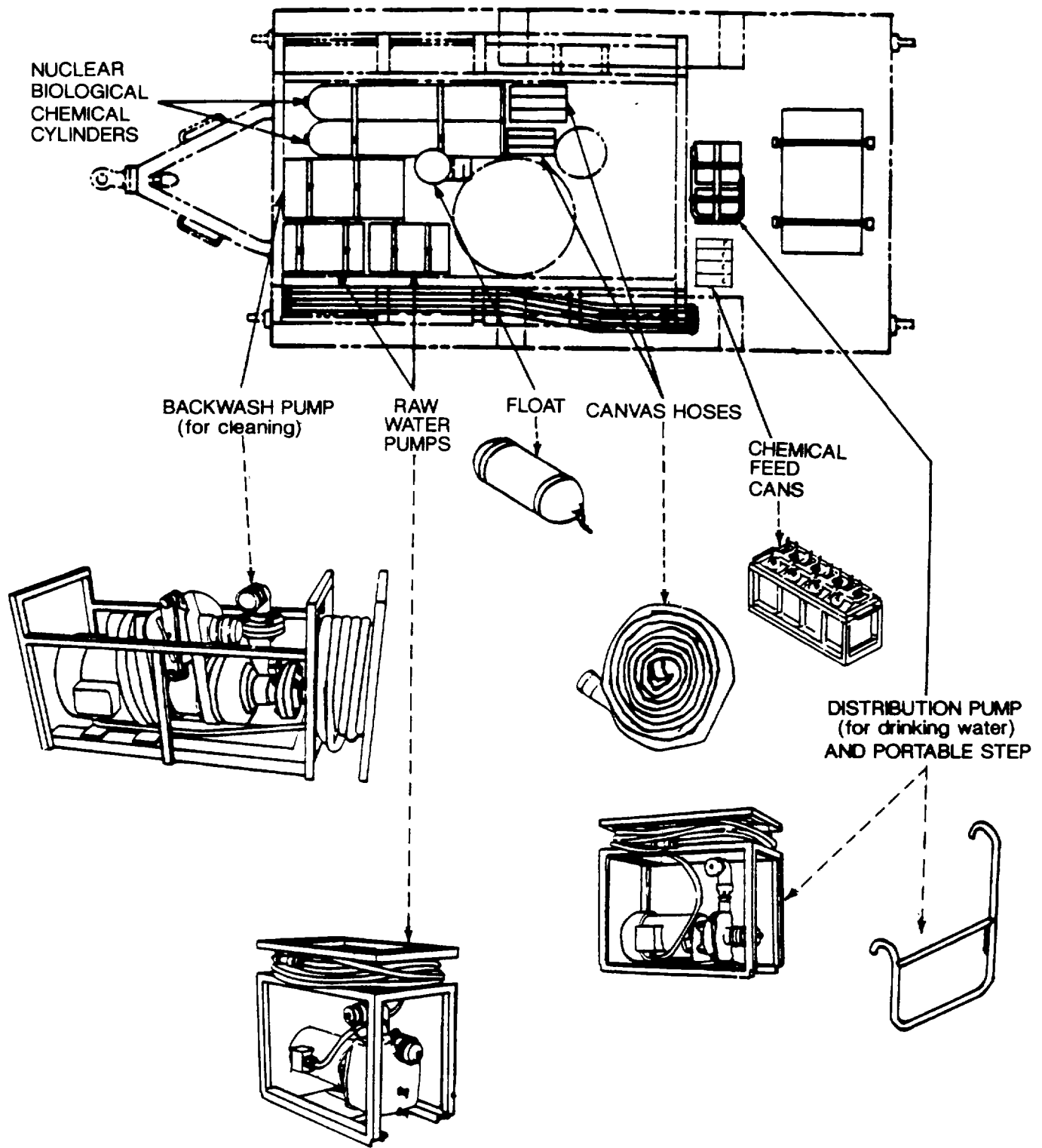

Figure 1-5. Top View of ROWPU With Pumps (Army)

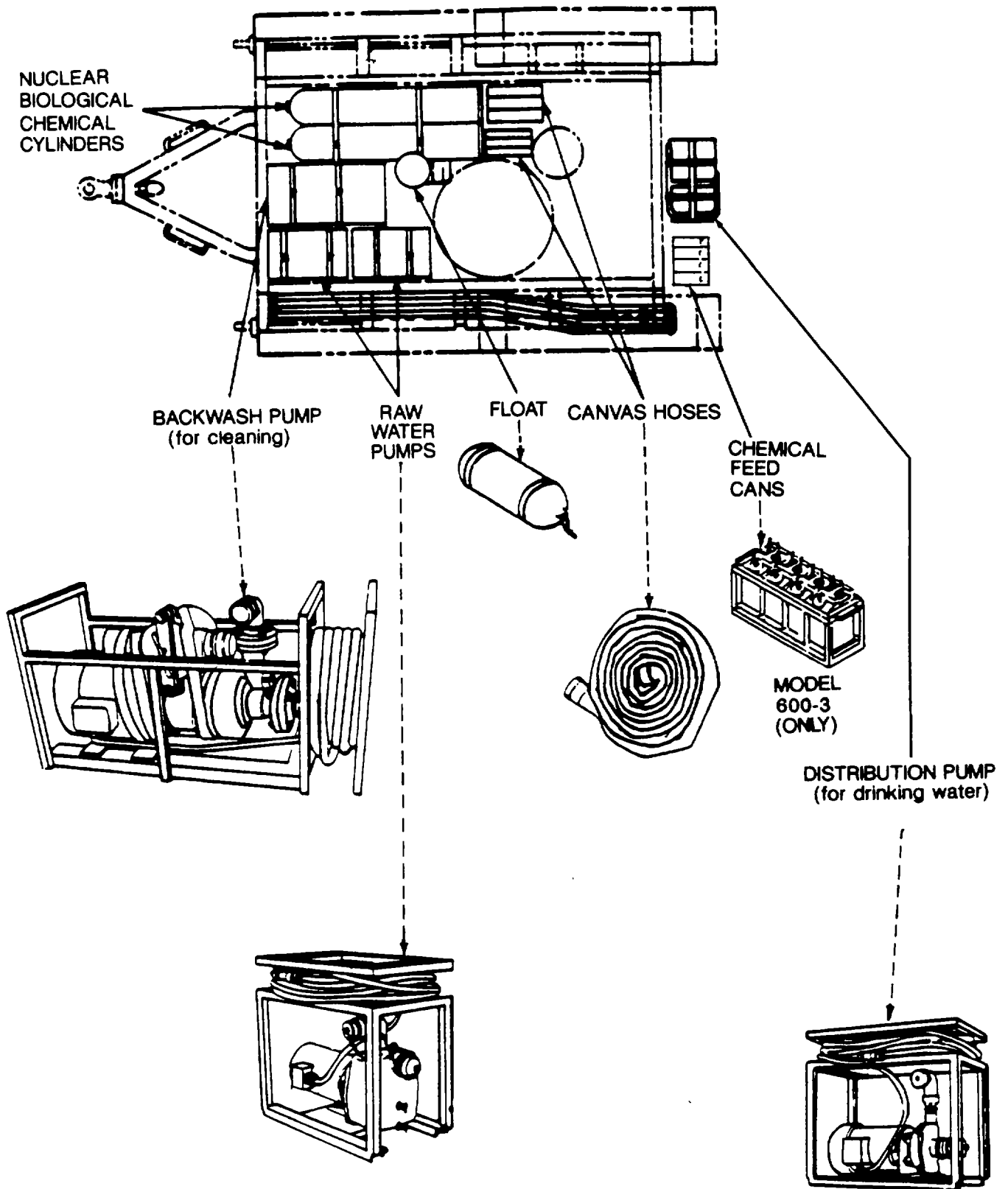

Figure 1-6. Top View of ROWPU With Pumps (MC)

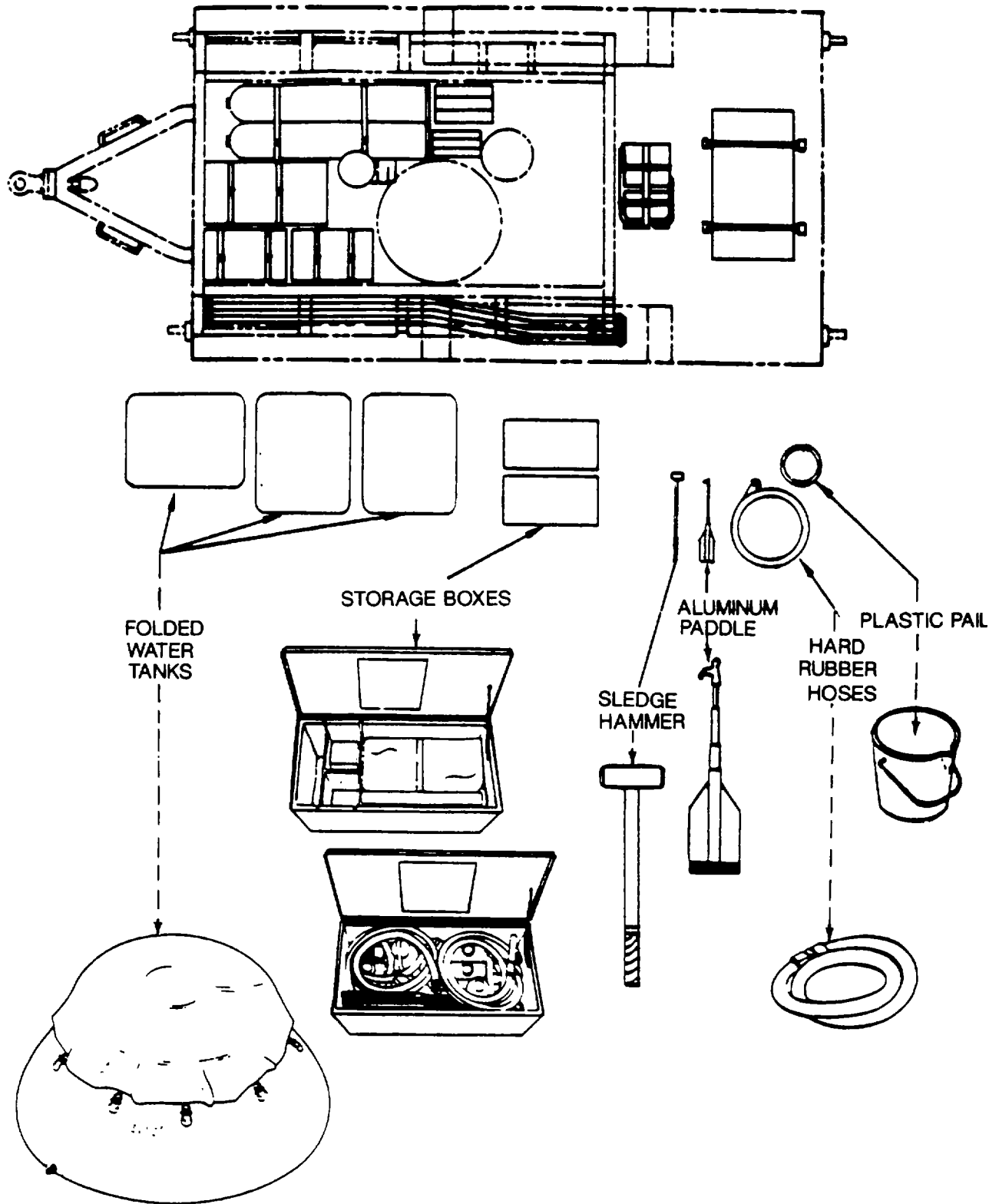

Figure 1-7. Top View of ROWPU With Operating, Equipment Removed (Army)

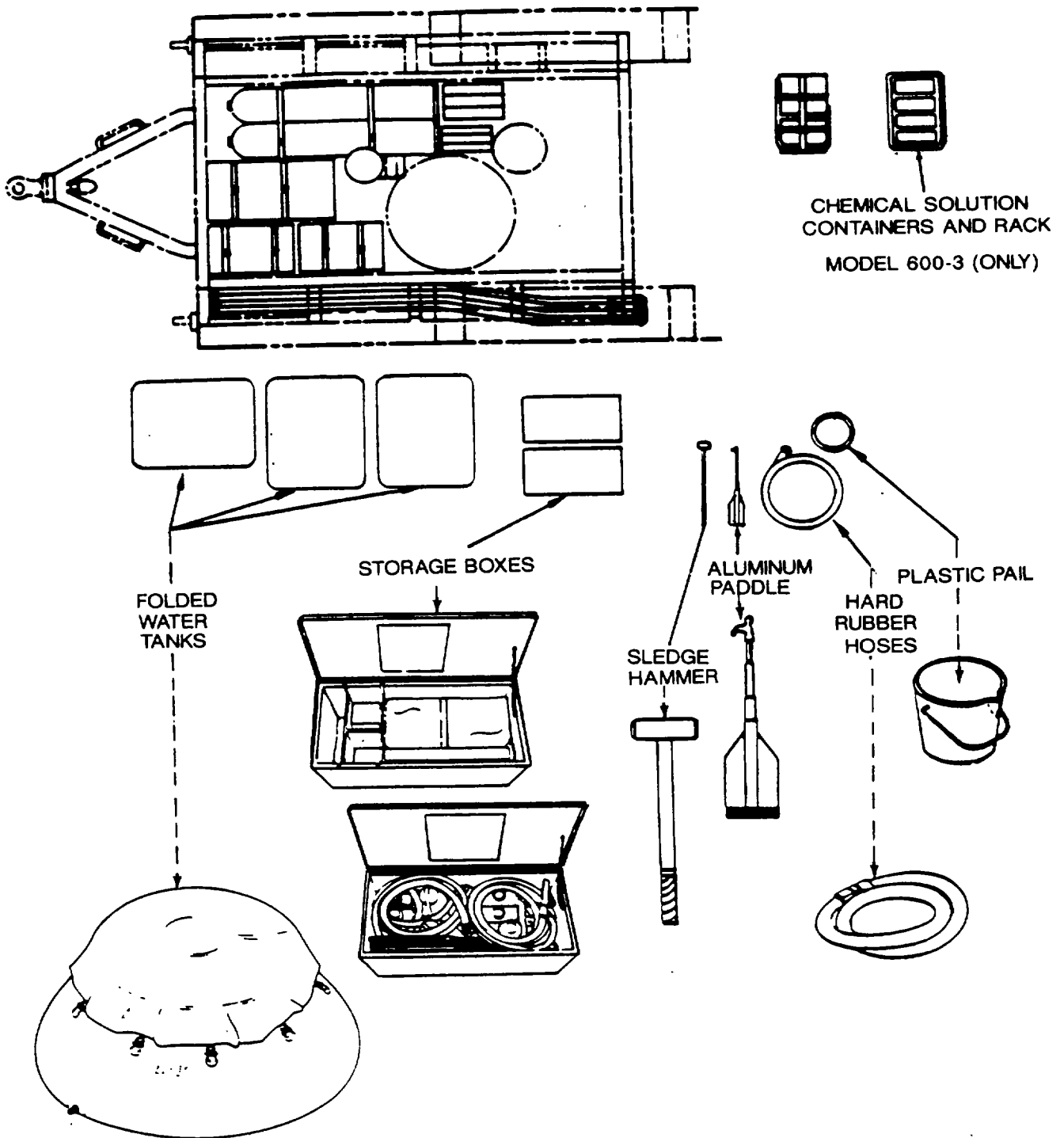

Figure 1-8. Top View of ROWPU With Operating Equipment Removed (MC)

LEGEND:

- |                           |                  |
|---------------------------|------------------|
| 1. Canvas Covers          | 6. Ground Rod    |
| 2. Cross Braces           | 7. Control Box   |
| 3. R. O. Pressure Vessels | 8. Generator Set |
| 4. R. O. Pump             | 9. Junction Box  |
| 5. Control Panel          |                  |

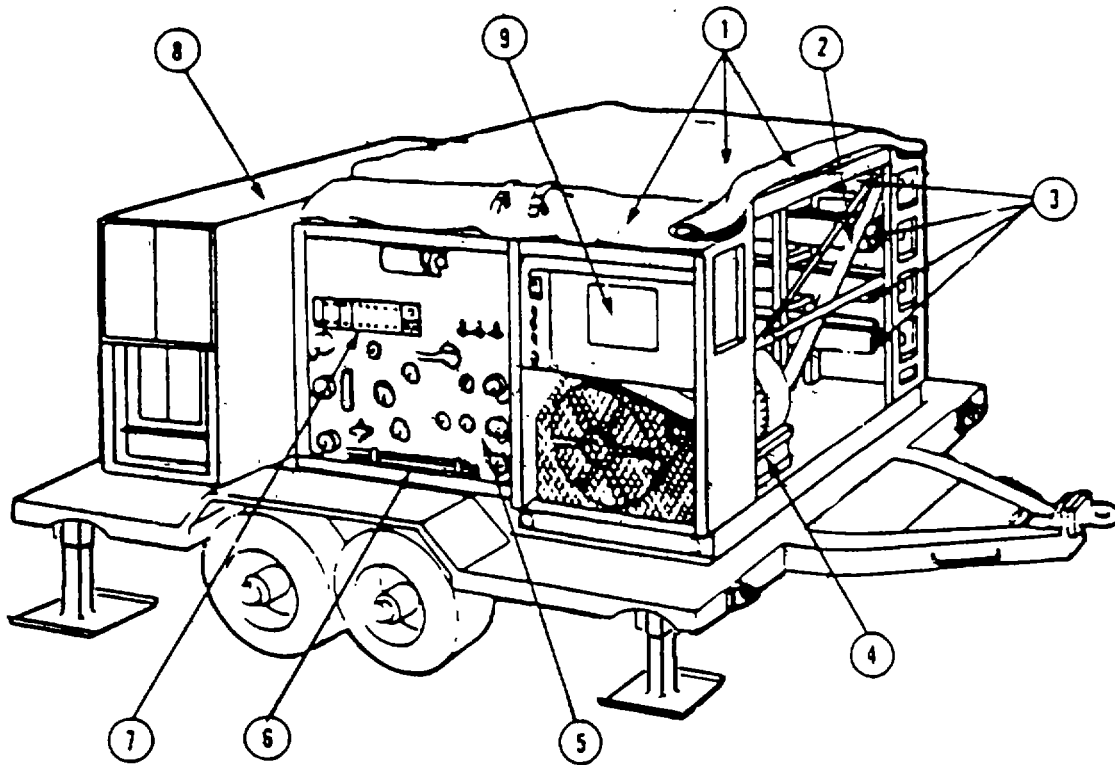

Figure 1-9. Control Panel Side Of ROWPU

NOTE

Illustration denotes Army Model No. 0996109001. MC Models are skid-mounted with no generator.

c. Fig. 1-9 identifies the following parts:

**CANVAS COVERS (1).** Protect unit from weather. Rolled up and strapped during normal operation.

**CROSS BRACES (2).** Give strength to ROWPU frame during shipment. Can be removed to get at equipment.

**R.O. PRESSURE VESSELS (3).** Four vessels which house eight reverse osmosis elements that reduce total dissolved solids from filtered water to produce drinking water.

**R.O. PUMP (4).** Applies high pressure to raw filtered water in R.O. vessels.

**CONTROL PANEL (5).** Panel with meters, switches, valves, and hose connections.

**GROUND ROD (6).** Driven into ground and attached to ROWPU to keep operators from getting electric shocks from power source or static electricity.

**CONTROL BOX (7).** Panel with switches to control all pumping and panel lighting.

**GENERATOR SET (8).** (Army) Provides electricity needed to operate ROWPU.

**JUNCTION BOX (9).** Contains circuit breakers, overload heaters, motor starters, etc.

- d. After you remove the equipment shown in fig. 1-10, 1-11, and 1-12, the inside of the ROWPU will be visible.

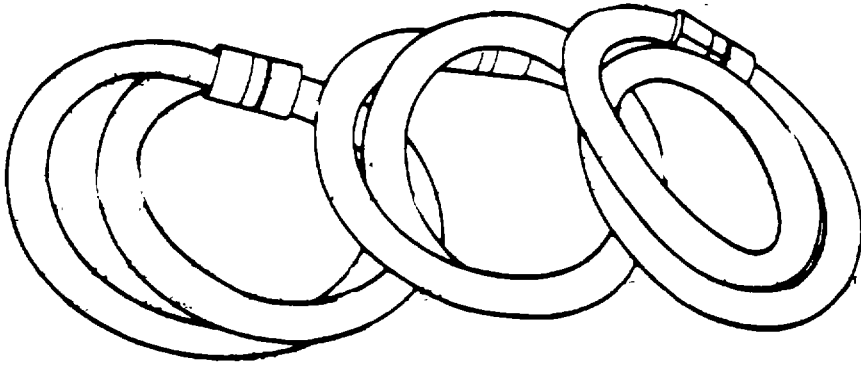

SUCTION HOSES HARD RUBBER

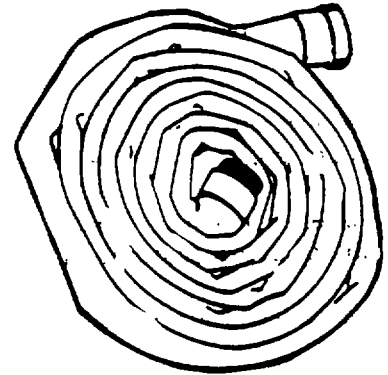

DISCHARGE HOSES (CANVAS)

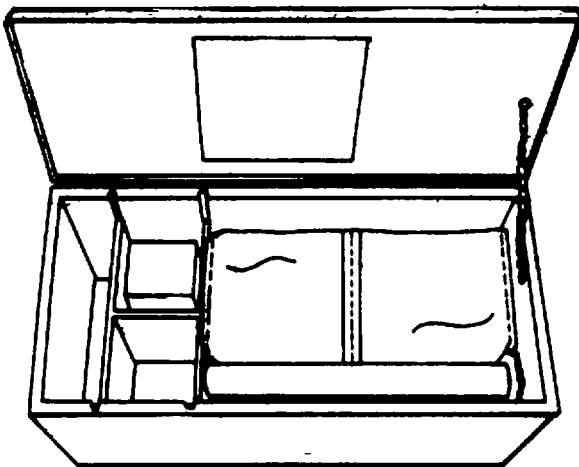

STORAGE BOX NO. 2

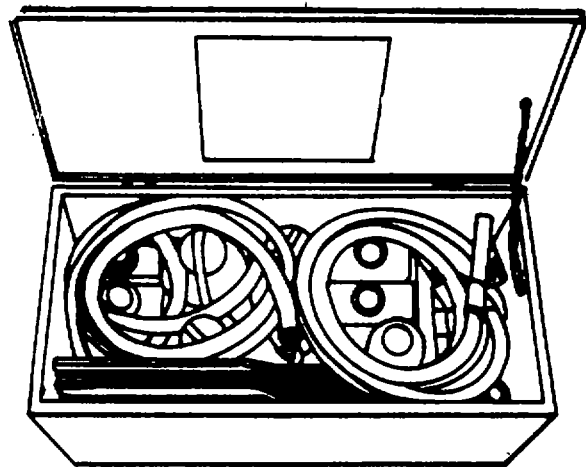

STORAGE BOX NO. 3

**NOTE**

Only two storage boxes exist. They are labeled Storage Boxes 2 and 3.

*Figure 1-10. Hoses and Storage Boxes*



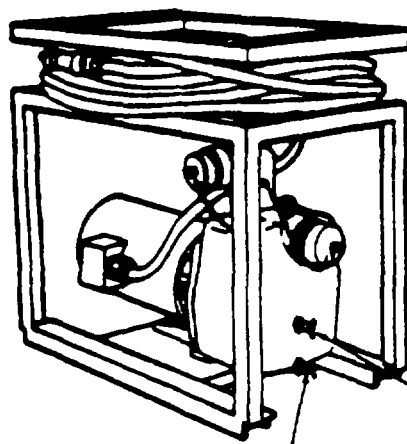

DRAIN VALVE

**RAW WATER PUMP ( 2 USED)**

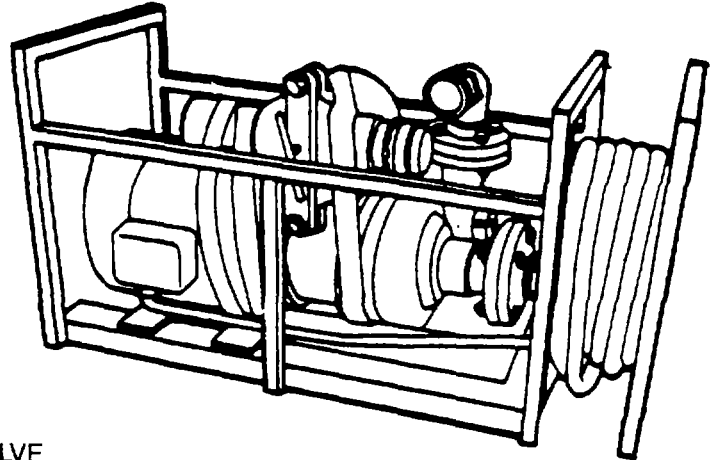

**BACKWASH PUMP**

*Figure 1-11. Raw Water And Backwash Pumps*

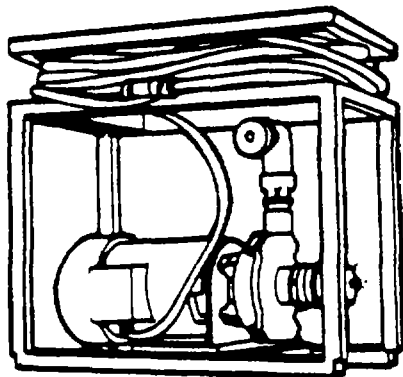

**DISTRIBUTION PUMP**

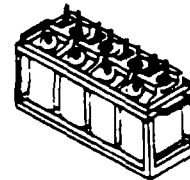

**CHEMICAL FEED CANS**

*Figure 1-12. Distribution Pump and Chemical Cans*

1. Multimedia Filter
2. R.O. Pressure Vessels
3. R.O. Pump
4. Control Panel
5. Cartridge Filter
6. Pulse Dampener
7. Booster Pump
8. Generator Platform (Army)
9. Prime/Run Valves
10. Chemical Feed Pump
11. Chemical Feed Containers

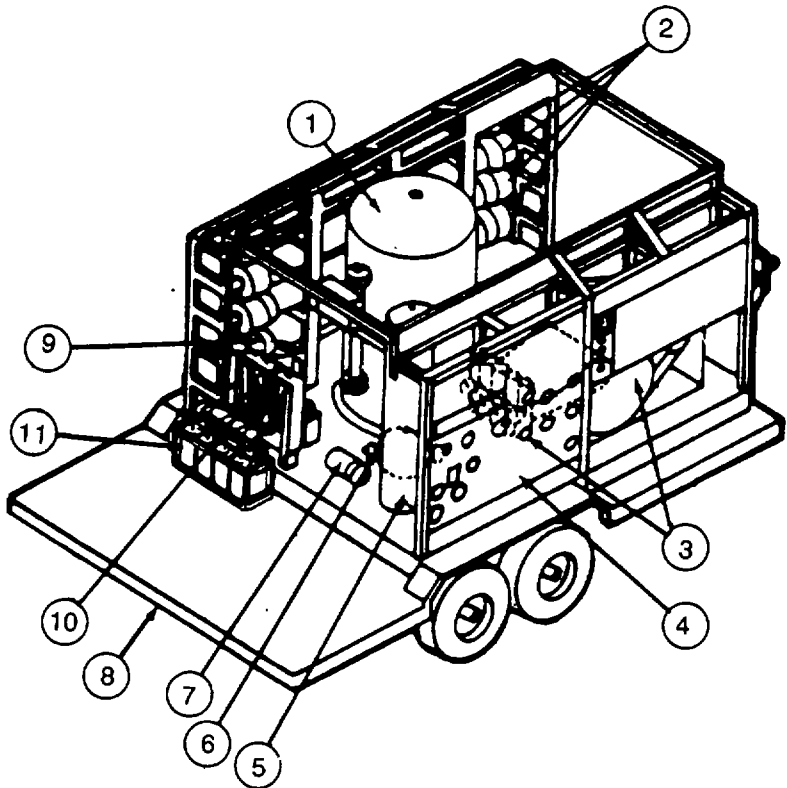

Figure 1-13. ROWPU - Generator Removed (Rear View)

**NOTE**

Illustration denotes Army ROWPU. Marine Corps unit is skid-mounted with no generator or platform.

e. Figure 1-13 identifies the following parts:

**MULTIMEDIA FILTER (1).** Provides first stages of removing unsafe matter from raw water.

**R.O. PRESSURE VESSELS (2).** Loaded with rolled, thin films (called elements). Here, osmosis is reversed by applying pressure to reduce dissolved solids from raw filtered water.

**R.O. PUMP (3).** Applies very high pressure to raw filtered water flowing through R.O. pressure vessels.

**CONTROL PANEL (4).** Panel on the control box assembly with meters, control valves, hose connections, and electrical switches.

**CARTRIDGE FILTER (5).** Provides more cleaning to water coming out of the multimedia filter.

**PULSE DAMPENER (6).** Located behind the cartridge filter, reduces shock (water pulses) caused by R.O. pump.

**BOOSTER PUMP (7).** Forces water from multimedia filter through the cartridge filter.

**GENERATOR PLATFORM (Army) (8).** A 30-kW generator set is mounted on this platform.

**PRIME/RUN VALVES (9).** Allows pumps to be primed in the PRIME position and dispenses chemicals in the RUN position.

**CHEMICAL FEED PUMP (10).** Pumps chemicals into water being processed.

**CHEMICAL FEED CONTAINERS (11).** Hold chemical solutions (polymer, sodium hex, citric acid, and chlorine) which are fed into chemical feed pump.

f. Figure 1-14 (Army) shows the location of the trailer's major components. The Marine Corps ROWPU is skid mounted, but the frame is the same as shown.

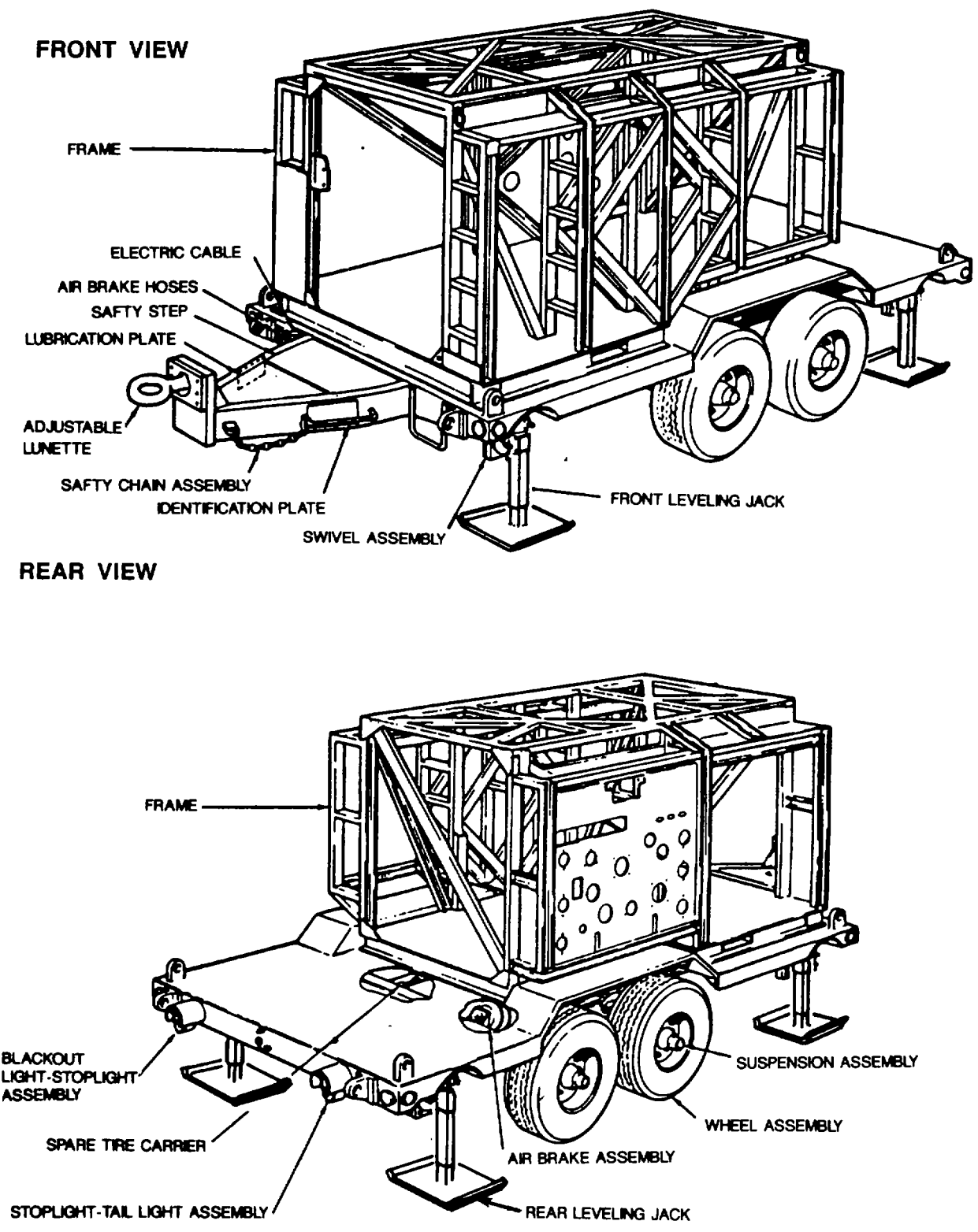

Figure 1-14. ROWPU Flatbed Trailer And Frame (Army Model No. 0996109001)

**1-7. EQUIPMENT DATA**

Dimensions and Weights (Trailer without ROWPU - Army Only)

Length.....	19.01 ft (5.8 m)
Width.....	8.00 ft (2.44 m)
Height (to top of the wheel cover).....	3.18 ft (0.97 m)
Weight.....	5595 lb (2540 kg)
Height to lunette.....	2.42 ft to 2.92 ft (0.74 m to 0.89 m)
Maximum towing speed.....	50 mph (80 kmh)
Tire pressure.....	75 psi (5.27 kg/sqcm)
Voltage.....	24 V dc

Power Requirements (Overall)

Power.....	22 kW
Voltage.....	120 V ac, 1-phase; 208-230/460 V ac, 3-phase
Frequency.....	60 Hertz
Current.....	104 amp (max)

ROWPU Size - Trailer Mounted (Army)

Length.....	19.1 ft (5.8 m)
Width.....	8.0 ft (2.44 m)
Height.....	8.08 ft (2.45 m)
Weight.....	16,975 lb (7700 kg)

ROWPU dimensions - Skid Mounted (MC)

Length.....	9.45 ft (2.86 m)
Width.....	6.91 ft (2.07 m)
Height.....	5.68 ft (1.7 m)
Weight.....	7,300 lb (3311.3 kg)

R.O. Pump Motor

Voltage.....	200 V ac, 3-phase
Current.....	56.3 amp
Horsepower.....	20
Frequency.....	60 Hertz
Revolutions Per Minute.....	1175
Duty Cycle.....	Continuous

R.O. Pump

Type.....	Positive displacement
Pumping Capacity.....	51 gpm (193 lpm) 980 psi (689,038 kq/sqm) head
Oil Capacity.....	2 US gallons (7.57 liters)
Drive.....	V-belt

Revolutions Per Minute..... 500 (maximum)

Backwash Pump Motor

Voltage..... 208230/460 V ac, 3-phase  
 Current..... 26.5-24/12 amp  
 Horsepower..... 10  
 Frequency..... 60 Hertz  
 Revolutions Per Minute..... 3450  
 Duty Cycle..... Continuous

Backwash Pump

Type..... Centrifugal  
 Capacity..... 120 gpm (454 lpm) 70 psig  
 (49,217 kg/sqm)  
 Drive..... Electric motor  
 Revolutions Per Minute..... 3500

Raw Water Pump Motor, 2 each

Voltage..... 220230/460 V ac, 3-phase  
 Current..... 5.8/2.9 amp  
 Horsepower..... 2  
 Frequency..... 60 Hertz  
 Revolutions Per Minute..... 3450  
 Duty Cycle..... Continuous

Raw Water Pump, 2 each

Type..... Centrifugal, self-priming  
 Capacity..... 30 gpm (114 lpm) 105 ft  
 (32 m) head  
 Drive..... Electric motor  
 Revolutions Per Minute..... 3500

Distribution and Booster Pump Motors

Voltage..... 208-230/460 V ac, 3-phase  
 Current..... 3.4-3.2/1.6 amp  
 Horsepower..... 1  
 Frequency..... 60 Hertz  
 Revolutions Per Minute..... 3450  
 Duty Cycle..... Continuous

Distribution and Booster Pumps

Type..... Centrifugal  
 Capacity..... 30 gpm (14 lpm) 50 ft  
 (15 m) head  
 Drive..... Electric motor  
 Revolutions Per Minute..... 3500

Chemical Feed Pump Motor

Voltage.....	115/230 V ac, 1-phase
Current.....	6.2/3.1 amp (Army) 4.8/2.4 amp (MC)
Horsepower.....	1/3
Frequency.....	60 Hertz
Revolutions Per Minute.....	1725
Duty Cycle.....	Continuous

Chemical Feed Pump

Capacity.....	3.17 gallons/hr (12 liters/hr)
Drive.....	Electric motor

Multimedia Filter

Flow Rate.....	6.5 gpm/sqft
Backwash Flow Rate.....	70 to 120 gpm (265 to 454 lpm)
Pressure Drop.....	5 psid (nominal) (3516 kg/sqm)

Cartridge Filter

Cartridge (8 cartridge tubes)	
Length.....	40 in (101.6 cm)
Flow Rate.....	35 gpm (132.5 lpm)
Pressure Drop.....	2 to 35 psid (1406 to 24,609 kg/sqm)

1-8. **PIPING IDENTIFICATION.** The ROWPU piping is identified according to function by the following colors:

Function:	Color:
Raw water	Black band
Backwash waste	Red band
Filtered water	Yellow band
Product water	Blue band
Brine discharge	Purple band
Brine Piping on R.O. pressure vessels	Purple band

**SECTION III. TECHNICAL PRINCIPLES OF OPERATION**

1-9. **WATER PROCESSING AND CHEMICALS.** The ROWPU removes suspended solids (called turbidity), chemicals, and solids held in solution (called dissolved solids), found in most fresh water and seawater sources, to a level fit for human consumption. This is done by filtering with the aid of the reverse osmosis process, and then additional purification using selected chemicals. Refer to figure 1-15 to follow the process described below.

a. First Stage of Filtration-Multimedia Filter. Before raw (untreated) water reaches the multimedia filter, polymer solution is added to it. Polymer collects suspended solids into groups large enough to be removed by the multimedia filter. This process is called coagulation. Water is then filtered through the multimedia filter.

b. Second Stage of Filtration-Cartridge Filter. The cartridge filter takes out finer suspended solids that pass through the multimedia filter.

c. Reverse Osmosis (R.O.) Elements. The first two stages of filtering do not remove dissolved solids from the water. The R.O. elements, through the R.O. process, remove dissolved minerals and any suspended solids that may have passed through the filters.

d. Chlorine Disinfection. As the water leaves the ROWPU, chlorine is added to kill any bacteria present in the product water. At this point, the product water is stored for human consumption.

**1-10. REVERSE OSMOSIS (R.O.) PROCESS.** Reverse osmosis is the process by which purified water is separated from the available seawater or brackish water source. Pressure is applied to the salt water side of a semipermeable membrane, and purified water diffuses through the membrane to the freshwater side. The 600 GPH ROWPU is arranged so that pre-filtered water is pumped under pressure across the semi-permeable membranes, called R.O. membranes. The R.O. membranes separate this water stream into a product water stream and a brine concentrate stream, both of which continuously flow away from the membranes.

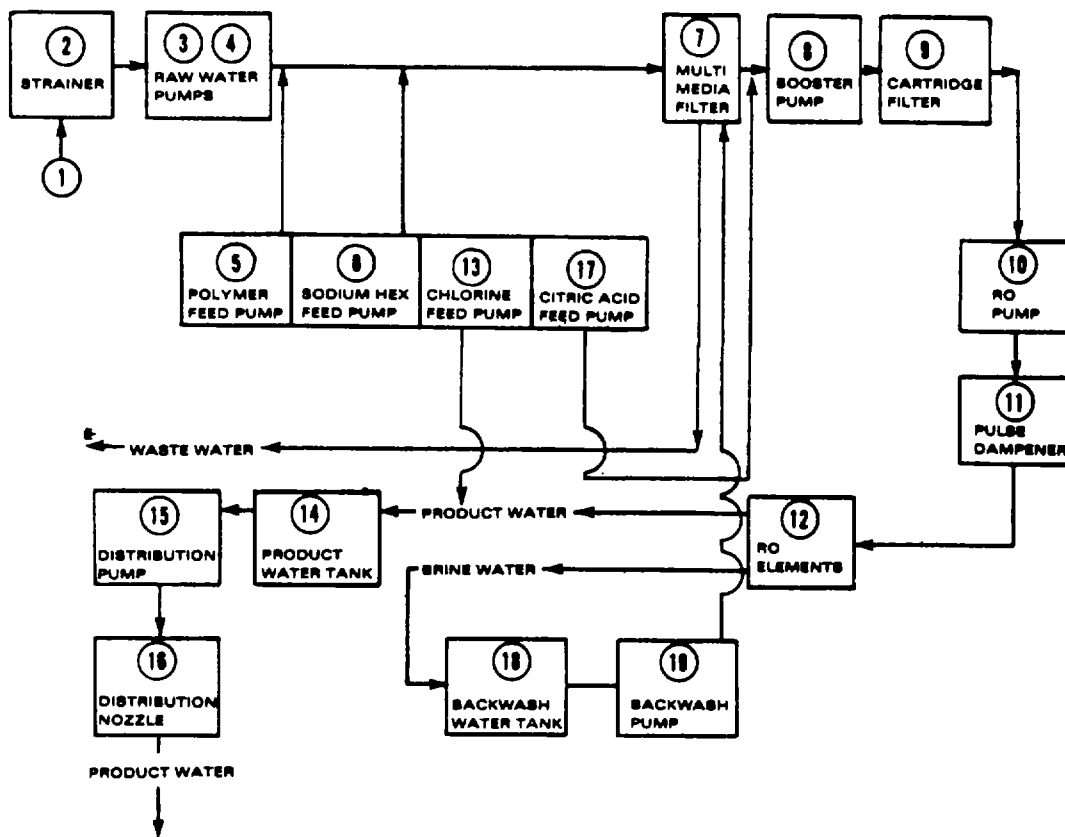

Figure 1-15. Water Processing Block Diagram



**WARNING**

Source water must be free of chlorine.

**RAW WATER SOURCE (1).** Any place you can get water.

**STRAINER (2).** A screen on the end of a suction hose to keep leaves, plants, stones, fish, and dirt out of the pumps and filters of the ROWPU.

**RAW WATER PUMPS (3) (4).** Draw water from source and pump it into ROWPU under pressure.

**POLYMER FEED PUMP (5).** Adds polymer (polyelectrolyte) solution to raw water to collect small pieces of floating solid matter into groups large enough to be removed by the multimedia filters.

**SODIUM HEX FEED PUMP (6).** Feeds diluted sodium hex (sodium hexametaphosphate) to raw water to prevent scaling.

**MULTIMEDIA FILTER (7).** First stage of filtering for raw water.

**BOOSTER PUMP (8).** Forces filtered water from multimedia filter through the cartridge filter.

**CARTRIDGE FILTER (9).** Perform additional filtering of very small particles from water coming out of multimedia filter.

**R.O. PUMP (10).** Forces filtered water under high pressure through R.O. elements.

**PULSE DAMPENER (11).** A ball-shaped metal tank used to reduce pulses in water flow caused by pistons of R.O. pump.

**R.O. ELEMENTS (12).** Rolls of thin films that separate dissolved solids from the raw filtered water.

**CHLORINE FEED PUMP (13).** Adds chlorine to product water to kill bacteria to make water in tanks drinkable.

**PRODUCT WATER TANKS (14).** Storage containers for product (drinkable) water.

**DISTRIBUTION PUMP (15).** Pumps drinkable water from product water tank into the water-carrying vehicle or container.

**DISTRIBUTION NOZZLE (16).** Used for filling user's container with drinkable water coming from product water tanks by way of the distribution pump.

**CITRIC ACID FEED PUMP (17).** Adds diluted citric acid (tricarboxylic) to filtered water to maintain the desired pH for the R.O. process to take place.

**BACKWASH WATER TANK (18).** Stores brine water used for flushing the multimedia filter.

**BACKWASH PUMP (19).** Pumps brine water backwards from backwash tank through the multimedia filter to flush out accumulated dirt. Recirculates citric acid solution through the R.O. elements to clean them.

## CHAPTER 2

### OPERATING INSTRUCTIONS

#### SECTION I. DESCRIPTION AND USE OF OPERATOR'S CONTROLS AND INDICATORS

**2-1. CONTROLS AND INDICATORS (TRAILER).** (Army) The only indicators on the flatbed trailer are the stop lights, tail lights, and the blackout light. These lights are powered and controlled from the towing vehicle through a trailer cable. The plug on the cable (fig. 2-1) and the receptacle makes the system operational. The two air hoses connect to the towing vehicle brake system with glad-hand connectors (fig. 2-2). When the trailer is not connected to the towing vehicle, the connectors are stowed on dummy couplers on the trailer to prevent damage and contamination.

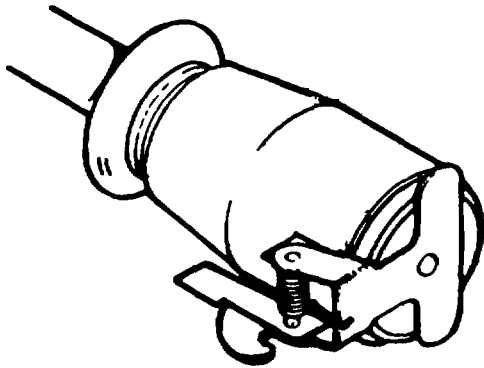

Figure 2-1. Electrical Plug

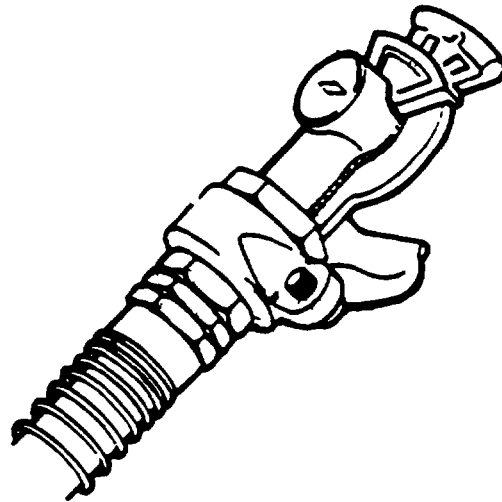

Figure 2-2. Air Hose Glad-Hand Connectors

#### **CAUTION**

Do not attempt to move trailer without releasing airbrakes; this requires 90-130 psi air pressure applied to air hoses.

**2-2. BRAKE SYSTEM.** (Army) The service brakes are air-actuated, and the controls are in and part of the towing vehicle. When the two air hoses from the trailer are connected to the connectors on the towing vehicle, the service brake system and the brake pedal on the towing vehicle automatically operate the trailer brakes. An air tank mounted under the trailer frame serves as a reservoir for the operation of the service brake system when the air hoses are disconnected from the towing vehicle. Disconnecting the air hoses causes the service brakes to engage automatically, thus serving as parking brakes for the trailer. Should the air supply from both the towing vehicle and the trailer reservoir be interrupted, a compression spring immediately locks the brakes. See fig. 2-82 for procedure for resetting locked spring brake.

### **CAUTION**

The leveling jacks must be in the stowed position (horizontal position) when towing or shipping the ROWPU by truck or rail.

**2-3. LEVELING JACKS.** (Army) The leveling jacks are secured by a swivel assembly to a movable support bracket located under the deck of the trailer at each corner. The swivel assembly contains a spring-loaded mounting assembly (Model No. 0996109001 ) which can lock the assembly in either the vertical or the horizontal position. In the vertical position, the jacks are used to level the trailer by raising or lowering the trailer corners as necessary. In the horizontal position the jacks are stowed. The front jacks, when locked in the vertical position, can also be used to assist in uncoupling the trailer from the towing vehicle. Turning the crank counterclockwise raises the jackpad; turning the crank clockwise lowers the jackpad.

**2-4. SPARE WHEEL AND TIRE CARRIER ASSEMBLY.** (Army) The spare wheel and tire carrier has a manually operated, cable-driven winch mounted on the frame structure at the rear end and underside of the trailer. The two wheel lug nuts installed on the carrier are the same as those on the towing vehicle, thereby enabling the use of the towing vehicle's lug wrench for removal or replacement of the spare wheel tire assembly.

**2-4.1. WATER METER.** The water meter is located on the floor of the frame directly behind the booster pump as shown in fig. 2-3. This meter is used to indicate the total number of gallons, in tenths of a gallon, of product water the unit has produced. The number of gallons is read directly from the numerals in the small window and the tenths of gallons from the position of the needle on the dial face.

**2-5. CONTROL PANEL.** The control panel consists of various gages, valves, lights, switches, and hose connections as shown in fig. 2-4, sheet 1. Their functions are described in Table 2-1 (Keys 1 through 23 and 53).

**2-6. CONTROL BOX.** The control box consists of the pump control switches and indicator lamps as shown in fig. 2-4, sheet 2. Their functions are described in Table 2-1 (Keys 24 through 43).

**2-7. CIRCUIT BREAKER PANEL.** The circuit breaker panel is located in the junction box and consists of circuit breakers for the pumps, utility outlets and backwash timer as shown in fig. 2-4, sheet 3. Their functions are described in Table 2-1 (Keys 44 through 52).

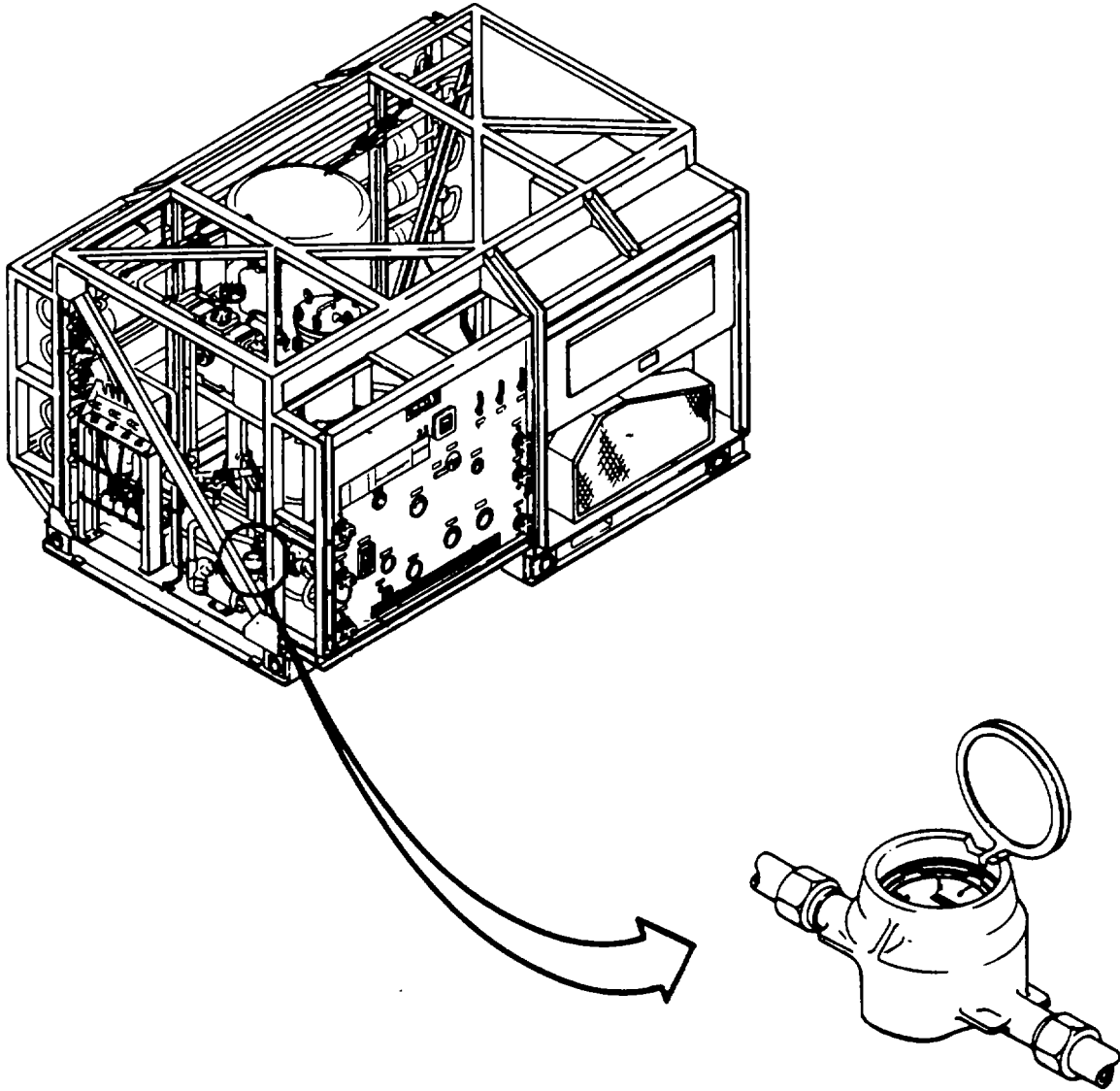
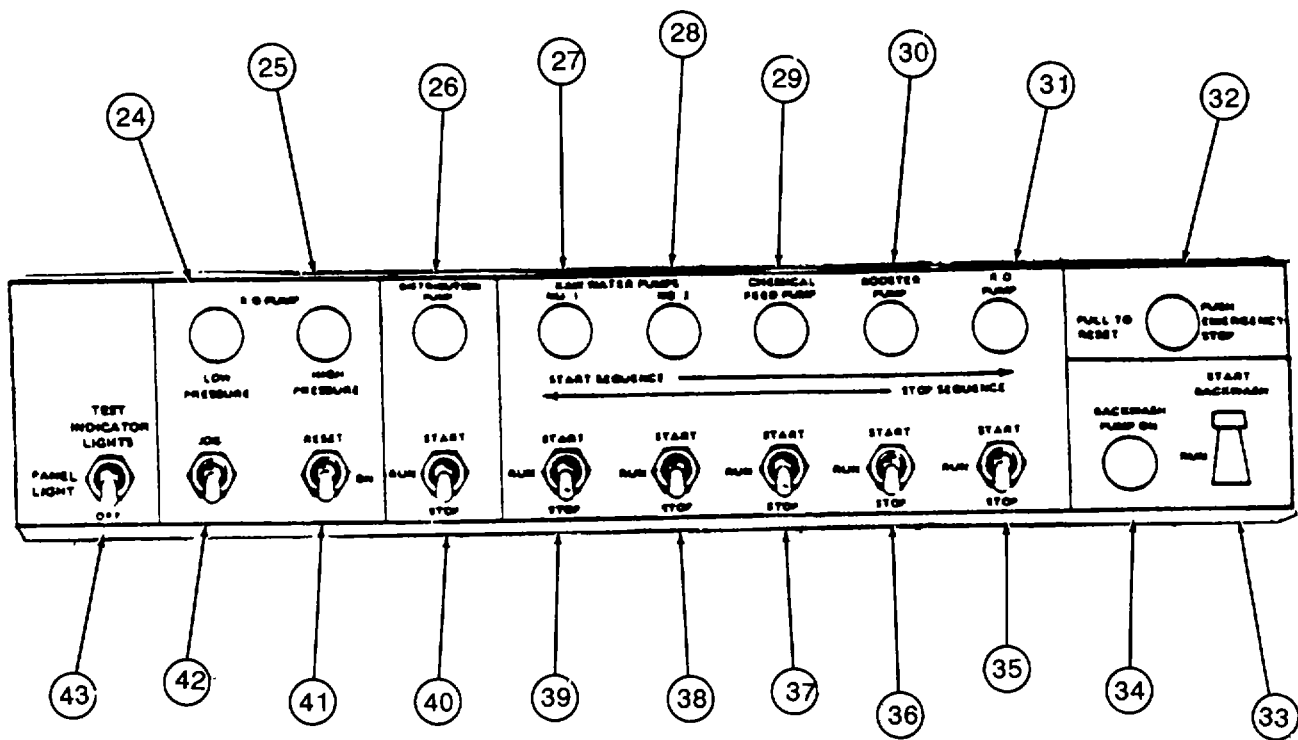

Figure 2-3. Water Meter





CONTROL BOX

Figure 2-4. Controls And Indicators: Control Panel (Sheet 2 of 3)

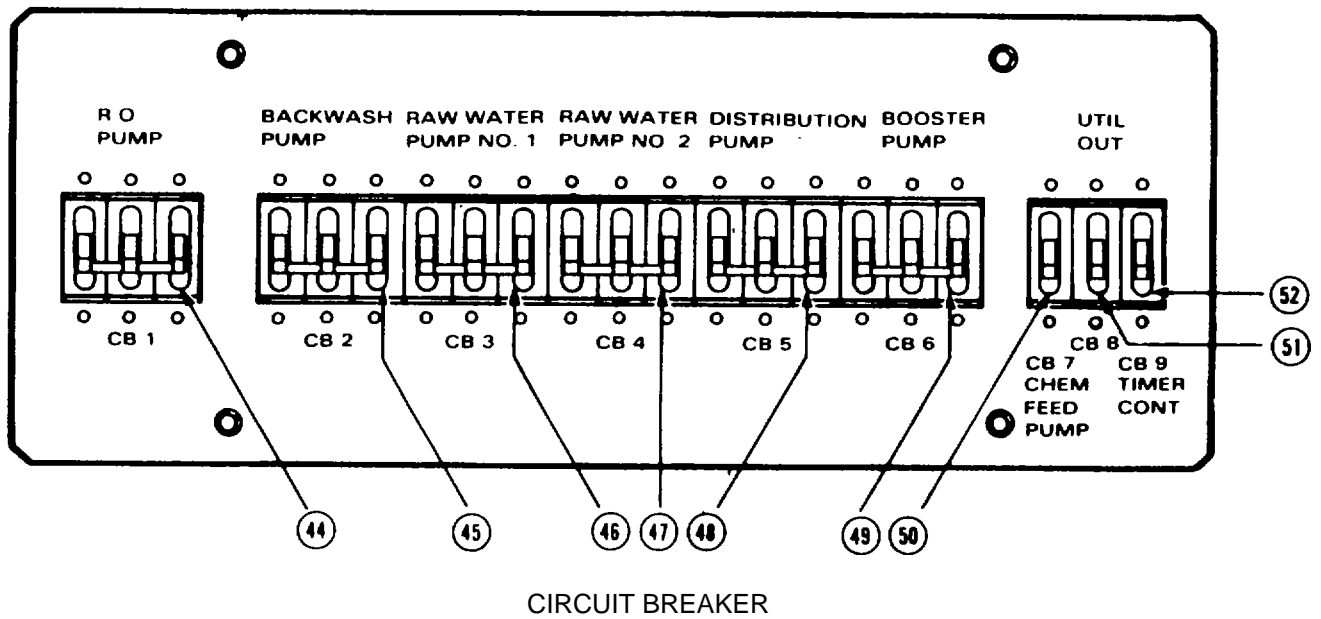

Figure 2-4. Controls And Indicators: Control Panel (Sheet 3 of 3)

Table 2-1. Water Processing Controls and Indicators

Key	Control or Indicator	Function
1	Control Box Assembly	Indicator lamps; switches to start, operate and stop (including EMERGENCY STOP) all pumps. (See fig. 2-4 sh 2 keys 24 through 43).
2	Panel Light	Provides light for inside of the ROWPU and for the control panel. It is mounted on a movable bracket that can be pulled forward to provide more light on the control panel.
3	Vent Cartridge Filter Valve	Relieves air from cartridge filter.
4	Vent Pulse Dampener Valve	Relieves air from pulse dampener.
5	Vent Multimedia Filter Valve	Relieves air from multimedia filter.
6	Backwash Valve	Backwash valve has two positions: NORMAL and BACK-WASH. In NORMAL, the valve closes the backwash inlet and allows raw water to flow through the ROWPU. In BACKWASH, the raw water inlet is closed and water is allowed to flow through the backwash inlet. After back-washing, the valve should be returned to the NORMAL position.
7	Multimedia Filter Gage	Indicates differential pressure across the multimedia filter.
8	Waste	Connection for dirty brine used to backwash the multimedia filter.
9	R.O. Vessels Gage	Indicates differential pressure across the R.O. vessels.
10	Raw Water Flow	Measures in gallons per minute the amount of water drawn in by raw water pumps and fed into ROWPU.
11	Backwash Water	Connection for backwash hose.
12	Raw Water	Connection for hose from raw water pumps.
13	Ground Rod	Used to ground ROWPU. Protects personnel from electrical shock.
14	Backwash Water Flow Gage	Measures amount of water flowing through multimedia filter during backwash cycle.
15	R.O. Pressure P.S.I. Gage	Shows discharge pressure of the R.O. pump in pounds per square inch (psi). Gage reading depends on setting of REGULATE PRODUCT FLOW valve.
16	Brine Flow meter	Measures amount of brine flow from the ROWPU in gallons per minute.
17	Regulate Product Flow Valve	Closes the outlet of the R.O. vessels. Controls the rate of flow of the product water. Regulates output pressure of the R.O. pump.
		2-7



Table 2-1. Water Processing Controls and Indicators (Continued)

Key	Control or Indicator	Function
18	Brine	Connection for brine water hose from the ROWPU to brine tank.
19	Vent Vessels	Diverts water from R.O. vessels to allow multimedia filter to stabilize. Also inputs R.O. element cleaning solution.
20	Product Water Flow	Shows the number of gallons per minute of drinking water put out by the ROWPU.
21	Cartridge Filter Gage	Measures pressure drop across cartridge filter.
22	Product Water	<p>Connection for drinking water from ROWPU to product water tank.</p> <p style="text-align: center;"><b><u>CAUTION</u></b></p> <p>Element Cleaning switch must be OFF when backwashing the multimedia filter. Operating R.O. element cleaning during backwashing can cause damage to the R.O. elements.</p>
23	R.O. Element Cleaning Switch	<p>Used to operate backwash pump during cleaning of R.O. elements (switch must be OFF at all other times).</p> <p style="text-align: center;"><b><u>NOTE</u></b></p> <p>See fig. 2-4 sh 2 for illustration of items 24 through 43.</p>
24	R.O. Pump Low Pressure	Blue lamp that comes on when R.O. pump suction pressure Indicator Lamp drops below 10 psi. This lamp also indicates that R.O. pump should have shut off.
25	R.O. Pump High Pressure	Blue lamp that comes on when R.O. pump discharges Indicator Lamp pressure is higher than 1250 psi. This lamp also indicates that R.O. pump should have shut off.
26	Distribution Pump Indicator Lamp	Blue lamp comes on when distribution pump motor is running normally.
27	Raw Water Pump No. 1 Indicator Lamp	Blue lamp comes on when raw water pump No. 1 motor is running normally.
28	Raw Water Pump No. 2 Indicator Lamp	Blue lamp comes on when raw water pump No. 2 motor is running normally.
29	Chemical Feed Pump Indicator Lamp	Blue lamp comes on when chemical feed pump motor is running normally.
30	Booster Pump Indicator Lamp	Blue lamp comes on when booster pump motor is running normally.
		<b>2-8</b>

Table 2-1. Water Processing Controls and Indicators (Continued)

Key	Control or Indicator	Function
31 normally.	R.O. Pump Indicator Lamp	<p>Blue lamp comes on when R.O. pump motor is running</p> <p style="text-align: center;"><b><u>CAUTION</u></b></p> <p>The EMERGENCY STOP switch should not be used to shut off the ROWPU except in emergency conditions. To do so can cause damage to the equipment.</p>
32	Push EMERGENCY STOP Switch	When pushed in, this switch shuts off power to all pump motors.
33	Start Backwash Switch	Toggle switch used to start the backwash pump motor.
34	Backwash Pump On Indicator Lamp	Blue lamp comes on when backwash pump motor is running normally.
35	R.O. Pump Start Switch	Toggle switch used to start, run, and stop the R.O. pump motor.
36	Booster Pump Start Switch	Toggle switch used to start, run, and stop the booster pump motor.
37	Chemical Feed Pump Start Switch	Toggle switch used to start, run, and stop the chemical feed pump motor.
38	Raw Water Pump No. 2 Start Switch	Toggle switch used to start, run, and stop the raw water pump No. 2 motor.
39	Raw Water Pump No. 1 Start Switch	Toggle switch used to start, run, and stop the raw water pump No. 1 motor.
40	Distribution Pump Start Switch	Toggle switch used to start, run, and stop the distribution pump motor.
41	R.O. Pump Reset Switch	Toggle switch that resets the high- or low-pressure switch after it shuts off the R.O. pump. If the malfunction has been corrected, this switch will turn off the LOW PRESSURE or HIGH PRESSURE indicator lamp.
42	R.O. Pump Jog Switch	Toggle switch that can be used to run the R.O. pump 3 to 5 seconds.
43	Panel Light Switch	Toggle switch used to turn the panel light on and off. The toggle switch is also used to test panel indicator lights.

Table 2-1. Water Processing Controls and Indicators (Continued)

Key	Control or Indicator	Function
<b>NOTE</b>		
Items 44 through 52 are circuit breakers located in the junction box, which provides electrical power for all electrical components. See fig. 2-4, sheet 3.		
44	R.O. Pump CB 1	Automatically shuts off power to R.O. pump motor if there is an electrical malfunction in the circuit.
45	Backwash Pump CB 2	Automatically shuts off power to the backwash pump motor if there is an electrical malfunction in the circuit.
46	Raw Water Pump No. 1 CB 3	Automatically shuts off power to raw water pump No. 1 motor if there is an electrical malfunction in the circuit.
47	Raw Water Pump No. 2 CB 4	Automatically shuts off power to raw water pump No. 2 motor if there is an electrical malfunction in the circuit.
48	Distribution Pump CB 5	Automatically shuts off power to distribution pump motor if there is an electrical malfunction in the circuit.
49	Booster Pump CB 6	Automatically shuts off power to booster pump motor if there is an electrical malfunction in the circuit.
50	CB 7 Chem Feed Pump	Automatically shuts off power to the chemical feed pump motor if there is an electrical malfunction in the circuit.
51	UTIL Out CB 8	Automatically shuts off power to the utility outlets if there is an electrical malfunction in the circuit.
52	CB 9 Timer Cont	Automatically shuts off power to the backwash timer and backwash pump motor if there is an electrical malfunction in the timer circuit.
53	In-Line TDS Monitor	Used to continually monitor quality of product water.

**2-8. VENT VESSELS VALVE.** The vent vessel valve is located behind the control panel. Closing vent vessels valve allows approximately 200 - 300 psi of filtered water pressure to build in R.O. vessels.

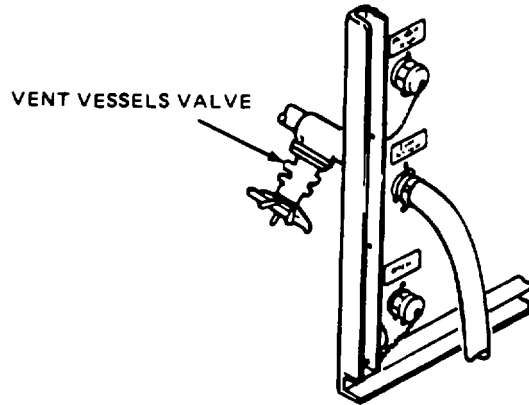

Figure 2-5. Vent Vessels Valve

**2-9. VENT PRODUCT WATER VALVE.** The vent product water valve is located to the right of the top R.O. vessel. It allows air to escape from product water line. It is located on top of product water manifold.

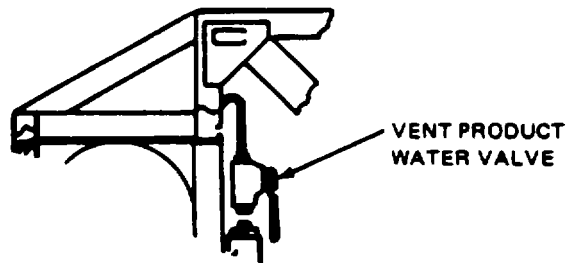

Figure 2-6. Vent Product Water Valve

**2-10. CHEMICAL FEED PUMP CONTROLS.** Knobs are located as shown and are used to control the flow of each chemical.

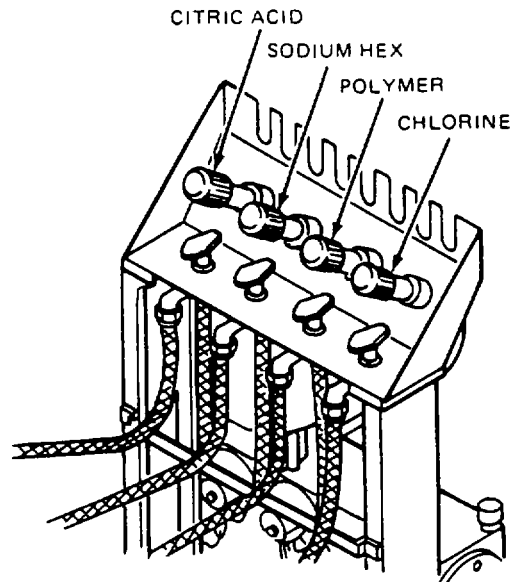

Figure 2-7. Chemical Feed Pump Controls

**2-11. GATE VALVES.** Two gate valves are used. One is installed between the brine tank and backwash pump, the other between the product water tanks;

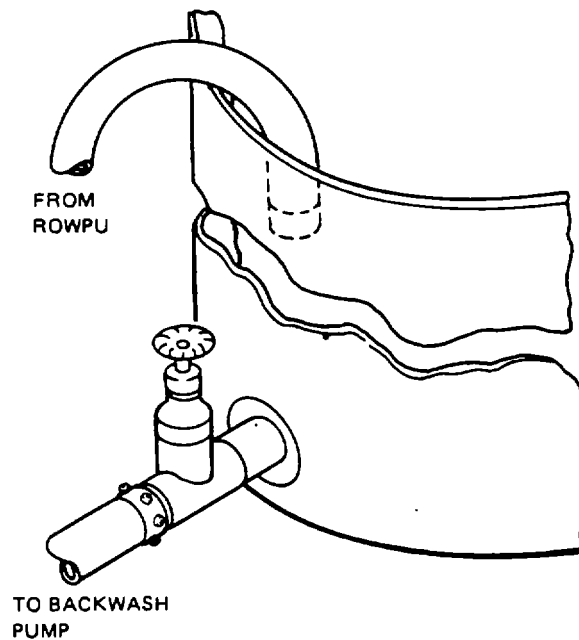

Figure 2-8. Gate Valves

**2-12. DRAIN VALVES.** Seven drain valves are located at the left front of ROWPU. They are used to draw samples at various stages of purification and to drain water from unit before moving.

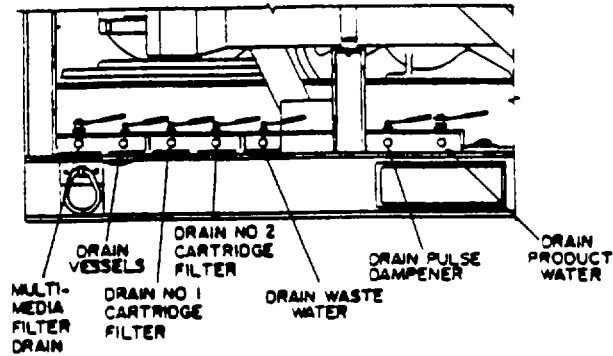

Figure 2-9. Drain Valves

**2-13. CHEMICAL FEED PUMP VALVES.** Valves have two positions: PRIME and RUN. PRIME is for priming chemical feed pumps, and RUN for adding chemicals.

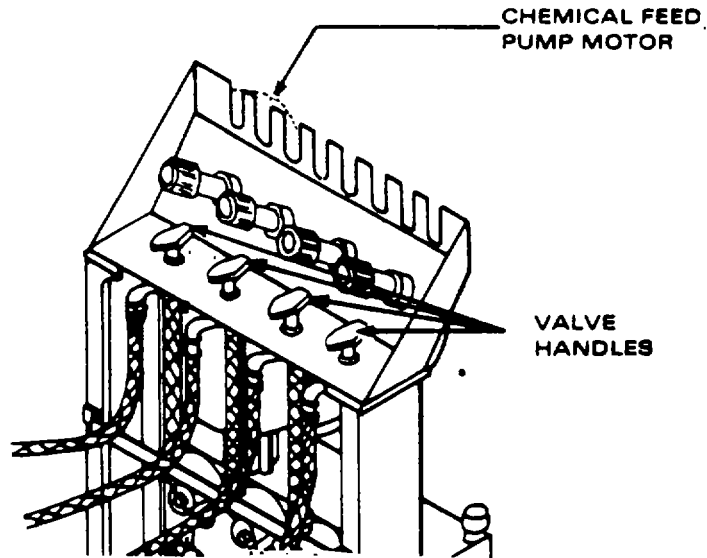

Figure 2-10. Chemical Feed Pump Valves

**2-14. TOTAL DISSOLVED SOLIDS (TDS) METER (PORTABLE).** The portable TDS meter is used to measure total dissolved solids in raw and product water.

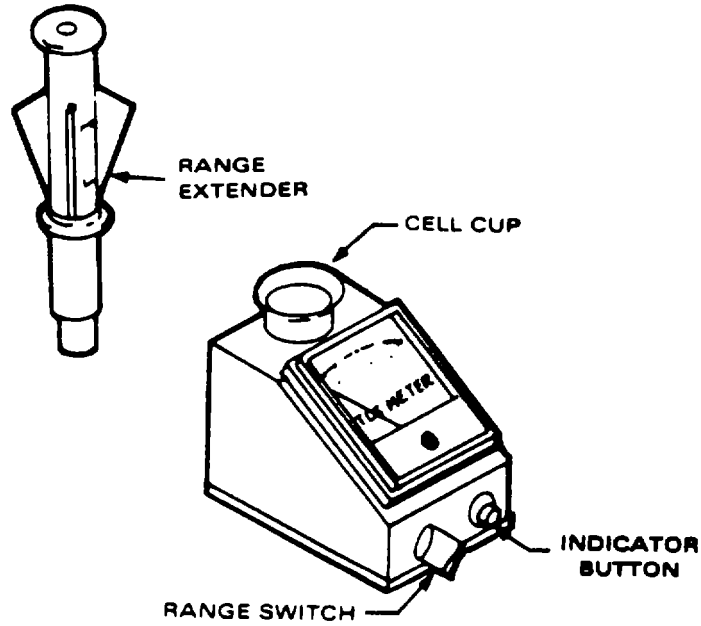

Figure 2-11. Total Dissolved Solids (TDS) Meter (Portable)

**2-15. TOTAL DISSOLVED SOLIDS (TDS) METER (In-Line).** The TDS meter is used to measure total dissolved solids in raw and product water.

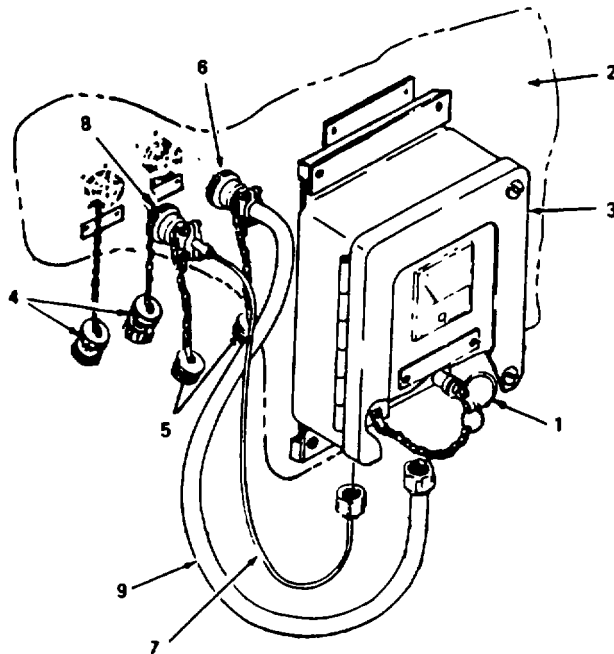

Figure 2-12. Total Dissolved Solids (TDS) Meter (In-Line)

**a. Installation.**

- (1) Remove pin (1) from panel face (2).
- (2) Position top of meter (3) Inside of upper bracket on panel face.
- (3) Slide meter to left and engage bottom of meter In slot of lower bracket.
- (4) Continue to slide meter to left until meter Is fully engaged. Secure meter by positioning pin (1) through hole in bottom of meter and hole In panel face.
- (5) Remove protective cover (4) from terminal marked TDS MONITOR POWER and TDS MONITOR SENSOR located on panel face.
- (6) Remove protective covers (5) from cable (9) and attach connector (6) to terminal marked TDS MONITOR POWER.
- (7) Remove protective covers (5) from cable (7) and attach connector (8) to terminal marked TDS MONITOR SENSOR.

**b. Removal.**

- (1) Disconnect cable (9) from terminal marked TDS MONITOR POWER and attach protective cover (5) to connector (6).
- (2) Disconnect cable (7) from terminal marked TDS MONITOR SENSOR and attach protective cover (5) to connector (8).
- (3) Remove pin (1) from bottom of panel face and slide meter (3) to right until bottom of meter clears bottom of bracket.
- (4) Lift meter (3) from panel face.
- (5) Attach protective covers (4) to two terminal connectors.
- (6) Install pin (1) to panel face.



2-16. **TURBIDITY TUBE.** The turbidity tube is used to see how clear the filtered water is.

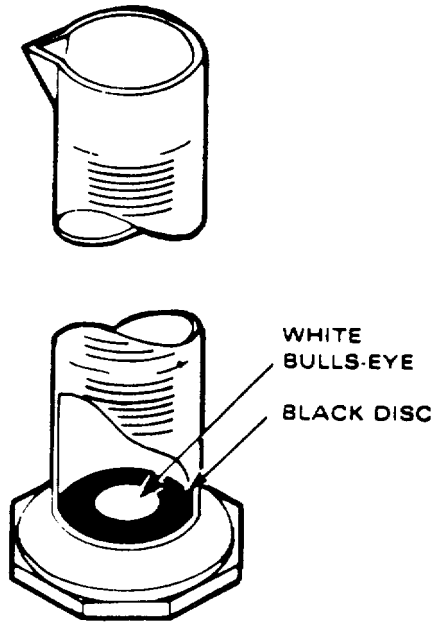

Figure 2-13. Turbidity Tube

2-17. **COLOR COMPARATOR KIT.** The color comparator kit is used to measure the amounts of chlorine in the product water and to determine its pH.

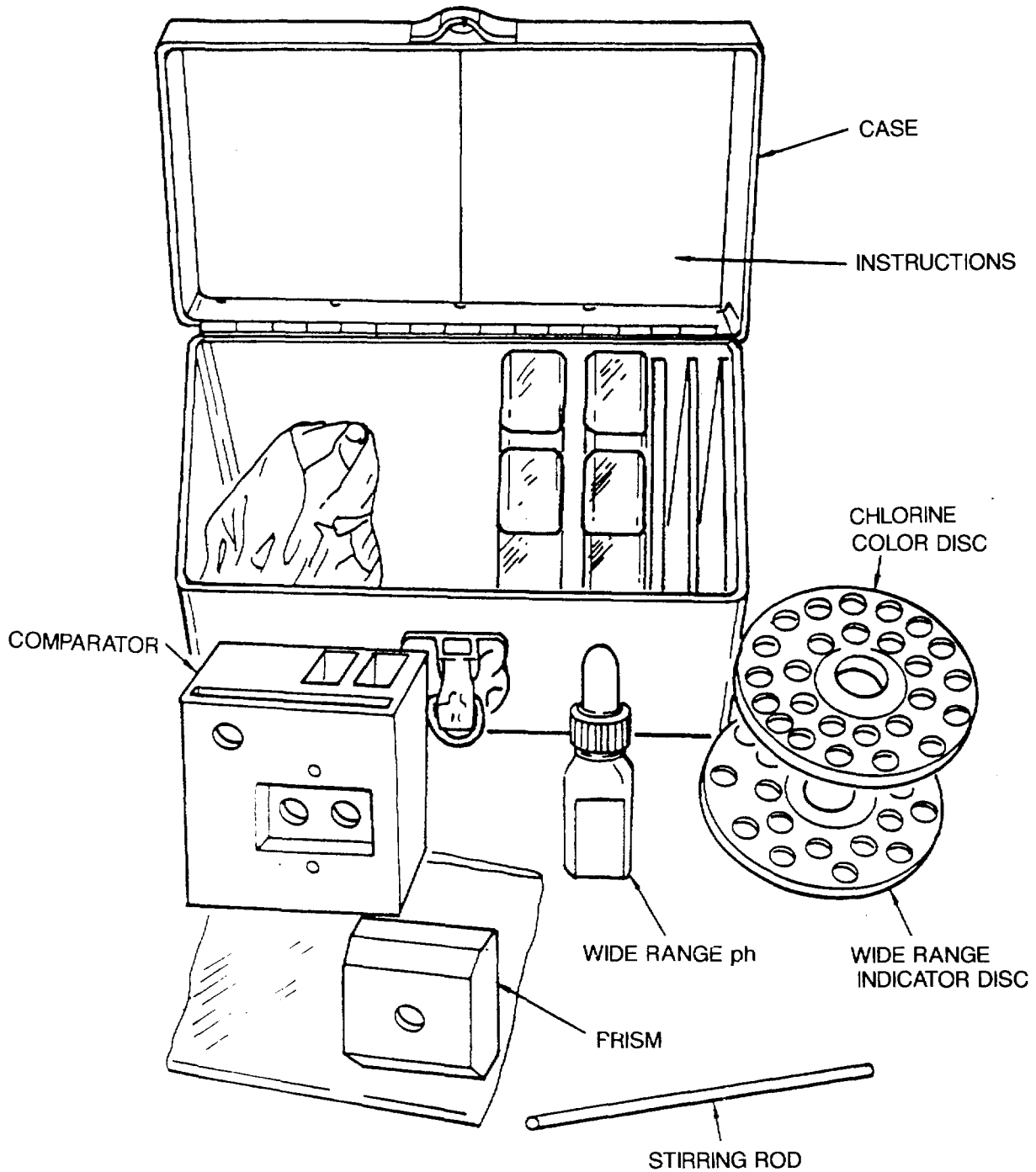

Figure 2-14. Color Comparator Kit

**2-18. BACKWASH TIMER.** The backwash timer automatically starts and ends the different stages of backwash cycle.

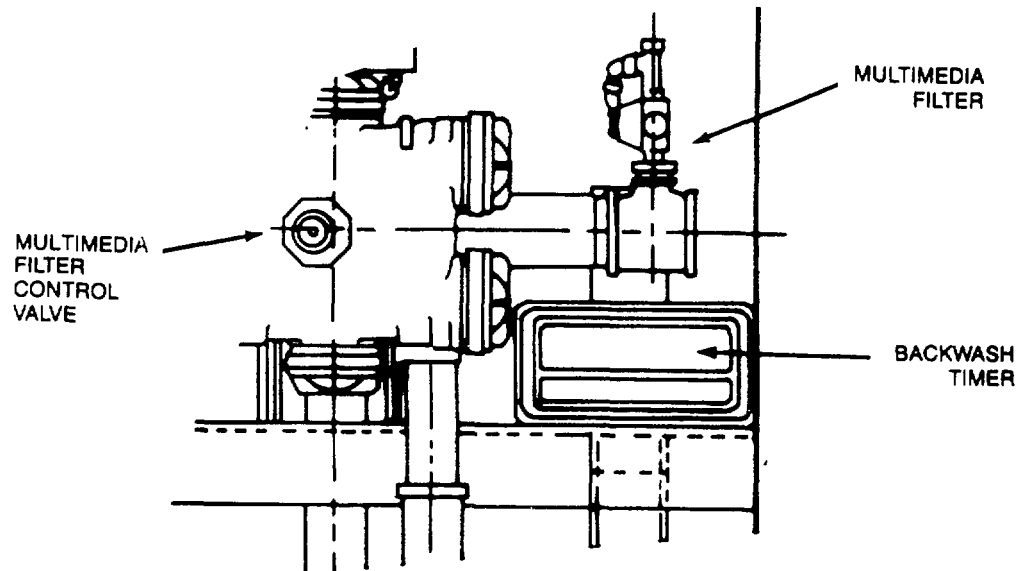

Figure 2-15. Backwash Timer

**NOTE**

**(SOLID STATE TIMER)**

Backwashing can be accomplished at any time without any preset conditions.

**SECTION II. PREVENTIVE MAINTENANCE CHECKS AND SERVICES (PMCS)**

**2-19. GENERAL.**

a. Before You Operate. Always keep in mind each CAUTION and each WARNING. Perform "BEFORE OPERATION" (B) PMCS shown in tables 2-2 and 2-3.

b. While You Operate. For your own safety and for protection of the equipment pay attention to each CAUTION and WARNING. Perform "DURING OPERATION" (D) PMCS shown in tables 2-2 and 2-3.

c. After You Operate. Perform "AFTER OPERATION" (A) PMCS shown in tables 2-2 and 2-3.

d. If The ROWPU Fails To Operate. Troubleshoot with proper equipment. Report difficulties, using the proper forms. Army users see DA PAM 738-750; Marine Corps users refer to TM 4700-15/1.

**2-20. PMCS PROCEDURES.**

a. Performing PMCS, tables 2-2 and 2-3, will help keep the ROWPU from breaking down.

b. It is necessary to know what the numbers and letters on the table mean.

(1) Item number - the order in which ROWPU is checked. It will also be the item number to record results of PMCS in the "TM Number" column on DA Form 2404, Equipment Inspection and Maintenance Worksheet. Marine Corps personnel use form NAVMC 10524.

(2) Interval - when you make your checks:

B "BEFORE OPERATION"  
D "DURING OPERATION"  
A "AFTER OPERATION"  
W "WEEKLY"  
M "MONTHLY"

(3) Item to be inspected - what should be inspected.

(4) Procedure - how to inspect the item.

(5) For readiness reporting, equipment is not ready/available if- why and when you cannot use your equipment.

**CAUTION**

Under some operating conditions, slight water leaks from some of the pump bearings may be observed. That is normal. If there is any doubt, or if equipment could be damaged, notify the supervisor or unit maintenance.

Table 2-2. (Army) Operator/Crew Preventive Maintenance Checks and Services (Trailer)

**NOTE**

Within designated intervals, perform these checks in the order listed. Perform weekly PMCS as well as BEFORE operations PMCS if:

- (1) You are the assigned operator and have not operated the ROWPU since the last weekly PMCS.
- (2) Operating the item for the first time.

Item No.	Interval					Item to be Inspected	Procedures: Check for and have repaired or adjusted as necessary	Equipment is not ready/available if:
	B	D	A	W	M			
1	•		•			Towing vehicle electrical system	Check that 24 V power supply is available to trailer.	24 V not available.
2		•	•		•	Electrical connector and cable	Check that connector and cable in good condition, insulation unbroken, connector free of dirt and corrosion.	Broken cable or connector.
3	•	•	•	•		Lights	Check that tail light, stoplights, and blackout light work properly.	Light system inoperative.
4			•	•	•	Chassis wiring	Inspect for frayed or worn spots in wiring harness.	Wiring excessively frayed, worn or deteriorated.
5	•	•	•	•		Service brake system	Start engine of towing vehicle to build up air pressure in brake system. Check for proper operation of brakes	Pressure on brake pedal in towing vehicle does not activate trailer brakes.
6	•		•			Air hose couplers	Make sure couplers are securely attached to towing vehicle (or dummy couplers if trailer not attached to a towing vehicle).	Couplers broken.
7	•		•	•		Air hoses	Check for cracks, leaks, or other damage.	Hoses broken or leaking.
8					•	Air brake tubing reservoir, and other components	Inspect for bends, dents, and leaks which may interfere with proper operation.	Parts badly damaged or leaking.
9			•	•		Air reservoir	Drain condensation by opening draincock; close draincock after draining. Check for broken or corroded draincock.	Draincock broken or corroded.

Table 2-2. (Army) Operator/Crew Preventive Maintenance Checks and Services  
(Trailer) (Continued)

Item No.	Interval					Item to be Inspected	Procedures: Check for and have repaired or adjusted as necessary	Equipment is not ready/ available if:
	B	D	A	W	M			
10	•		•	•		Tires	Check for proper inflation (75 psi); be sure tires are not excessively worn. Check that all tires are worn evenly.	Tires flat or below recommended pressure.
11	•		•			Nuts	Make sure lug nuts on wheels and other equipment fasteners have not worked loose. Check that cap nuts are properly seated and tight.	Lug nuts missing.
12					•	Axles, springs	Visually inspect all structural parts for excessive wear, corrosion, broken welds.	Structural parts broken.
13			•	•	•	Trailer frame	Inspect for broken welds.	Welds broken.
14			•	•		Lunette	Inspect for loose or damaged bolts.	Lunette misaligned or loose.
15	•		•			Leveling jack cranks	Check that cranks are in place on support brackets.	
16			•	•	•	ROWPU frame	Inspect for broken welds.	Welds broken.

Table 2-3. Operator/Crew Preventive Maintenance Checks and Services (Unit)

Item No.	Interval				Item to be Inspected	Procedures: Check for and have repaired or adjusted as necessary	For readiness reporting Equipment is not ready/available if:
	B	D	A	W			
1	•	•	•		ROWPU, General	<p>Inspect the general appearance of the unit, paying particular attention to the words on identification markings and the condition of the paint. Inspect for rust, especially on weldments.</p> <p>Inspect for water leaks; loose or missing bolts, screws, nuts, and hoses. Inspect for damage since the equipment was last used. Inspect for loose or broken cable connections.</p>	
2	•		•		Tools and Equipment	<p>Inspect tools and toolbox</p> <ul style="list-style-type: none"> <li>• Good shape</li> <li>• Clean</li> <li>• All there</li> <li>• In proper place</li> <li>• Box mounts solid</li> <li>• Box closes properly</li> </ul>	
3					Vent and drain lines	<p>Check vent and drain line connections</p> <ul style="list-style-type: none"> <li>• Solid</li> <li>• Any damage</li> <li>• No obstructions</li> </ul>	Lines are broken or clogged
4					Frame and equipment	<p>Remove oil, grease, mud chemical spills, and other matter from all parts of the ROWPU. Use clean cloths. Wash the floor with product water.</p>	
5	•	•	•		Multimedia filter	<p>Inspect for leaky gaskets, and loose mountings. Notify unit maintenance if you find trouble. Check multimedia gage readings. Should read within 5 psid of initial log reading, and in no case exceed 10 psid. or 10 psid.</p>	Raw water will not flow through filter. Filter cannot be back-washed. Gage reading exceeds either 5 psid of initial log reading
						<b>2-22</b>	

Table 2-3. Operator/Crew Preventive Maintenance Checks and Services  
(Unit) (Continued)

Item No.	Interval				Item to be Inspected	Procedures: Check for and have repaired or adjusted as necessary	For readiness reporting Equipment is not ready/available if:
	B	D	A	W			
6			•		Cartridge filter	Check for leaks. Check cartridge filter gage readings. Should be 1-20 psid.	Raw water will not flow through filter. Gage reads over 20 psid.
7	•	•	•		Gages and flow indicators	Inspect for broken glass. Look for loose mountings and tube connections.	Gages or flow indicators are in-operative.
8	•		•		Frames: ROWPU BACKWASH PUMP, DISTRIBUTION PUMP, RAW WATER PUMPS	Inspect for damaged or bent frames, loose mounting bolts, and missing or broken tiedowns and frame pins. Inspect crossmembers and beams for cracks and breaks. Tighten loose mounting bolts. Report breaks, misfits, cracks, damaged framework, or missing hardware to unit maintenance.	Outlying pumps cannot be set due to frame damage.
9				•	Canvas items: frame cover, pump covers, holddown straps	Inspect for rips, tears, or other damage. Report damaged items to unit maintenance.	
10	•	•	•		Hoses, tanks, piping, tubing, fittings, strainers, and nozzle	Inspect for leaks. Look for hose or pipe blockages. Are parts cracked or broken? Tighten loose connections.  <b>CAUTION</b>  Don't overtighten. It will ruin threads. Stripped threads will cause connections to leak. Replace damaged raw water strainer, chemical feed pumps strainer, backwash pump filters, and distribution nozzle. Report a leaky tank to unit maintenance. Replace damaged hoses.	There is not enough undamaged hose to set up the ROWPU. Neither product water tank will hold water.
						<b>2-23</b>	



Table 2-3. Operator/Crew Preventive Maintenance Checks and Services (Unit) (Continued)

Item No.	Interval				Item to be Inspected	Procedures: Check for and have repaired or adjusted as necessary	For readiness reporting Equipment is not ready/available if:
	B	D	A	W			
11	•	•	•		Chemical feed equipment: plastic pails, tubes, strainers and cans	<p>Inspect container/rack, pails, cans and tubes for cuts, cracks or holes. Inspect during operation for leaks</p> <p>Inspect strainer for clogging. After operation, drain and clean pails, tubes, strainers and cans. draw chemicals into the pumps.</p>	<p>Pails are so damaged that they will not hold chemicals. Tubes will not</p>
12	•	•	•		Chemical feed pump	<p>Inspect for loose mounting nuts. Inspect for cracked or broken fitting. Check oil level before operation. Add oil as necessary. Refer to LO 5-4610-215-12/ LI 08580B-12. Listen for unusual noises during operation. Notify unit maintenance to replace malfunctioning pump. For sight glass location and oil filling instructions, see lubrication order LO 10-4610-239-12/LI 08580B-12</p>	<p>Any one of the four pumps will not supply chemical to the purification cycle.</p>
13	•	•	•		Chemical feed pump motor	<p>Check for loose mounting nuts and bolts. Look for loose wires at conduit box. Listen for unusual noises during operation. Notify unit maintenance to replace malfunctioning motor.</p>	<p>Motor will not operate.</p>
14	•	•	•		Chemical feed pump priming valves	<p>Inspect for broken or missing pipe nipples. Check for free operation of valve handles. Check for chemical corrosion.</p>	<p>Valves will not prime chemical feed pump.</p>

Table 2-3. Operator/Crew Preventive Maintenance Checks and Services  
(Unit) (Continued)

B - Before

D - During

A - After

H - Hourly Interval

Item No.	Interval				Item to be Inspected	Procedures: Check for and have repaired or adjusted as necessary	Equipment Is Not Ready/ Available If:
	B	D	A	W			
15	•	•	•		Color comparator kit, TDS meter	Inspect the color comparator kit and TDS meter. Look for: <ul style="list-style-type: none"> <li>• Poor condition</li> <li>• Dirty sample cells</li> <li>• Dirty color discs</li> <li>• Cracked or dirty frosted glass</li> <li>• Clean as necessary.</li> </ul> Notify unit maintenance if any part is defective.	
16	•	•	•		Regulate product flow valve and backwash valve	Inspect for loose hose connections. Inspect valves to see if they operate freely and do not leak. Tighten loose connections. Notify unit maintenance if valves bind or leak.	Valves will not operate.
17		•	•		Vent and drain valves and drain Cocks.	Inspect for leaks and proper operation Notify unit maintenance if you notice anything wrong.	Valves will not operate.
18	•			•	Junction Box	<p style="text-align: center;"><b><u>WARNING</u></b></p> Do not operate ROWPU with an open junction box; it can kill you.	
19	•		•		Control box assembly and Junction box assembly	Inspect for outside damage Clean out dirt and dust collected in them. Use test indicator lights switch to ensure indicator lamps are functioning properly.	Any toggle switch except PANEL LIGHT is broken.
2-25							

Table 2-3. Operator/Crew Preventive Maintenance Checks and Services  
(Unit) (Continued)

B - Before

D - During

A - After

H - Hourly Interval

Item No.	Interval				Item to be Inspected	Procedures: Check for and have repaired or adjusted as necessary	Equipment Is Not Ready/ Available If:
	B	D	A	W			
						<p align="center"><b><u>WARNING</u></b></p> <p>Do not operate ROWPU with an open box assembly; it can kill you</p> <p>Inspect the plug connectors, toggle switches, and lamps for loose mountings and bad parts. Replace lamps that don't work. See that the junction box is securely mounted and kept closed.</p>	
20	•				R.O. pump drive belt guard	Inspect belt guard for loose mounting bolts. Tighten all Studs, nuts, and capscrews.	Belt guard off or hanging.
21	•				R.O. Pump drive belts.	Check all five V-belts for cracks, Rubbing, and signs of wear. Check belt tension: You should be Able to push belts down only a half- inch at center of span.	Belt tension Adjustment; belts are defective.
22	•				R.O. pump, wiring, motor mounts, head gasket, and piping	Inspect wire connection going to junction box. Inspect the motor mounts for cracks or breaks. Look for dirt, corrosion, or water damage. Check for head gasket leaks and piping leaks.	
						<p align="center"><b><u>WARNING</u></b></p> <p>P-D-680 is potentially dangerous. Avoid repeated and prolonged breathing of vapors and skin contact with the liquid. Do not use near open flame, arcing equipment or other ignition sources. Always wear protective clothing and eyewear.</p>	
						2-26	

Table 2-3. Operator/Crew Preventive Maintenance Checks and Services  
(Unit) (Continued)

B - Before

D - During

A - After

H - Hourly Interval

Item No.	Interval				Item to be Inspected	Procedures: Check for and have repaired or adjusted as necessary	Equipment Is Not Ready/ Available If:
	B	D	A	W			
23		•		•	R.O. Pump Motor	<p>Wipe motor with a clean cloth dampened with an approved cleaning solvent (P-D-680).</p> <p>Check oil level and lubricate in accordance with lubricating order, LO 10-4610-239-12/LI 08580B-12</p> <p>Inspect for signs of overheating or too much wear.</p> <p style="text-align: center;"><b>NOTE</b></p> <p>A new pump may run hotter for a few days. Change oil before first startup; watch oil level during break-in period.</p> <p>Listen for uneven, knocking sound</p>	Motor makes unfamiliar sounds during operation.
24		•			R.O. Pump drain tube end	Inspect drain tube end to ensure that drain is open Open restricted drain.	Drain clogged and cannot be cleared.
25		•			R.O. Pump cavity seals and plungers	<p>Remove the wing nut and cover plate which are located at the top center of pump with rubber splash guards are now exposed. Using spanner wrench, tighten packing nut.</p> <p>Inspect R.O. pump cavity to make sure excessive leakage is not occurring:</p> <p style="text-align: center;"><b>CAUTION</b></p> <p>Excessive leakage will contaminate the oil and score the plungers.</p>	Plungers equipped  Water level in R.O. pump cavity rises near plungers during operation.
2-27							

Table 2-3. Operator/Crew Preventive Maintenance Checks and Services  
 (Unit) (Continued)

B - Before

D - During

A - After

H - Hourly Interval

Item No.	Interval				Item to be Inspected	Procedures: Check for and have repaired or adjusted as necessary	Equipment Is Not Ready/ Available If:
	B	D	A	W			
26				•	Low- and high-pressure switches and toggle switches	<p>Water leaking into the cavity past the seals (packing) is normal. The pump is designed such that accumulated water will be drained from the cavity through the plastic drain tube to the ground. However, as the packing and plungers wear from normal operation, the water leakage will become more severe. When the drain tube can no longer accommodate the flow, the cavity will fill with water, which could enter the crankcase and contaminate the oil.</p> <p>If the water level rises near the plungers, the packing and the plungers, if scored, must be replaced. Report this condition to unit maintenance.</p> <p>Inspect for dust or dirt            Inspect for loose or damaged wires.            Report loose or damaged wires to unit maintenance</p>	Toggle switches are broken. Switch cases are broken. Bare wires are visible.
27	•	•	•		Pump assemblies	<p>Inspect the pumps for loose mountings, damaged frames, cracked housings, and leaky seals.</p> <p>Inspect pumps for unobstructed, clockwise rotation.</p> <p>Listen for unusual noises from pumps or pump motors during operation.</p>	Raw water pumps or booster pump do not work.
28	•		•		Cable assemblies	<p>Inspect electrical cable assemblies for cracked, broken or cut insulation</p> <p>Inspect connectors on ends of cables.</p> <p>Report any unserviceable cable assembly to unit maintenance.</p>	Cables are broken or bare wires are visible.

Table 2-3. Operator/Crew Preventive Maintenance Checks and Services  
(Unit) Continued

B - Before

D - During

A - After

H - Hourly Interval

Item No.	Interval				Item to be Inspected	Procedures: Check for and have repaired or adjusted as necessary	Equipment Is Not Ready/ Available If:
	B	D	A	W			
29	•	•			Backwash timer	Inspect outside for cleanliness Inspect for loose wiring Wipe dirt from timer. Report a nonoperating timer to unit maintenance.	Backwash timer does not work.
30	•			•	Ground rod	Inspect for damaged ground wire connections, and loose, damaged, or missing screw joints and driving bolt. Clean and tighten ground connections and screw joints. Report unserviceable ground rods to unit maintenance.	There is only one usable section of ground rod.
31				•	Data and instruction holders and plates	Inspect for damage and for missing parts.	
32		•			R.O. vessel assemblies	Inspect for damage (cracks, breaks, leaks), and loose or missing mounting hardware Tighten loose hardware Report damaged assemblies to unit maintenance.	Any R.O. vessel is cracked or broken; R.O. vessels leak around seals.
33	•	•	•	•	30 kW generator set (Army)	Inspect and service generator set as shown in applicable manual for generator (TM 5-6115-465-12 for NSN 6115-00-118-1240).	
34	•		•		(Army) Portable step	Inspect for rust and cracked or broken weldments.	
35	•		•		Storage boxes	Inspect for broken panels. Check for broken or missing hardware. Report damage to unit maintenance.	
36	•	•	•		Special tools: paddle, valve seat puller, R.O. element puller, pilot bulb puller	Inspect for bent shafts and stripped threads. Replace damaged tools.	

Table 2-3. Operator/Crew Preventive Maintenance Checks and Services  
(Unit) (Continued)

B - Before

D - During

A - After

H - Hourly Interval

Item No.	Interval				Item to be Inspected	Procedures: Check for and have repaired or adjusted as necessary	Equipment Is Not Ready/ Available If:
	B	D	A	W			
37	•		•		Circuit breakers	Inspect for cracked or broken parts. Before connecting generator set, check for free movement of handle. Inspect for signs of burning or arcing.	Any circuit breaker is damaged or will not move easily
38	•	•	•		Water testing equipment: lab beaker, graduated cylinder, solution indicator, thermometer	Check for cracked or broken glass. Check to see that all markings are readable. Replace damaged items.  <b><u>CAUTION</u></b>  To avoid damaging rupture disc, do not overtighten the holddown screw. Handtighten, then tighten 1/8 turn with wrench.	
39	•				Rupture disc assembly	Before operation make sure an intact rupture disc is in place Check for leaks around rupture disc assembly	An intact rupture disc is not in place. There is leakage around rupture disc seat.
40	•	•			Pulse dampener	Inspect for broken, rusted, or missing mounting hardware. Check for cracks on weldment. Inspect for leaks.	There is any damage to weldment.
41	•	•			High-pressure relief valve	Inspect for rust. Check for leakage at base of relief valve.	There is leakage at relief valve union to pipe.
42	•				In-line TDS monitor	Inspect for damage. Install on control panel.	Visual damage.
43					Water meter	Inspect for damage. Ensure cover is closed when readings are not being taken.	Visual damage.

### SECTION III. OPERATION UNDER USUAL CONDITIONS

**2-21. CHOOSING THE SITE.** When choosing the site to set up and run the ROWPU, remember the following:

- a. If a stream is to be used as the raw water source, pick a site for the ROWPU upstream from camp.

#### WARNING

Ensure that the site provides downstream waste water drainage away from the water source.

#### CAUTION

Consider variable weather conditions when choosing site; avoid areas vulnerable to flash flooding.

#### NOTE

Illustration denotes Army ROWPU. MC unit is skid mounted.

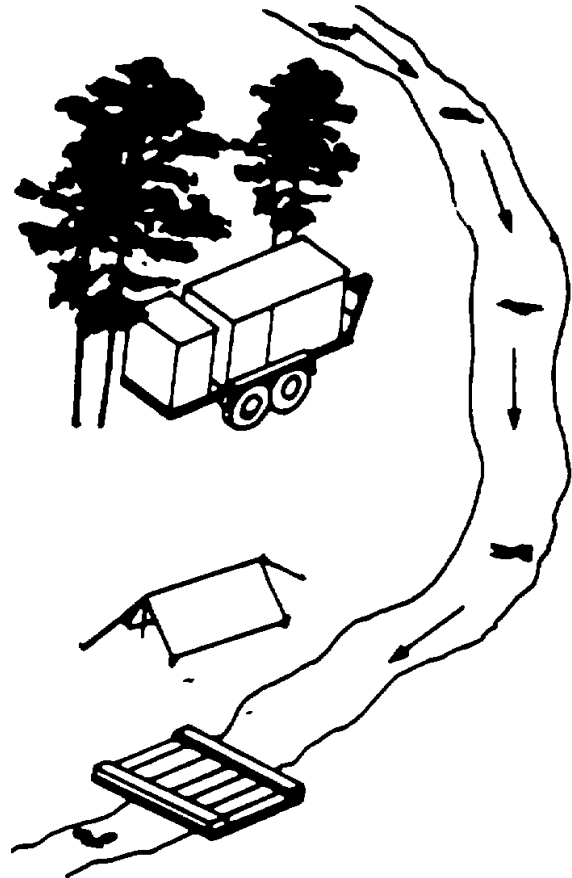

Figure 2-16. Site Diagram

- b. The raw water hoses can reach about 75 feet. Ensure the ROWPU is placed close enough for the hoses to reach the stream or lake, and check that the ground is solid and fairly level.
- c. Take advantage of available forest cover.
- d. Take advantage of finished roads. They can furnish a solid, level surface.

**2-22. PREPARATION FOR USE.** Upon reaching the operating area, prepare the ROWPU for operation. For Army unit, refer to figures 2-17 (Model No. 0996109001) and 2-18 for trailer set-up, then follow para. 2-22a through 2-22 ad. For skid-mounted units (Model No. 0996108001), skip to para. 2-22 a through 2-22 ad.



1. CHOOSE A SITE AS NEARLY LEVEL AS POSSIBLE; CLEAR SITE OF ROCKS AND VEGETATION. BE SURE SURFACE IS FIRM ENOUGH TO SUPPORT THE TRAILER-MOUNTED ROWPU.

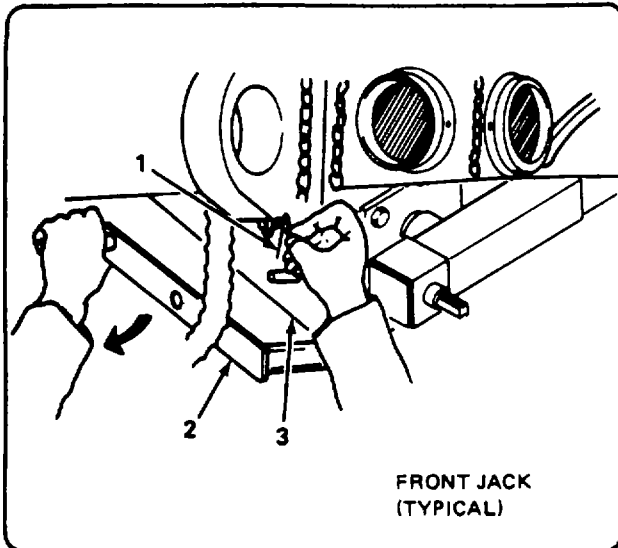

3. REMOVE SAFETY PIN (1) AND CRANK HANDLE (2) FROM REAR OF JACK SUPPORT BRACKET (3).

2. MANEUVER TRAILER INTO POSITION WITH TOWING VEHICLE. BE SURE ALL SIDES OF TRAILER, AND ALL FITTINGS AND CONTROLS FOR THE ROWPU ARE EASILY ACCESSIBLE. IF TOWING VEHICLE IS TO BE DISCONNECTED FROM TRAILER, USE FRONT LEVELING JACKS TO HELP IN UNCOUPLING.

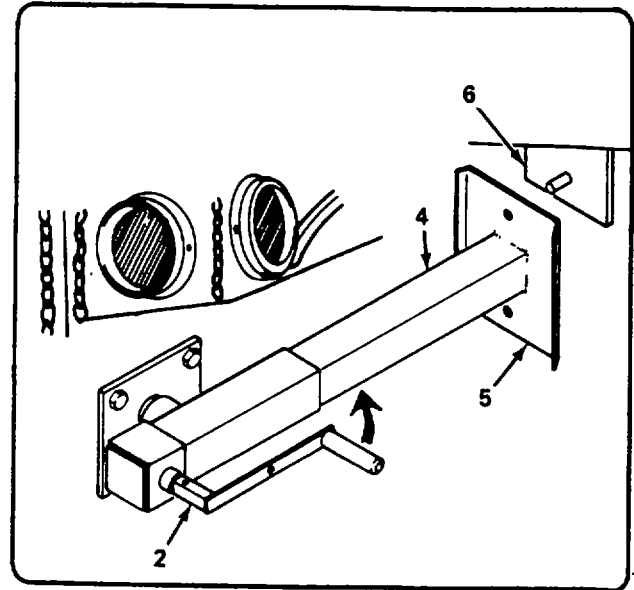

4. POSITION CRANK HANDLE (2) ON JACK (4) AND TURN HANDLE COUNTERCLOCKWISE TO RETRACT JACK UNTIL JACK PAD (5) IS CLEAR OF SECURITY PLATE (6) ROUND BAR.

**WARNING:** Leveling jack is spring loaded. Use Care when pulling out leveling jack to prevent personal injury.

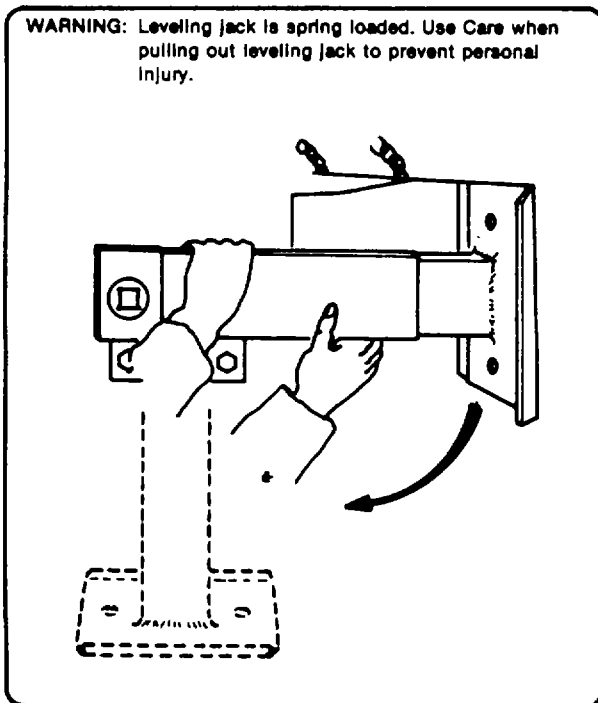

5. TO ROTATE FRONT LEVELING JACK TO LEVELING POSITION, REMOVE CRANK HANDLE. GRASP JACK AND PULL STRAIGHT OUT AGAINST SPRING TENSION. ROTATE JACK DOWN TO VERTICAL POSITION. ALLOW JACK TO SPRING BACK TO LOCKED POSITION.

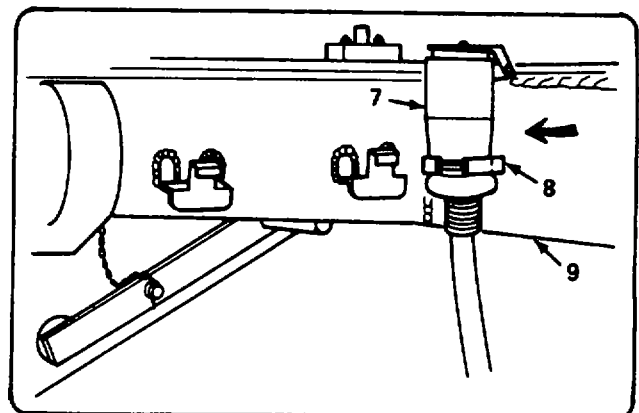

6. DISCONNECT ELECTRICAL CONNECTOR (7) FROM TOWING VEHICLE. STOW CONNECTOR IN STOWAGE CLIP (8) ON TRAILER DRAWBAR (9).

Figure 2-17. Preparation For Use (Sheet 1 of 4)  
(Army Model No. 0996109001)

NOTE: Two personnel operating both front leveling jacks are required to raise the trailer.

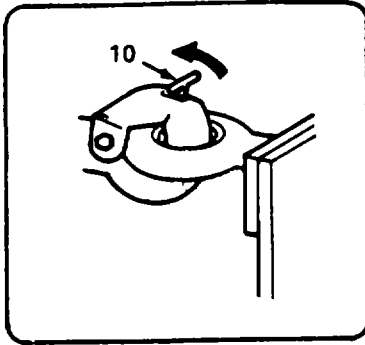

7. RELEASE PINTLE (10) BY LIFTING PINTLE LEVER. RAISE PINTLE.

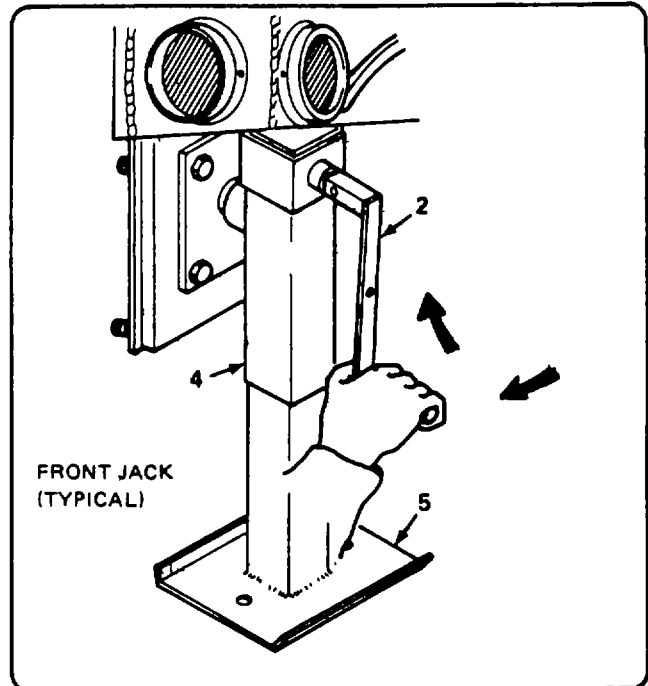

8. POSITION CRANK HANDLE (2) ON JACK (4) AND TURN HANDLE CLOCKWISE TO LOWER JACK PAD (5). CONTINUE TO LOWER BOTH FRONT JACKS UNTIL WEIGHT OF TRAILER RESTS ON JACKS INSTEAD OF TOWING VEHICLE, AND LUNETTE IS CLEAR OF PINTLE.

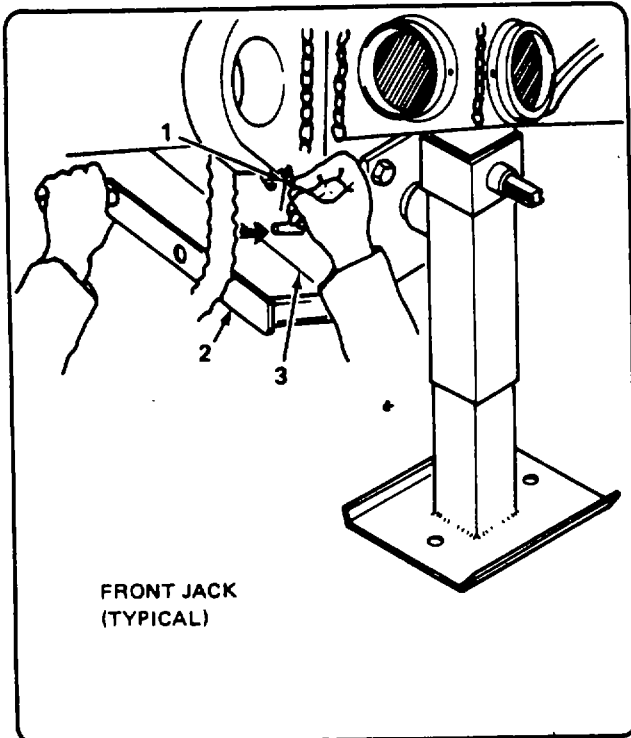

9. REPLACE CRANK HANDLE (2) ON REAR OF JACK SUPPORT BRACKET (3); INSTALL SAFETY PIN (1).

Figure 2-17. Preparation For Use (Sheet 2 of 4)  
(Army Model No. 0996109001)

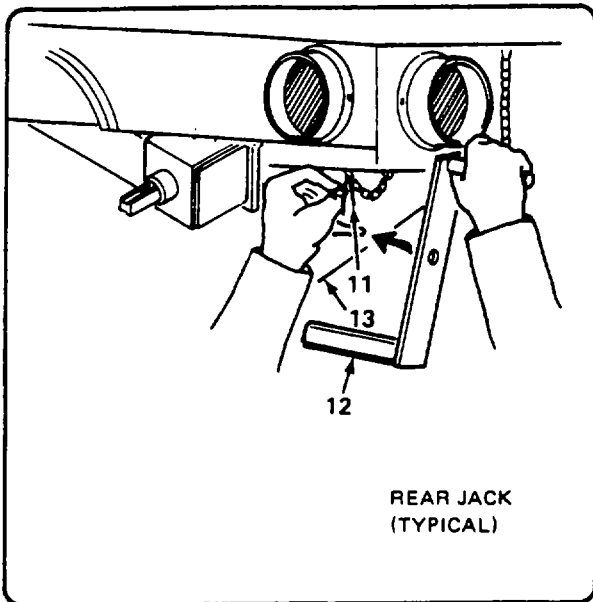

10. REMOVE SAFETY PIN (11) AND CRANK HANDLE (12) FROM REAR OF JACK SUPPORT BRACKET (13).

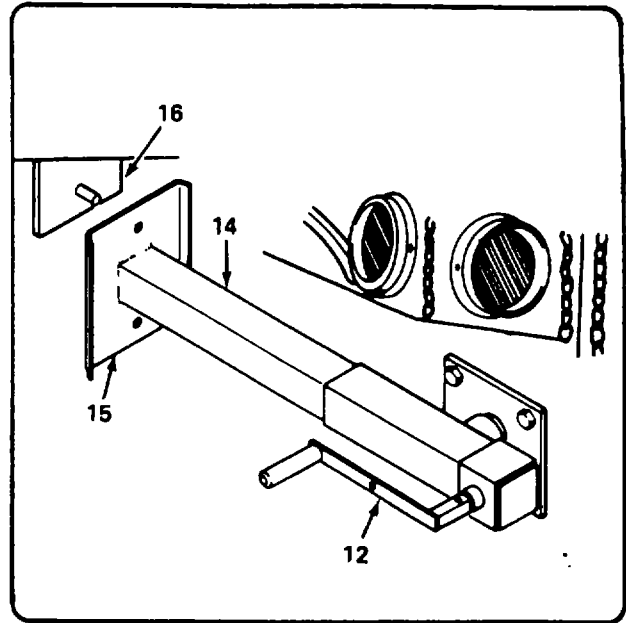

11. POSITION CRANK HANDLE (12) ON JACK (14) AND TURN HANDLE COUNTERCLOCKWISE TO RETRACT JACK UNTIL JACK PAD (15) IS CLEAR OF SECUREMENT PLATE (16) ROUND BAR.

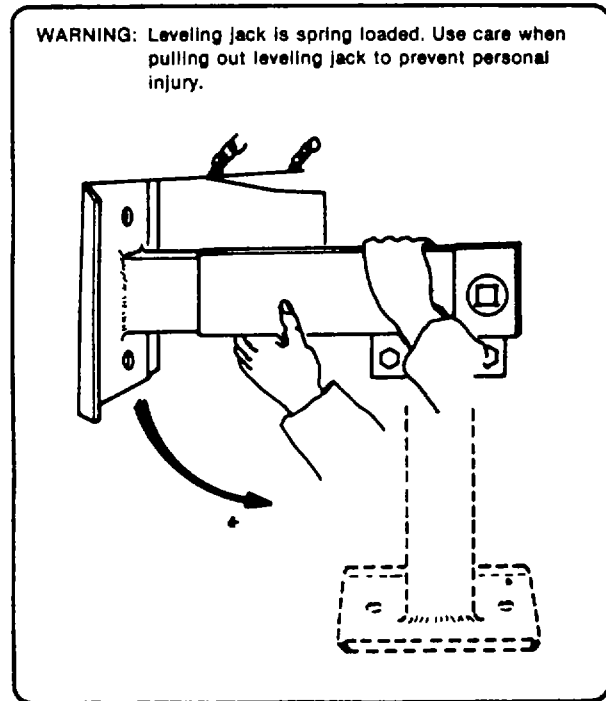

12. TO ROTATE REAR LEVELING JACK TO VERTICAL POSITION, REMOVE CRANK HANDLE. GRASP JACK AND PULL STRAIGHT OUT AGAINST SPRING TENSION. ROTATE JACK DOWN TO VERTICAL POSITION. ALLOW JACK TO SPRING BACK TO LOCKED POSITION.

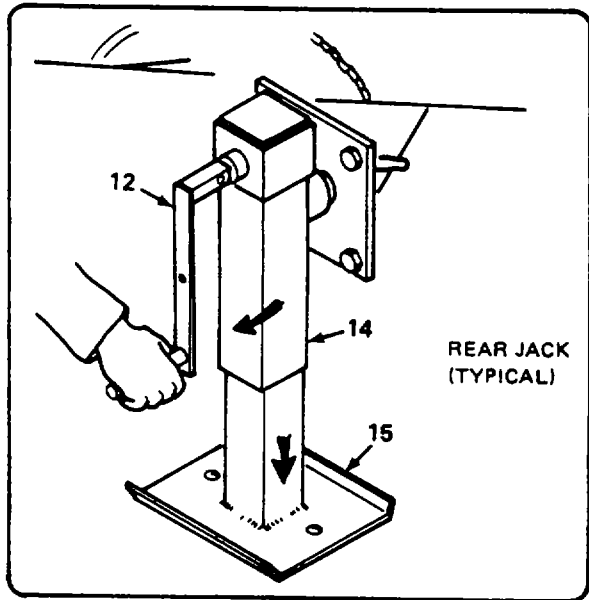

13. POSITION CRANK HANDLE (12) ON JACK (14) AND TURN HANDLE CLOCKWISE TO LOWER JACK PAD (15). CONTINUE TO LOWER BOTH REAR JACKS UNTIL JACK PADS REST FIRMLY ON THE GROUND.

Figure 2-17. Preparation For Use (Sheet 3 of 4)  
 (Army Model No. 0996109001)

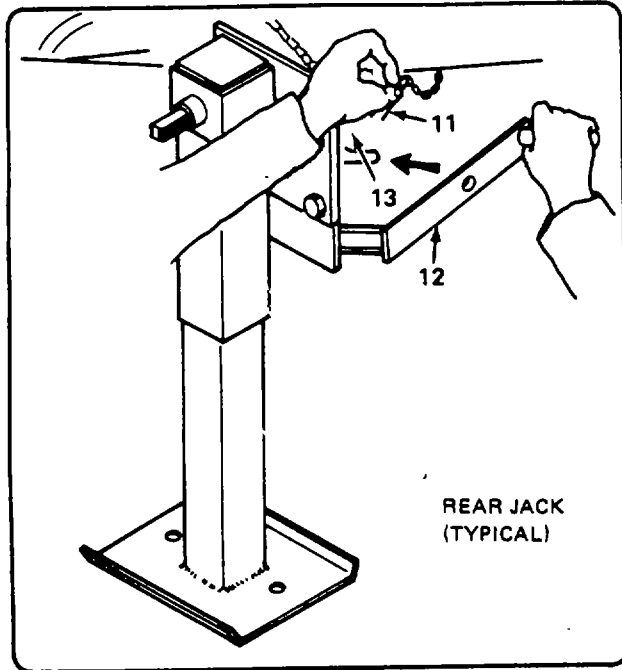

14. REPLACE CRANK HANDLE (12) ON REAR OF JACK SUPPORT BRACKET (13); INSTALL SAFETY PIN (11).

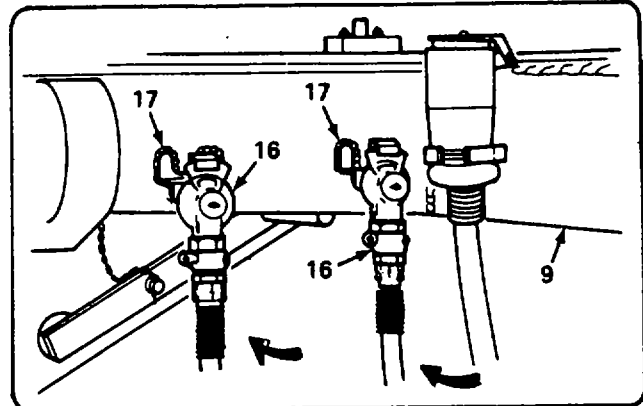

15. CLOSE AIR BRAKE COUPLING LEVERS. DISCONNECT AIR HOSES (16) FROM TOWING VEHICLE. PARKING BRAKES ARE NOW SET. STOW AIR HOSES (16) ON DUMMY COUPLINGS (17) PROVIDED ON TRAILER DRAWBAR (9).

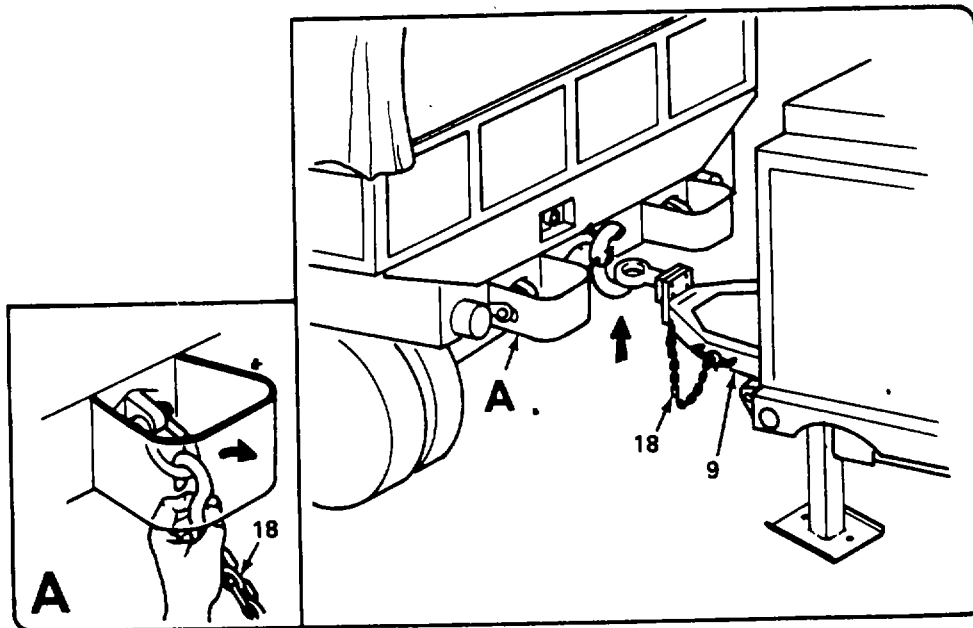

16. DISCONNECT TRAILER SAFETY CHAIN (18) FROM TOWING VEHICLE. PLACE TRAILER SAFETY CHAIN (18) IN STOWED POSITION ON TRAILER DRAWBAR (9).

Figure 2-17. Preparation For Use (Sheet 4 of 4)  
(Army Model No. 0996109001)

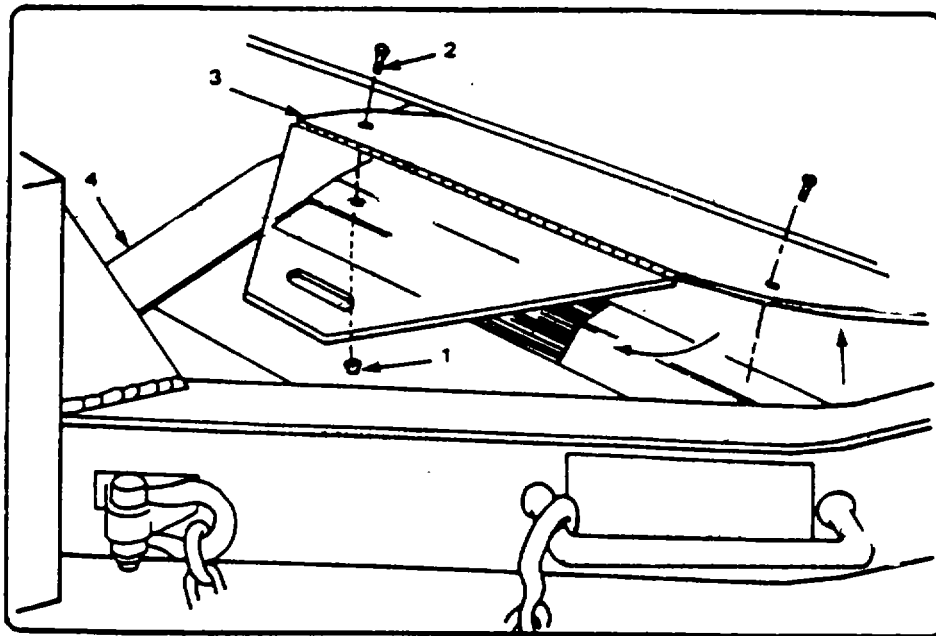

1. REMOVE NUTS (1) AND SCREWS (2) SECURING SAFETY STEP (3) IN PLACE. LAY SAFETY STEP DOWN ON DRAWBAR (4) AND INSTALL PREVIOUSLY REMOVED NUTS AND SCREWS.

Figure 2-18. Unfold Safety Step (Army)

- a. Roll up the canvas cover over the ROWPU frame and fasten with tie-back straps.

**NOTE**

Illustration denotes Army ROWPU. MC units are skid mounted.

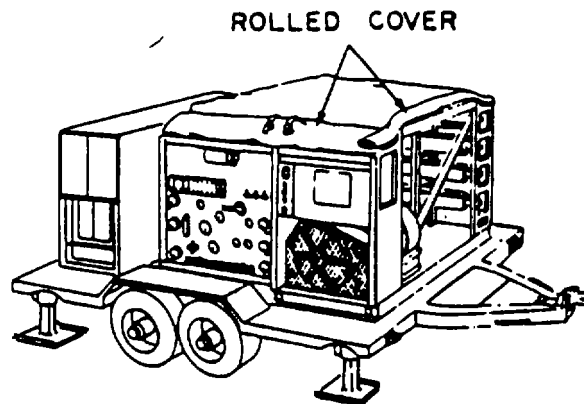
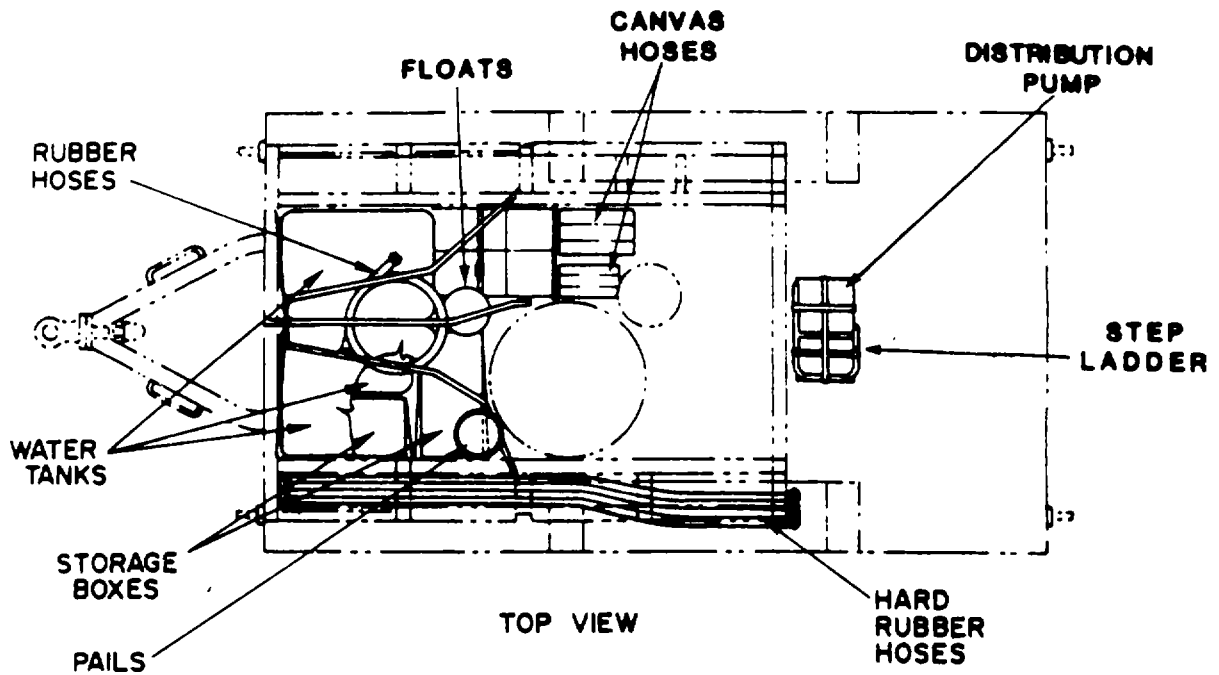

Figure 2-19. Canvas Cover Tied Back

b. Looking at the ROWPU from above, with canvas removed, you can see various items stored.



**NOTE**

MC units are skid mounted with a separately packed distribution pump and without a step ladder. Army Model 0996109001 and MC Model No. 0996108001 also have chemical feed containers/rack (11, fig. 1-13.)

*Figure 2-20. Top View of ROWPU*

c. Remove the two frame cross braces. Store them on top of ROWPU canvas. Release cargo straps by loosening the sawtooth (ratchet) holders. Unsnap hooks on bottom of straps. Roll up cargo straps and put them on top of ROWPU canvas.

**NOTE**

Illustration denotes Army ROWPU. MC units are skid-mounted.

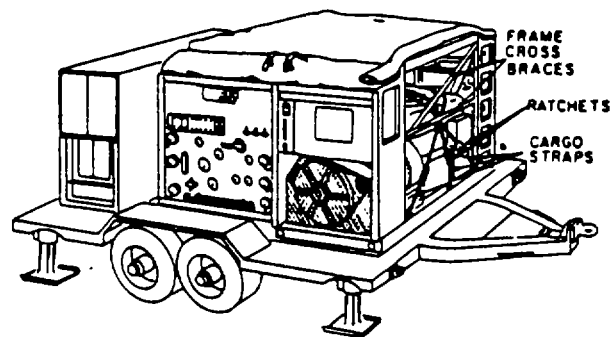

Model No. 0996109001

*Figure 2-21. Cross Braces, Cargo Straps, Ratchets*

- d. Remove one suction hose float and five utility pails.

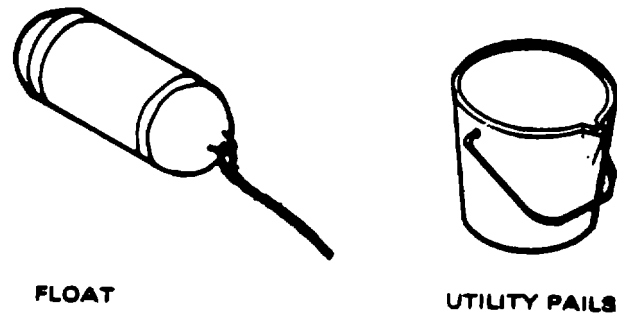

Figure 2-22. Suction Hose Float and Utility Pails

- e. Remove three hard rubber suction hoses that are used for raw water input. Be careful not to damage threaded ends.

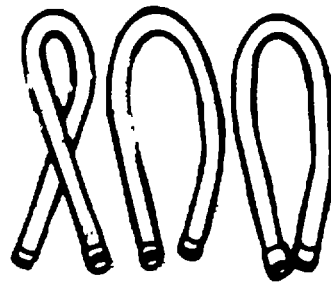

Figure 2-23. Rubber Hoses

- f. Remove from ROWPU overpack:

One brine tank, (6).

Two product water tanks, (7) and (8).

Tank supports, guy ropes.

Tank ground cloths and covers.

Paddle, (12).

Sledge hammer, (11).

Chemical feed containers, (16)

One 2-inch and nine 1 1/2-inch suction (hard rubber) hoses (13); nine discharge (canvas) hoses; three 2-inch and six 1 1/2-inch hoses.

Storage boxes (9) and (10) (remove but do not unpack).

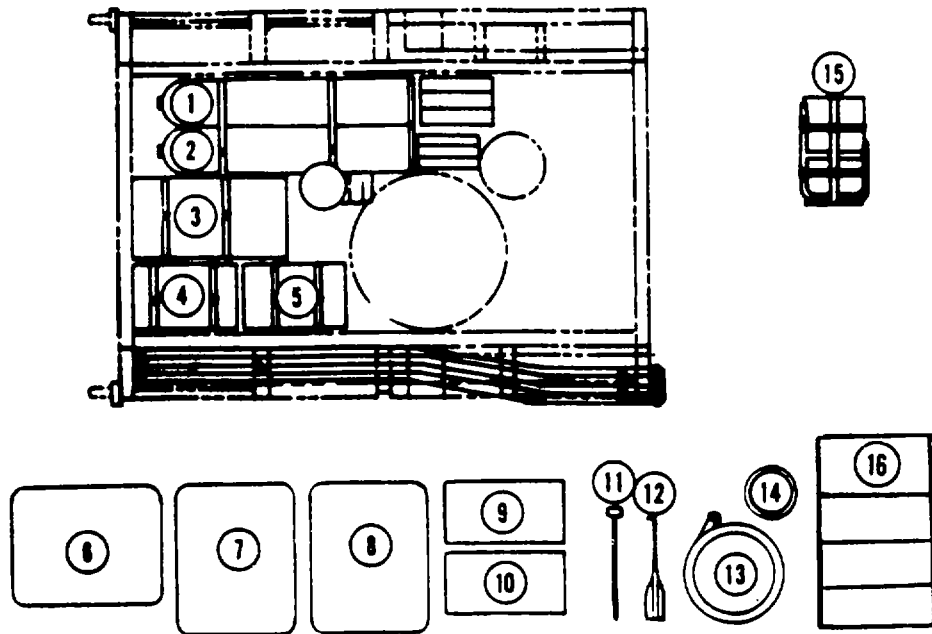

- |            |                    |     |                          |
|------------|--------------------|-----|--------------------------|
| 1. and 2.  | NBC Tanks          | 11. | Sledge Hammer            |
| 3.         | Backwash Pump      | 12. | Paddle                   |
| 4. and 5.  | Raw Water Pumps    | 13. | Suction Hose             |
| 6.         | Brine Tank         | 14. | Pails                    |
| 7. and 8.  | Product Water Tank | 15. | Distribution Pump        |
| 9. and 10. | Storage Boxes      | 16. | Chemical Feed Containers |

Figure 2-24. Top View of ROWPU and Overpack

**NOTE**

Only two storage boxes exist. They are labeled "Storage Box No. 2" and "Storage Box No. 3".



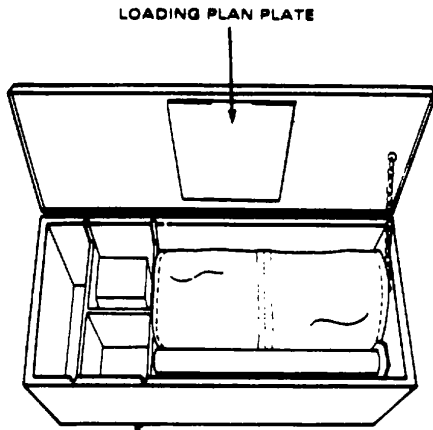

Figure 2-25. Storage Box No. 2

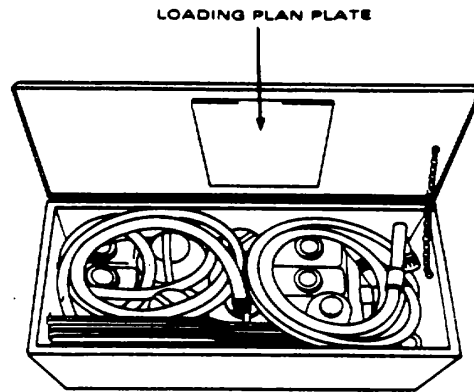

Figure 2-26. Storage Box No. 3

g. Inspect storage boxes to ensure they contain all items as listed in Appendix B.

h. Release hold-down straps over the two raw water pumps (1). Remove canvas covers. Lift both raw water pumps off the ROWPU.

**WARNING**

To avoid injury, get help to lift backwash pump.

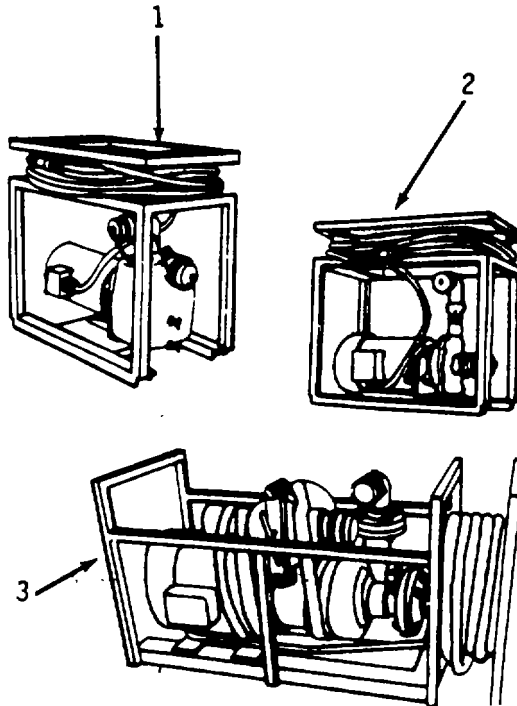

Figure 2-27. Outboard Pumps

- i. Release straps over the backwash pump (3) and remove cover. Remove pump from ROWPU.
- j. (Army) The distribution pump (2) is fastened to the rear platform of the ROWPU trailer. It is packaged for two men to carry (portable). Release hold-down straps, remove the ladder and canvas cover, then remove the distribution pump from trailer.
- k. (MC) The distribution pump (2) is packaged for two men to carry (portable), and is separate from unit. Remove packing material and canvas cover from pump.

**NOTE**

The portable total dissolved solids (TDS) meter is factory calibrated to give conductivity characteristics closely representing natural fresh waters. When treating seawater and brackish water, it will be necessary to recalibrate the meter (para. 2-32c(2) or para. 2-32c(3)) in order to get accurate readings on the product water and raw water.

- l. Open the chemical storage box (box No. 2). Take out the calibrated measuring container (sample beaker) and the portable total dissolved solids (TDS) meter.

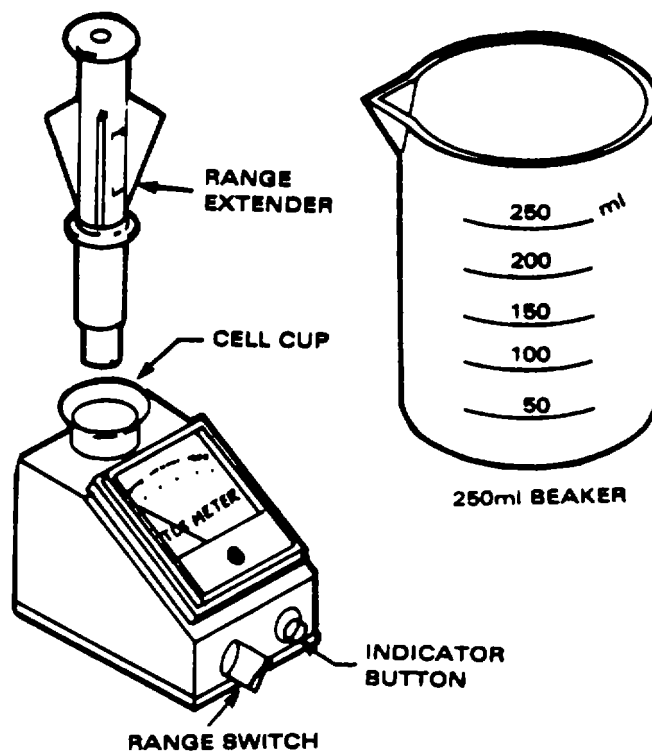

Figure 2-28. Total Dissolved Solids (TDS) Meter (Portable)

**NOTE**

This in-line TDS monitor is factory calibrated to give conductivity characteristics closely representing sea water and brackish water. This monitor cannot be recalibrated in the field. When treating natural fresh water, the TDS reading will not be accurate, but may be used for comparison purposes.

- m. Remove in-line TDS monitor from storage box No. 3. Carefully unpack and install on control panel (fig. 2-29) by sliding into brackets. Secure with pin. Install each plug in proper receptacle.

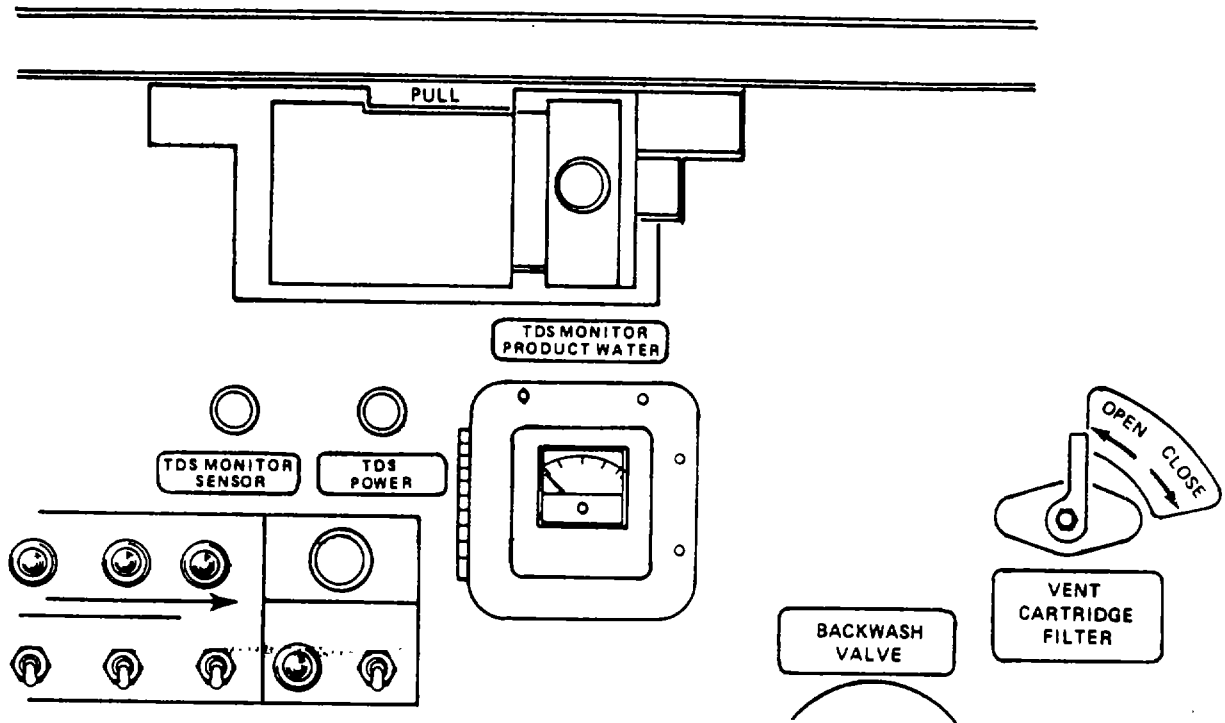
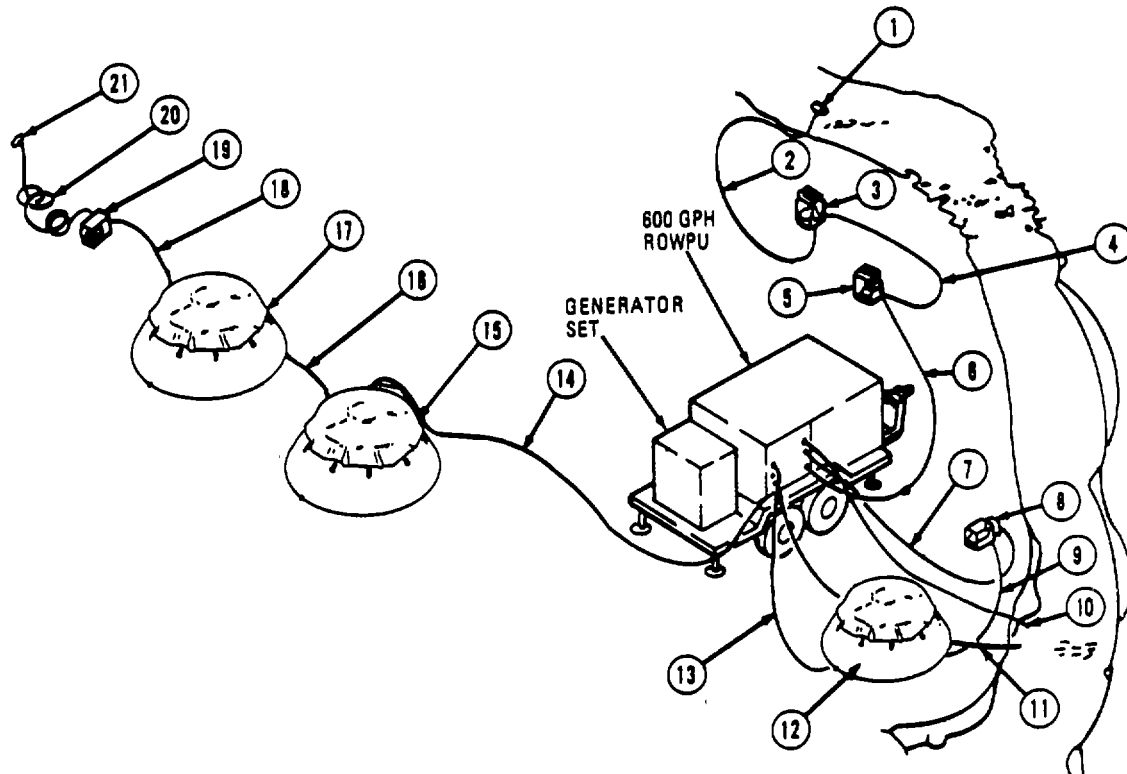

Figure 2-29. In-Line TDS Monitor Location

n. Position operational equipment as shown in fig. 2-30 before starting initial installation.

**CAUTION**

Avoid kinking or excessive looping of hoses.



**NOTE**

Illustration denotes Army model. MC unit is skid mounted.

- |  |   |
|--|---|
| 1. Float and strainer                    | 12. Brine water tank                      |
| 2. Three 1 1/2 inch suction hoses        | 13. Brine 1 1/2-inch discharge hose       |
| 3. Raw water pump                        | 14. Two 1 1/2-inch suction hoses          |
| 4. Two 1 1/2 inch suction hoses          | 15. Product water tank                    |
| 5. Raw water pump                        | 16. Product water 1 1/2-inch suction hose |
| 6. Three 1 1/2 inch discharge hoses      | 17. Product water tank                    |
| 7. Backwash discharge hose (2-inch)      | 18. Product water 1 1/2-inch suction hose |
| 8. Backwash pump                         | 19. Distribution pump                     |
| 9. Backwash 2-inch hard rubber hose      | 20. Product water 1 1/2-inch canvas hose  |
| 10. Waste water 2-inch discharge hose    | 21. Distribution nozzle                   |
| 11. Vent vessels discharge hose (2-inch) |   |

Figure 2-30. Typical Field Installation

- o. Refer to TM 5-543-225-12&P for setup, operation and maintenance of the 3,000 gallon self-supporting tank.

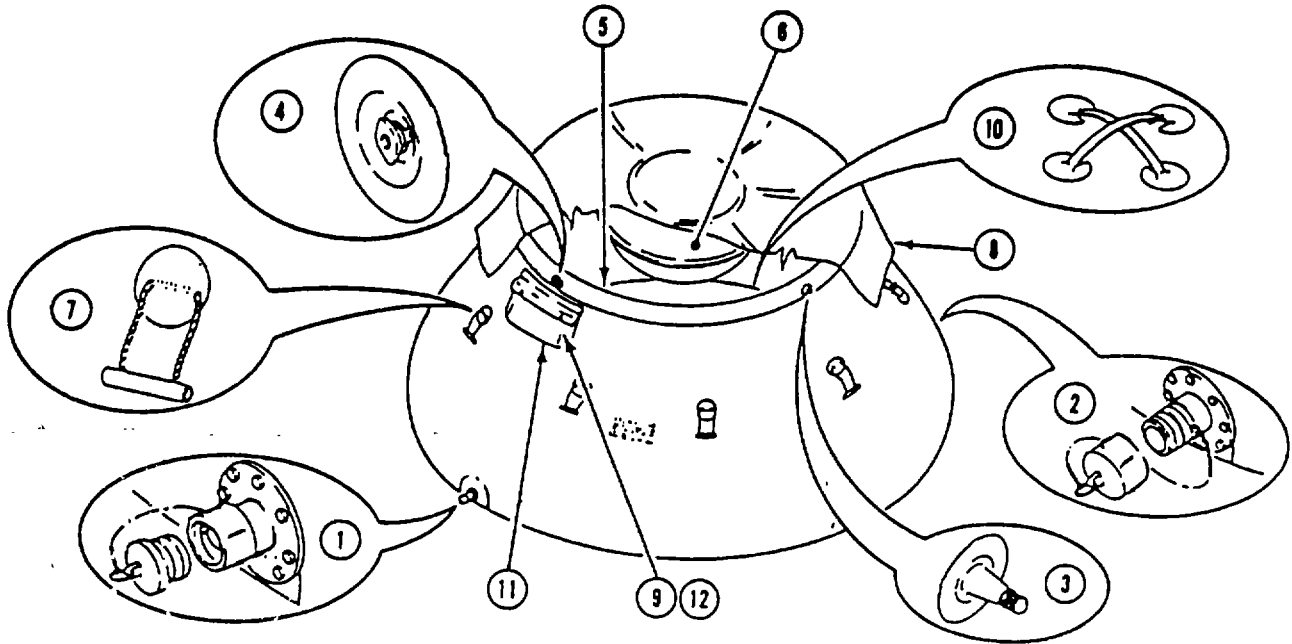

(Inside Pouch)

- |                      |                   |                  |
|----------------------|-------------------|------------------|
| 1. Filler Fitting    | 5. Tank Collar    | 9. Foot Bellows  |
| 2. Discharge Fitting | 6. Cover Float    | 10. Left Handles |
| 3. Automotive Valve  | 7. Handle Toggles | 11. Repair Pouch |
| 4. Inflation Valve   | 8. Cover          | 12. Repair Kit   |

Figure 2-31. Typical Water Tank Installation

p. Attach float to strainer with enough rope to allow strainer to go under water but not touch bottom. Avoid placing the strainer near sandy areas. Hook up raw water system (fig. 2-32). Use only enough hose to reach from the water source to the ROWPU.

**CAUTION**

Ensure all hose connections are tight and seals are in place. Raw water pumps will not prime if the raw water hoses draw air. To prevent damage to ROWPU due to leaves and dirt, DO NOT operate pumps without strainer.

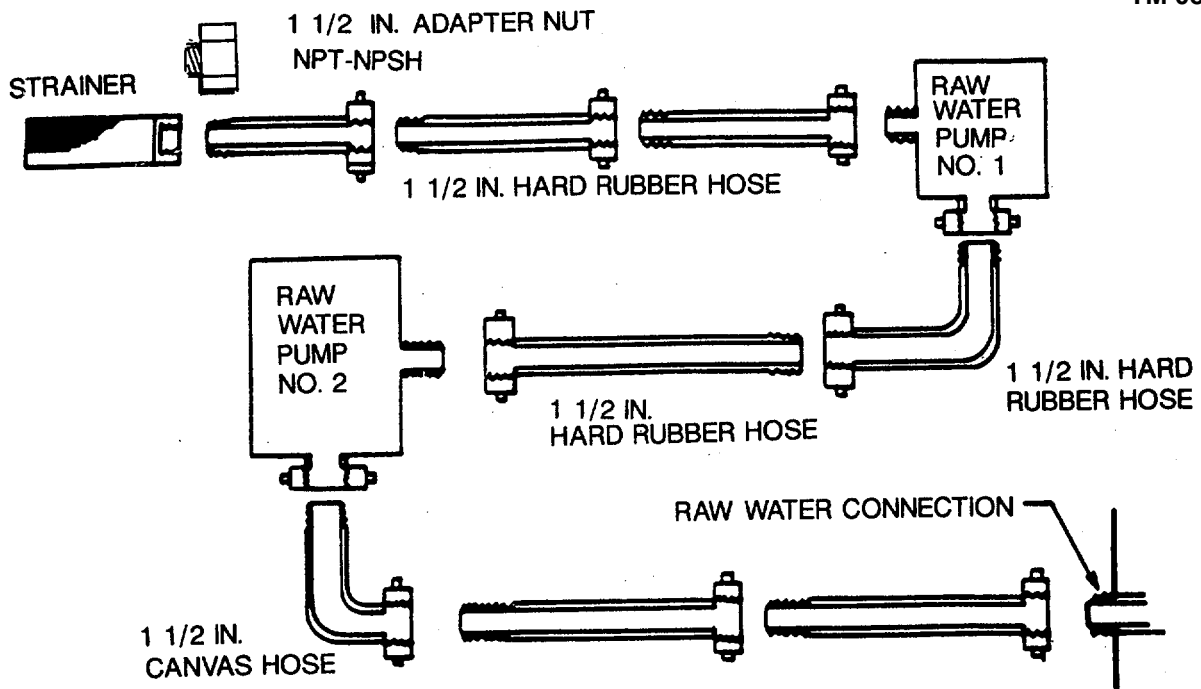

Figure 2-32. Raw Water System

ROWPU

- q. Install the backwash strainer onto the backwash pump frame (fig. 2-33).
- (1) Remove straps securing strainer to backwash pump.
  - (2) Remove the two mounting bolts, nuts, and washers from the backwash strainer bracket.
  - (3) Remove caps from strainer and pump outlets.
  - (4) Attach strainer inlet connection to swivel connector on backwash pump.
  - (5) Place backwash strainer bracket against the frame and line up the holes.
  - (6) Insert two bolts into mounting holes, placing washers and nuts as required.
  - (7) Tighten all connections.

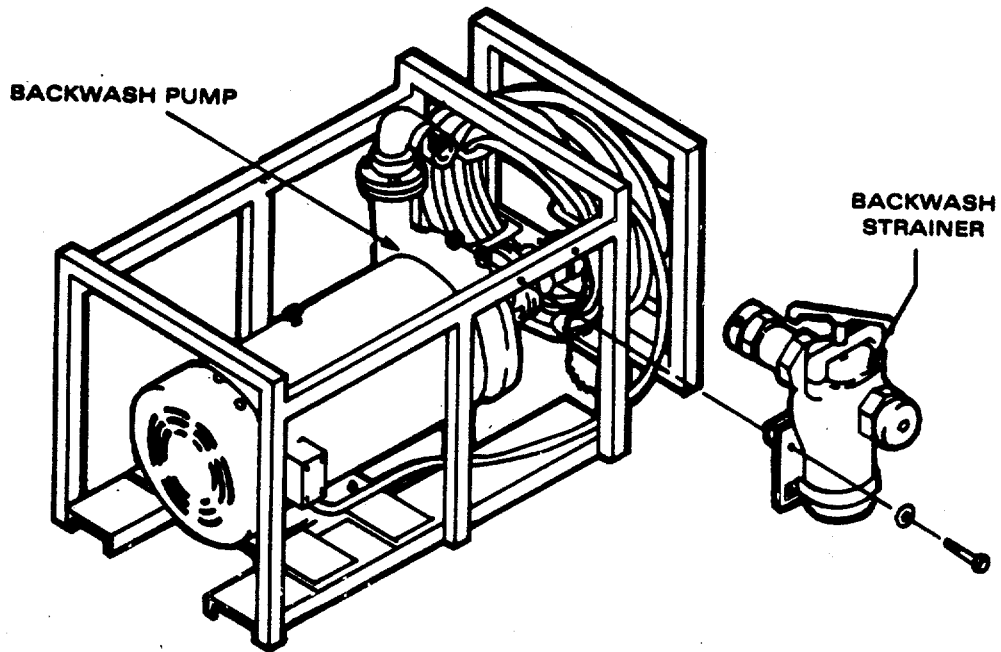

Figure 2-33. Backwash Pump and Strainer

r. (See fig. 2-34) Connect the backwash water tank hose to suction side of backwash pump. Connect backwash water line to discharge side of backwash pump. Start at the ROWPU and work toward the tank in making connections.

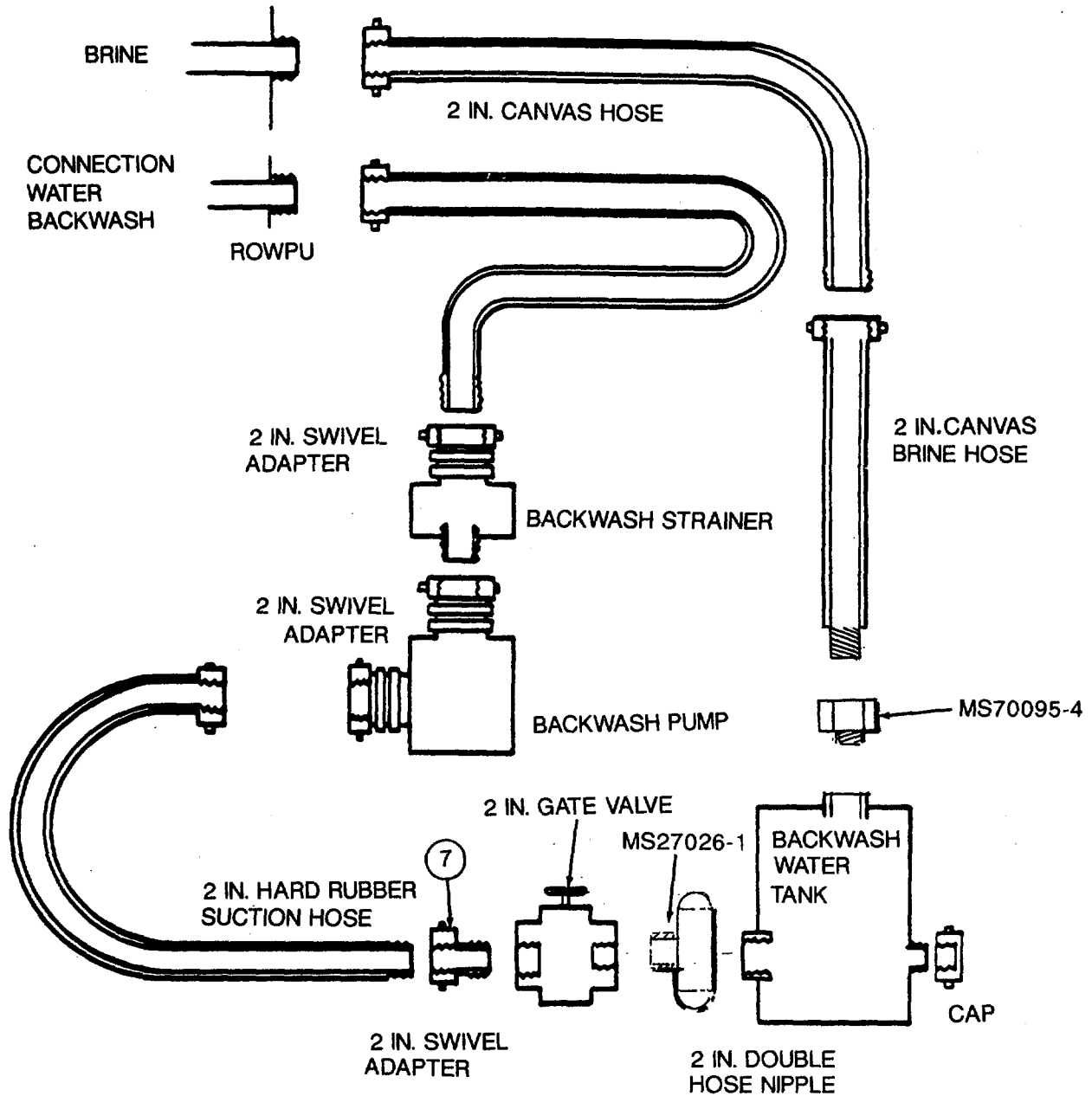

Figure 2-34. Backwash Water System

f

s. Attach product water systems hose (fig. 2-35), working backwards from the distribution nozzle until last connection is made at the ROWPU. Make sure pump drain valve is closed.



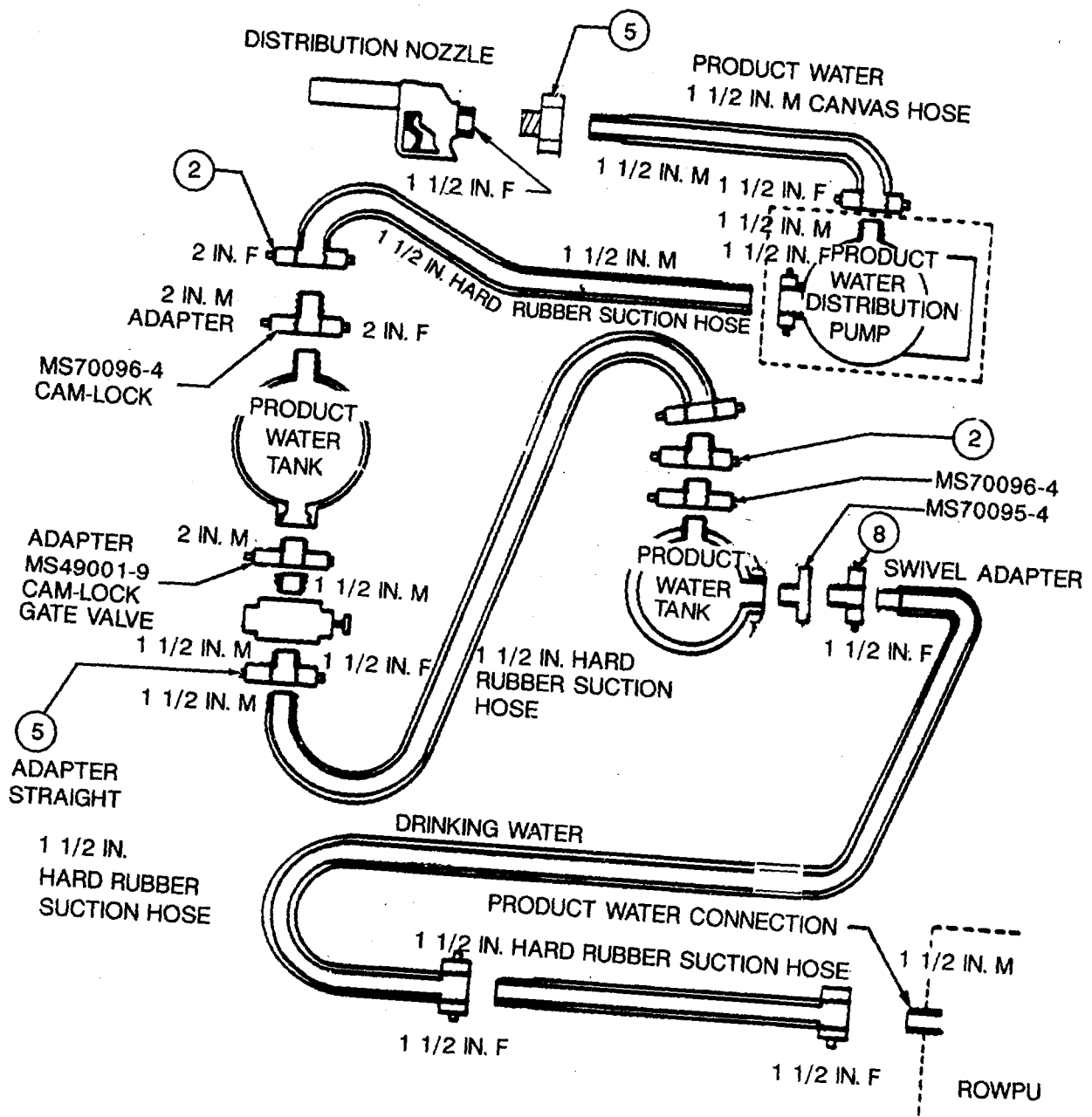

Figure 2-35. Product Water System

t. Hook up waste water and vent vessels systems (fig 2-36). Start at ROWPU with hose going down and away from the ROWPU, ending well downstream of raw water intake.

**CAUTION**

Recheck all hose connections to make sure they are tight.

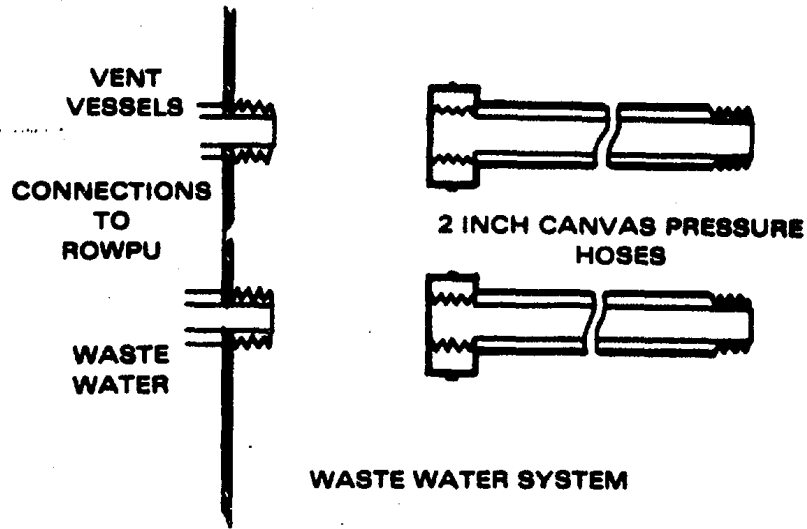

Figure 2-36. Waste Water System

u. Wood Paddles and Chemical Tubes. Open Storage box No. 3 (fig. 2-37) and remove the wood paddles and four sets of chemical tubes.

- (1) Examine tubes for damage and make sure all tubes are secured on the pump and valves.
- (2) Check strainers. They cannot be clogged. Must be tightly fastened to tubes.

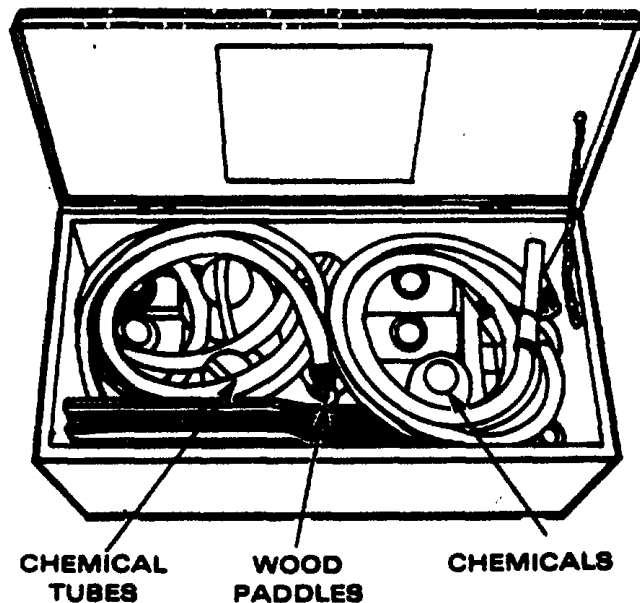

Figure 2-37. Wood Paddles and Chemical Tubes

v. Connect tubes to chemical feed cans as follows:

**CAUTION**

When connecting hoses on chemical feed cans, be careful not to exert any side force on the barb hose fittings; they are easily broken.

- (1) Blue tube to POLYMER can.
- (2) Green tube to SODIUM HEX can.
- (3) Red tube to CHLORINE can.
- (4) Yellow tube to CITRIC ACID can.

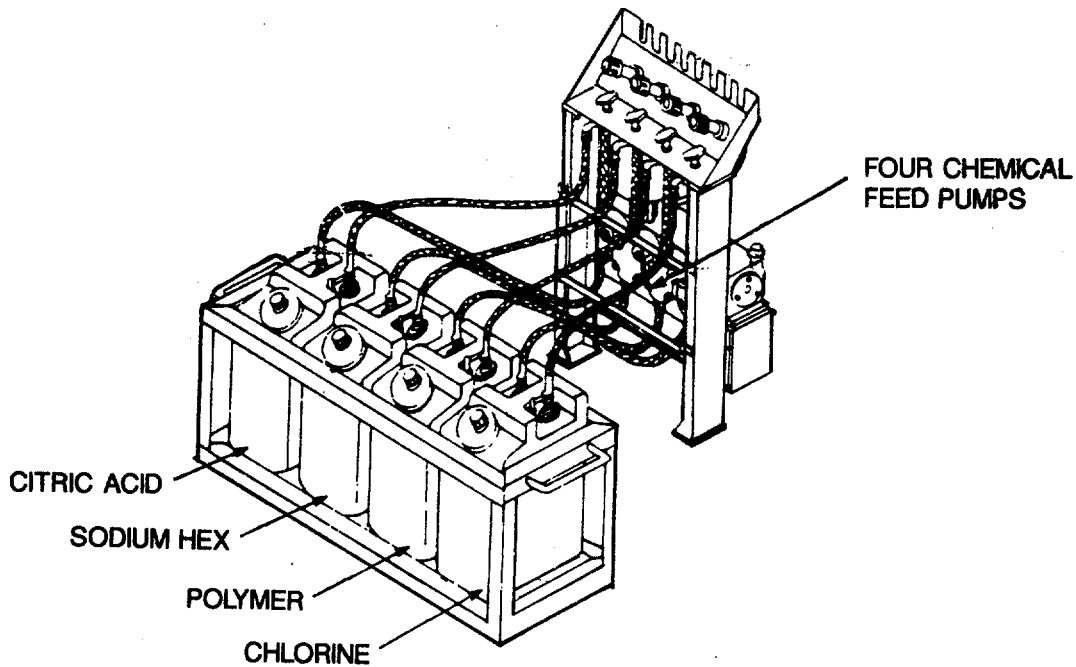

Figure 2-38. Tubes Attached to Chemical Feed Pump

**WARNING**

Chemicals used for operating ROWPU can kill you. The chemicals alone or in mixture can be dangerous. ALWAYS wear protective clothing and make sure area is well ventilated.

**CAUTION**

Use only chlorine-free water for mixing to prevent damage to ROWPU membranes. If this is the first time the ROWPU is being started, use raw water to mix chemicals. If you are restarting the unit, use brine from storage tank.

- w. Mix polymer chemical:

- (1) Fill 107 ml measure HALF-FULL with liquid polymer chemical (there is no half-full mark on measure).
- (2) Pour liquid chemical into POLYMER pail.
- (3) Add brine (if available) or raw water up to the 3-gallon mark.
- (4) Stir with wooden paddle for at least a minute.
- (5) Pour solution into 5-gallon container marked POLYMER.

x. Mix Chlorine Solution:

- (1) Pour 3 gallons of brine into unmarked pail.
- (2) Fill CALCIUM HYPOCHLORITE measure with 0.2 pounds (91 grams) of calcium hypochlorite.

**WARNING**

Mark one pail for chlorine use only. DO NOT use for other chemicals.

- (3) Pour calcium hypochlorite into pail marked CHLORINE.
- (4) Pour brine (if available) or raw water from unmarked pail into CHLORINE pail.
- (5) Stir with wooden paddle for 1 minute.

**NOTE**

Mixing calcium hypochlorite with water produces a chlorine solution. It is normal to see white particles in the solution.

- (6) Pour solution into 5-gallon container marked CHLORINE.

**WARNING**

Make sure all tubing connections are secure on pump, valves, and containers.

y. Mix sodium hexametaphosphate (sodium hex):

- (1) Pour 0.1 pounds (45 grams) of sodium hex into SODIUM HEX measure.
- (2) Put sodium hex into pail marked SODIUM HEX.
- (3) Add brine (if available) or raw water to pail marked SODIUM HEX to the 3-gallon mark.
- (4) Stir with wooden paddle for 1 minute.
- (6) Pour solution into 5 gallon container marked SODIUM HEX.

- z. Mix citric acid:

#### **NOTE**

Perform this step only if ROWPU will be operated 20 or more hours before changing sites. Otherwise, proceed to step aa.

- (1) Pour 0.75 pounds (340 grams) of citric acid into pail marked CITRIC ACID.
- (2) Add brine (if available) or raw water to pail marked CITRIC ACID to the 3-gallon mark.
- (3) Stir with wooden paddle for 1 minute.
- (4) Pour solution into 5-gallon container marked CITRIC ACID.

aa. Check chemical solution levels by pulling level indicators up, and then gently letting go. Indicators should remain raised and read approximately 1/4 full.

ab. Ground the ROWPU with ground rod kept on outside bottom of the control panel (fig. 2-39). First remove the rod with the bolt screwed into the coupler. The bolt keeps from damaging the coupler when the rod is driven into the ground. Drive the first 3-foot section into the ground with the 8-pound hammer, or use the slide hammer.

#### **WARNINGS**

#### **ELECTRICAL HIGH VOLTAGE CAN KILL YOU**

- Electrical high voltage cannot be seen but it can kill you. Electricity is unlike most other dangerous things you can come in contact with because it gives no warning and no symptoms to be wary of. Its effect is immediate. It can kill you, render you unconscious, or severely burn you. To ensure your safety and that of other maintenance personnel, always observe the following precautions:

ALWAYS make sure the unit is properly grounded.

- Take extreme care to prevent injury to fingers or hands when driving the ground rods. Do not place hands between the ram and drive collar. Gloves should be worn. Be sure all connections are tight so as to avoid a possible spark between the units and ground rod.

ac. When the first rod coupler is approximately 6 inches above ground, remove the driving bolt. Screw a new length of ground rod into the one already in the ground and drive it in as with the first section. Continue this process until there are 8 feet of rod in the ground.

When done driving the ground rod, connect the rod sticking out of the earth to the GROUND lug located on the ROWPU frame immediately below the ROWPU electrical cable connections. Use the ground strap provided.

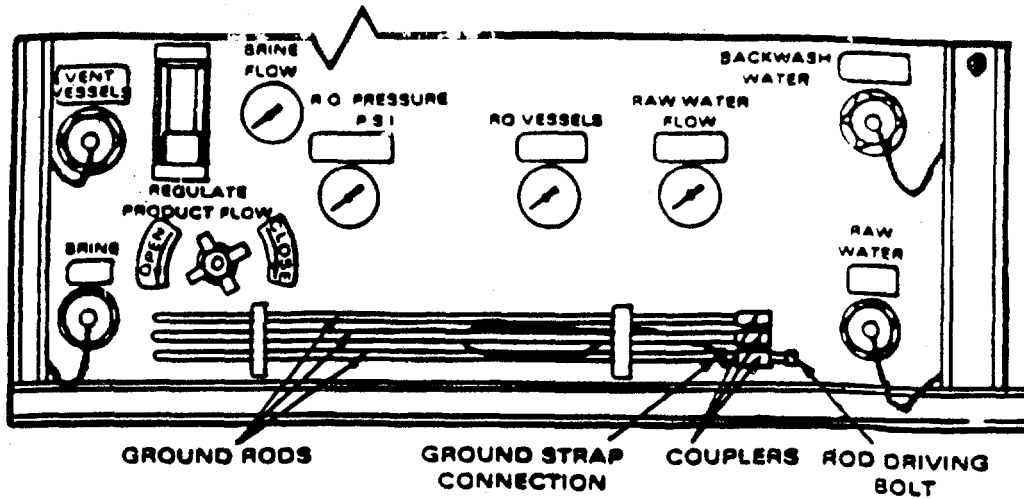

Figure 2-39. Ground Rod In Stowed Position

**NOTE**

If driving gets too hard, soak the earth and try driving rod until 8 feet of rod is in the ground. If this does not work initially, continue alternately soaking ground and driving rod. If unable to get 8 feet of rod into the soil, then keep soil moist around the rod for the duration of the operation.

ad. Unwind the power cables of each pump. Pull the cables to the ROWPU junction box and unscrew the covers of the connectors. Attach pump cables to the connectors shown in fig. 2-40. Plug the power cable from the power source into J1, if not already installed.

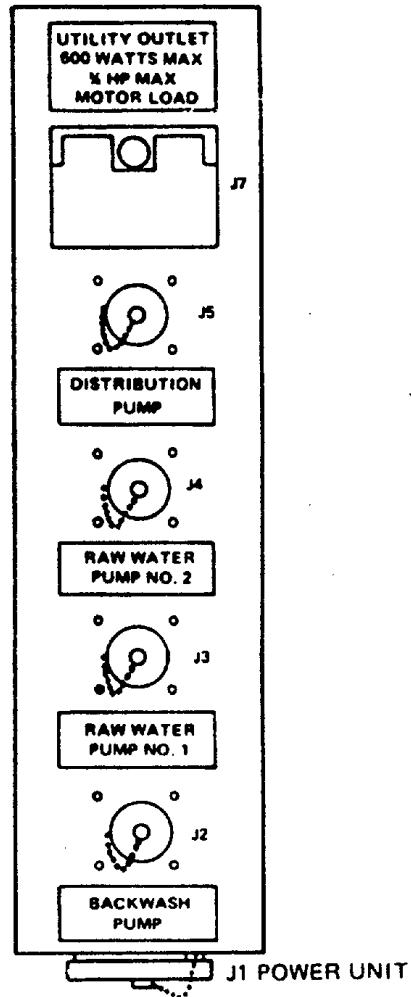

Figure 2-40. Junction Box

**2-23. INITIAL ADJUSTMENTS AND CHECKS.**

- a. Drain Valves. Close all drain valves. Drain valves must remain closed at all times during operation.

**NOTE**

You will find all seven drain valves to the left front of the ROWPU as shown.

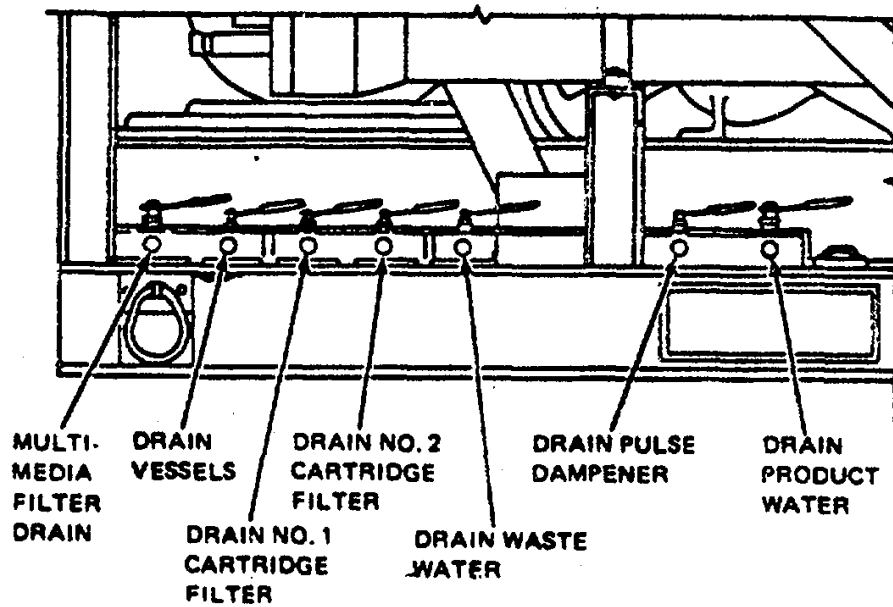

Figure 2-41. Drain Valves (During Operation)

b. Vent Valves. Open all five vent valves as listed below. Three are on the control panel, one is behind the panel and one is to the right of the top R.O. vessel.

1. VENT CARTRIDGE FILTER
2. VENT PULSE DAMPENER
3. VENT MULTIMEDIA FILTER
4. VENT VESSELS (BEHIND PANEL)
5. VENT PRODUCT WATER (see fig. 2-43)

**NOTE**

The fifth vent valve, the VENT PRODUCT WATER valve, is located on top of product water manifold.

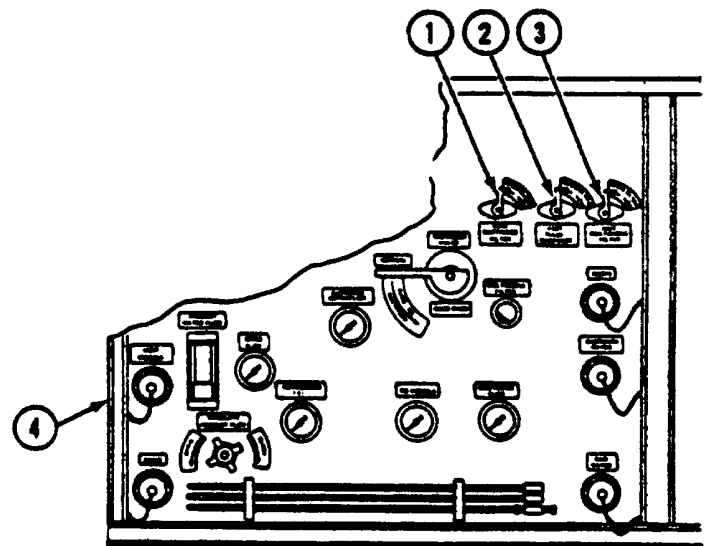

Figure 2-42. Vent Valves



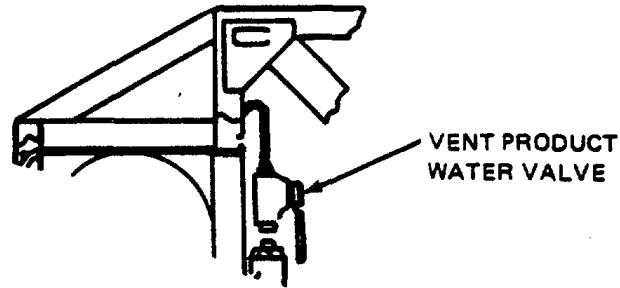

Figure 2-43. Vent Product Water Valve

- c. Backwash Valve. Set the backwash valve to normal.

**NOTE**

Prior to initial water production and after movement to a new worksite, backwash the multimedia filter (para. 2-26).

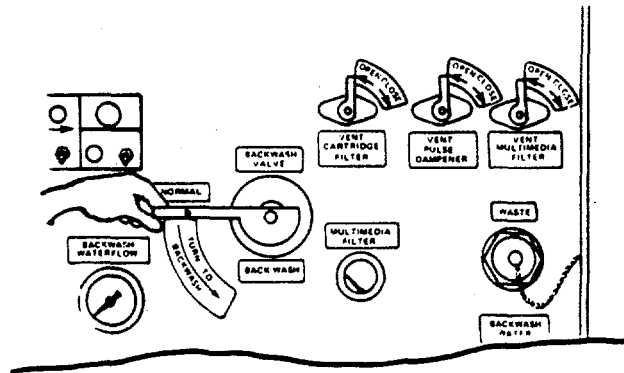

Figure 2-44. Backwash Valve

- d. Regulate Product Flow Valve. Turn the REGULATE PRODUCT FLOW VALVE handle fully counterclockwise to the open position.

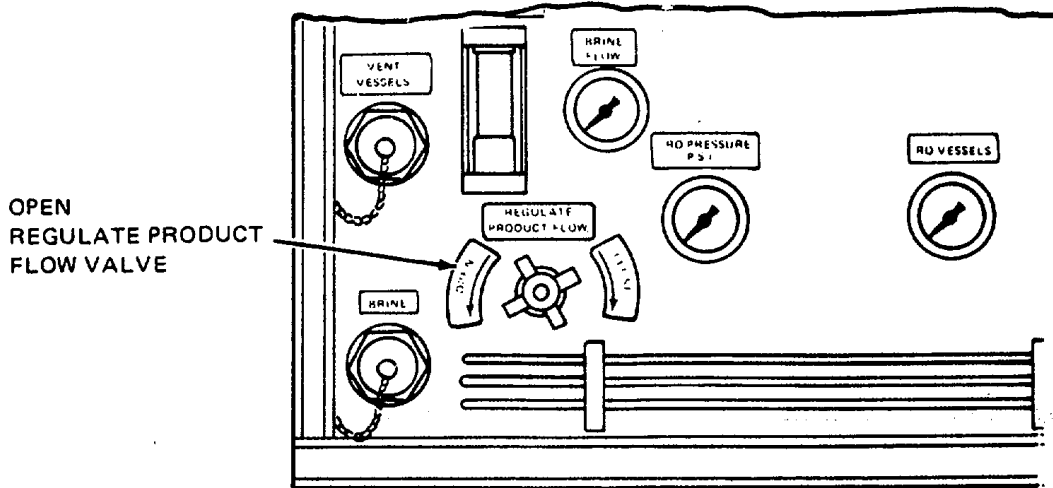

Figure 2-45. Product Flow Valve

e. Control Box Switches.

(1) Check switches in the control box assemblies. If you find any switch in the START or RUN position, set it to STOP or OFF.

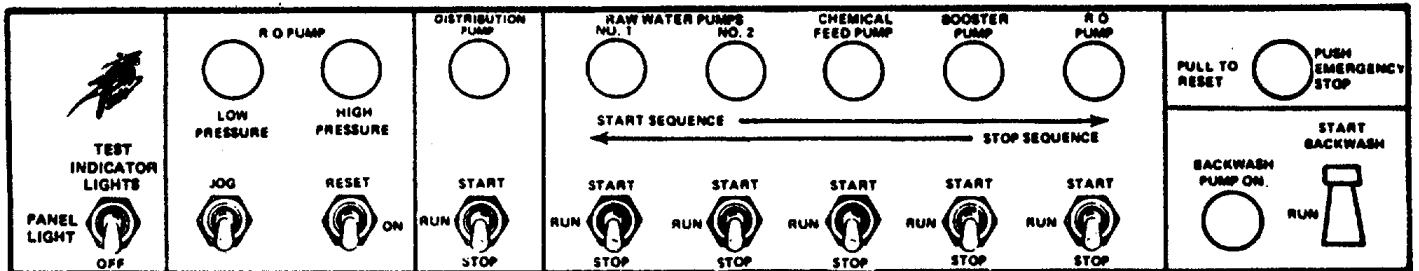

Figure 2-46. Control Box Switches

**NOTE**

The switches marked START are spring loaded. Upon release they return to the middle (RUN) position. The ones marked JOG, RESET, and START BACKWASH return to the normal position when released.

(2) An indicator lamp is associated with each switch except for the EMERGENCY STOP button. Check the setting of the EMERGENCY STOP button. Pull button until it remains out when released. This is the normal operating position.

f. Element cleaning switch. Check that the ELEMENT CLEANING switch is in the OFF position. It should be off at all times except while cleaning R.O. elements (para. 2-29).

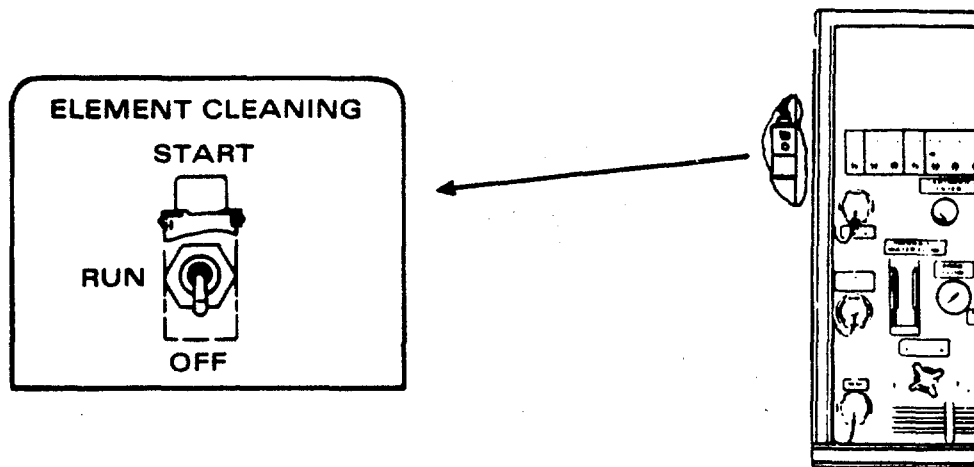

Figure 2-47. Element Cleaning Switch

- g. Chemical Feed Pump Valves. Ensure all valves are in PRIME position (fig. 2-10).
- h. Backwash Timer. Press RESET button on subpanel to ensure pilot controller valve is in SERVICE position (para. 2-26b (2)).
- i. Take an unmarked pail and an adjustable wrench to the source of water. Check suction hoses in raw water to make sure strainer is under water. With the pail, draw some raw water from the source. Take it to raw water pump No. 1.

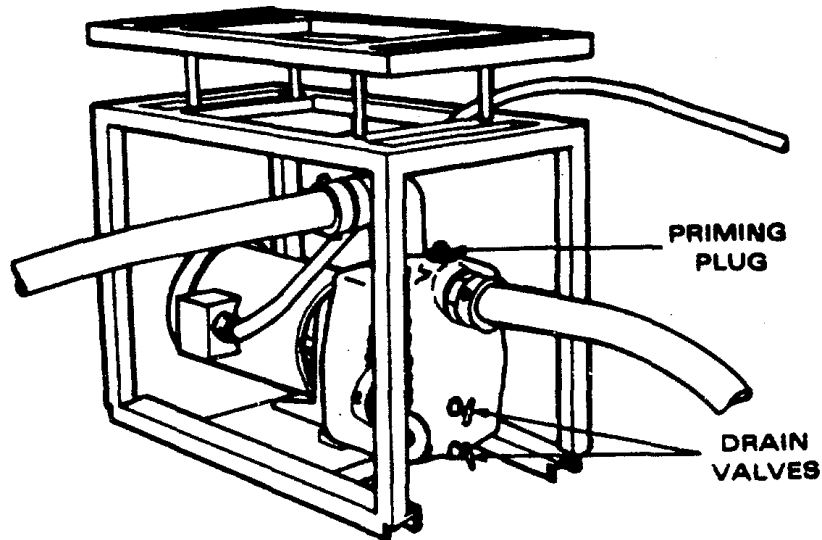

Figure 2-48. Raw Water Pump (Prime and Drain)

- j. Check drain valves (petcocks) on the pump. If open, close them. Remove priming plug with your wrench. Fill pump with raw water. Screw priming plug back into pump. Return adjustable wrench to tool case.

**2-24. SAFETY VALVES.** The ROWPU has three automatic safety devices: the high-pressure relief valve, the high-pressure switch, and the rupture disc assembly.

a. The HIGH PRESSURE RELIEF VALVE is located just behind the PULSE DAMPENER VALVE. If R.O. pressure goes above 1100 psi, this valve opens automatically and discharges water through a pipe at the back of the ROWPU. If this valve activates (indicated by sudden pressure loss), immediately press the PUSH EMERGENCY STOP switch. Open REGULATE PRODUCT FLOW VALVE after unit is shut down. When the pressure drops below 1100 psi, the valve will close automatically.

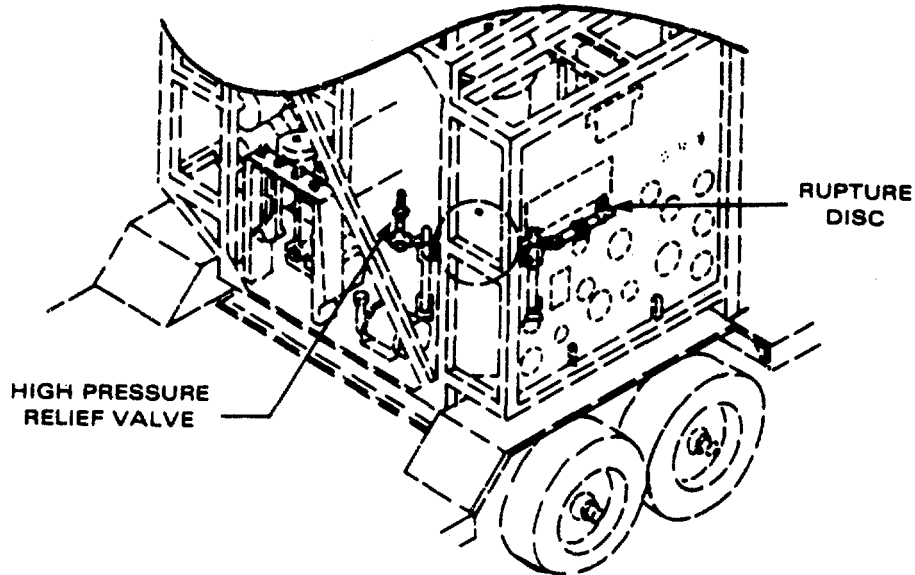

Figure 2-49. High Pressure Relief Valve and Rupture Disc

**CAUTION**

If the valve does not close automatically, notify unit maintenance and do not try to restart the ROWPU.

After the HIGH PRESSURE RELIEF VALVE closes, clean the R.O. elements (see para. 2-28) and start the ROWPU in the normal manner (para. 2-25).

b. The HIGH PRESSURE SWITCH is mounted to the rear of the front panel adjacent to the PANEL LIGHT. The HIGH PRESSURE SWITCH activates above 1250 psi. If the HIGH PRESSURE SWITCH activates, the R.O. pump will automatically shut down and the HIGH PRESSURE LAMP (blue) will come on. When the pressure drops, use the RESET SWITCH to reset high pressure switch. Notify unit maintenance to troubleshoot the HIGH PRESSURE RELIEF VALVE.

c. The RUPTURE DISC ASSEMBLY is located on the pipe between the R.O. PUMP and the PULSE DAMPENER. The rupture disc is a thin sheet of metal that tears when the pressure goes above 1425 psi. Water is then discharged through the six holes in the top of the assembly. Because the water is under such high pressure, it will make a lot of noise, and water will be sprayed on the inside of the ROWPU. If the RUPTURE DISC ASSEMBLY ever activates, press the PUSH EMERGENCY STOP switch and open the REGULATE PRODUCT FLOW valve. When the pressure has dropped, replace the RUPTURE DISC (see para. 3-7) and clean the R.O. elements (see para. 2-28). Also

notify unit maintenance to troubleshoot the HIGH PRESSURE RELIEF VALVE and the HIGH PRESSURE SWITCH.

**2-25. OPERATING PROCEDURES.**

- a. Apply power to the ROWPU.

**NOTE**

The blue lamp, R.O. PUMP LOW PRESSURE, on ROWPU control box assembly comes on as soon as power is applied to the ROWPU.

- b. Push EMERGENCY STOP button in if any of the following conditions exist:

**WARNING**

Operating personnel could be injured or the equipment could be damaged if operation of the ROWPU is allowed to continue.

- (1) Blue HIGH PRESSURE lamp associated with R.O. PUMP comes on but R.O. Pump does not automatically stop.
- (2) Blue LOW PRESSURE lamp associated with R.O. PUMP comes on but R.O. Pump does not automatically stop.
- (3) Some other serious trouble (malfunction) indicated by noise, vibration, large water leaks, etc.

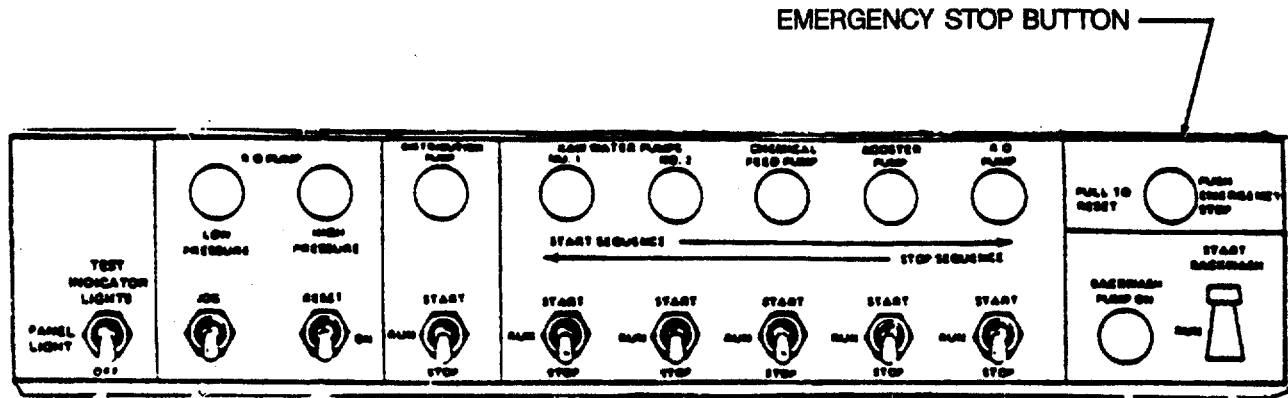

Figure 2-50. Emergency Stop Button

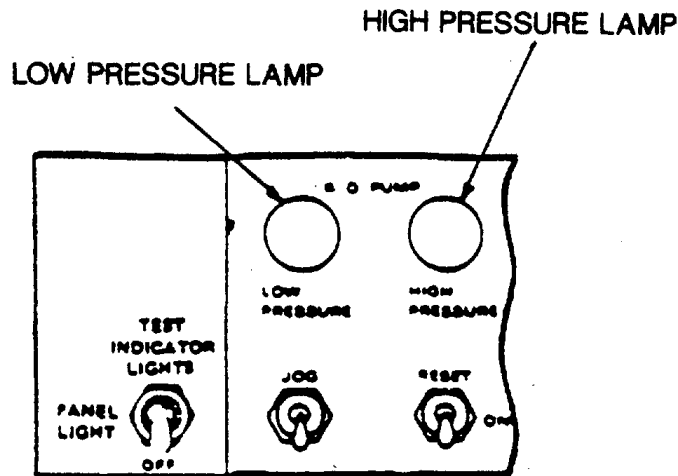

Figure 2-51. High/Low Pressure Lamps

**NOTE**

If low or high-pressure switches shut down the ROWPU automatically, they can only be reset with the RESET switch. After emergency shutdown, distribution of drinking water can still be made by pulling out the EMERGENCY STOP button and running the distribution pump as required.

- c. Go to control box assembly on the ROWPU. Locate the two lamps and switches for RAW WATER PUMPS.

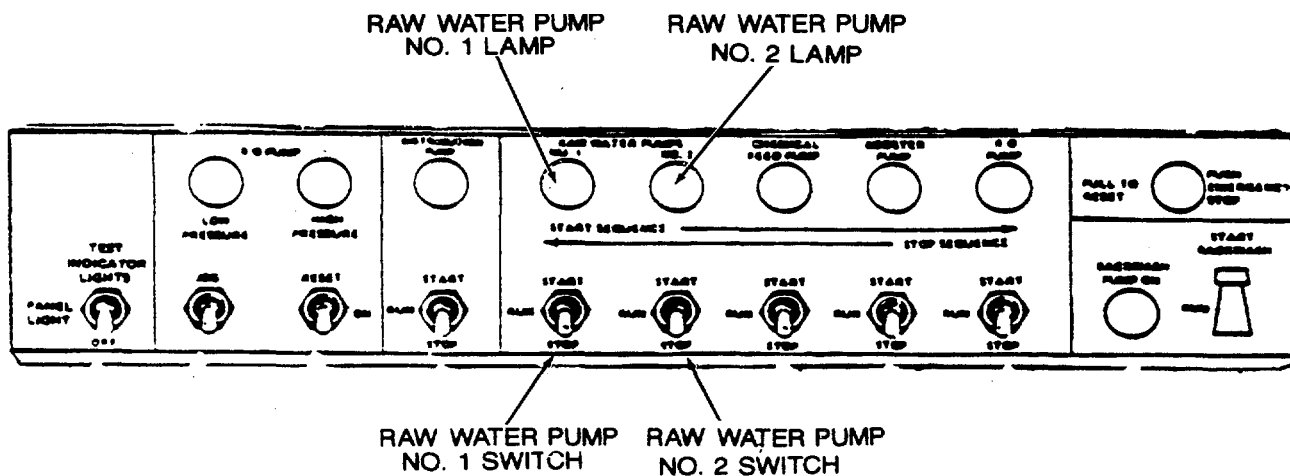

Figure 2-52. Switches (Pump Controls)

- d. Start RAW WATER PUMP NO. 1.
  - (1) Set switch upward to START.
  - (2) Hold switch up until green lamp No. 1 comes on.
  - (3) Release switch.
  - (4) Switch will return to RUN.

(5) Look at output hose from raw water pump No. 1. Hose goes into input connection of raw water pump No. 2. Hose should expand and straighten out.

e. Start RAW WATER PUMP NO. 2.

- (1) Set switch upward to START.
- (2) Hold switch until blue lamp No. 2 comes on.
- (3) Release switch.
- (4) Switch will return to RUN

(5) Look at output hose from raw water pump No. 2. Hose goes into lower right connection of ROWPU control panel. Hose should expand and straighten out.

- (6) Check RAW WATER FLOW gage for 27-33 gpm.

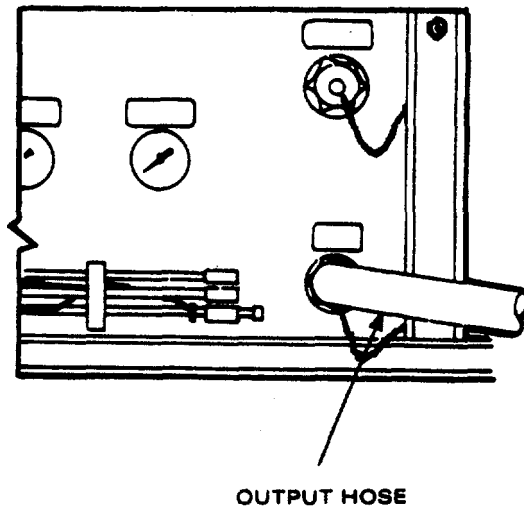

Figure 2-53. Output Hose - Raw Water Pump No. 2

**CAUTION**

Pump valves should not be in OFF position at any time during chemical feed pump operation.

**NOTE**

If blue lamp, R.O. PUMP LOW PRESSURE, on control box assembly, stays on, then priming did not work. Set both RAW WATER PUMP switches to STOP. Prime raw water pump No. 1 again (as described above), then restart both pumps. Repeat priming if necessary until water starts flowing into the ROWPU.

f. On the control box assembly is a lamp labeled CHEMICAL FEED PUMP. Below the lamp is a switch. Hold switch at START until blue lamp above it goes on. Release switch. Switch returns to RUN.

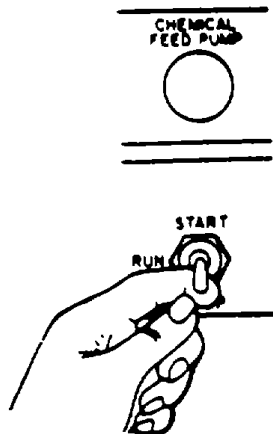

Figure 2-54. Chemical Feed Pump Start Switch

- g. Ensure all four chemical feed control knobs are set to their maximum settings: 8.5.
- h. With the control knobs set at maximum, allow chemical pump motor to run with valve set to PRIME until no more air bubbles are seen in the solution flowing in the polymer tubes.

**NOTE**

If pump fails to prime, there may be some particles in the suction or discharge valves. Check Section II, Chapter 3, Troubleshooting.

- i. When you can't see any more bubbles in either tube, calibrate the POLYMER flow as follows:
  - (1) For noticeably turbid (dirty or murky) source water, set POLYMER control knob to 2.6. Otherwise, set control knob to 1.0.
  - (2) Use the 100-ml graduated plastic cylinder out of Storage Box No. 3.
  - (3) While POLYMER pump is running, remove polymer return quick disconnect from the container and catch flow for 1 minute.
  - (4) If knob was set to 2.6, flow should be about 60 ml/min. Adjust knob to obtain correct flow. Record knob setting for future reference.



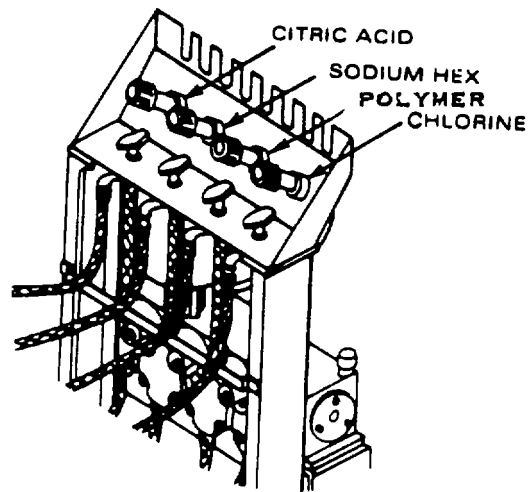

Figure 2-55. Control Knobs

- j. When no more bubbles can be seen in SODIUM HEX and CHLORINE hoses, calibrate the flow as follows:
- (1) Set the SODIUM HEX control knob to 2.6.
  - (2) Remove return quick disconnect from chemical container.
  - (3) Catch chemical in 100 ml graduated cylinder (Storage Box No. 3)
  - (4) Adjust control knob until you get 60 ml/min. flow and record setting for future reference.
  - (5) Calibrate chlorine flow in same way.
  - (6) Do NOT yet turn valves to RUN; leave them in PRIME position.

k. Leave CITRIC ACID control knob at maximum setting; no calibration is required for CITRIC ACID flow. Valve remains in PRIME position throughout normal operation.

l. With both raw water pumps working, and the chemical feed pump running, set POLYMER pump valve from PRIME to RUN. Set VENT MULTIMEDIA FILTER valve to CLOSE as soon as a full stream of water flows out of vent pipe (located at bottom right-hand front of trailer, below R.O. pump belt guard).

#### NOTE

There should be air venting out of the pipe as the multimedia filter fills, followed by a steady stream of water when the filter is full. If not, the vent line is probably blocked by a small piece of filter media. Remove vent line from filter and blow compressed air through the line to dislodge the blockage.

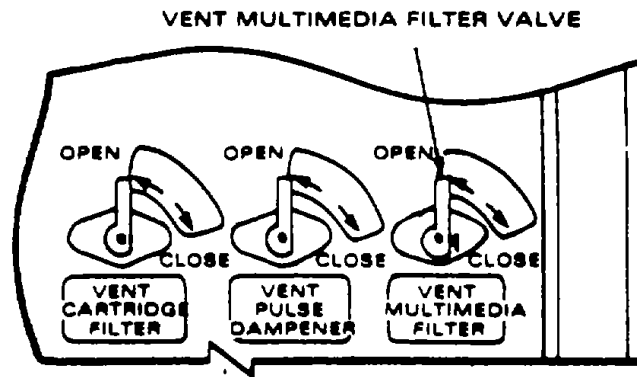

Figure 2-56. Multimedia Filter Vent Valve

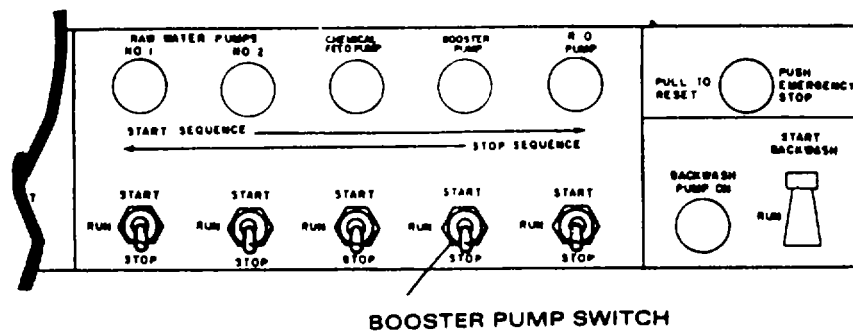

Figure 2-57. Booster Pump Switch

m. Start booster pump.

- (1) Set BOOSTER PUMP switch upward to START.
- (2) When blue lamp comes on, release switch.
- (3) Switch will return to RUN.
- (4) Set VENT CARTRIDGE FILTER valve to CLOSE as soon as a full stream of water flows out of vent pipe (located at bottom right-hand corner of the frame below R.O. pump screen belt guard).

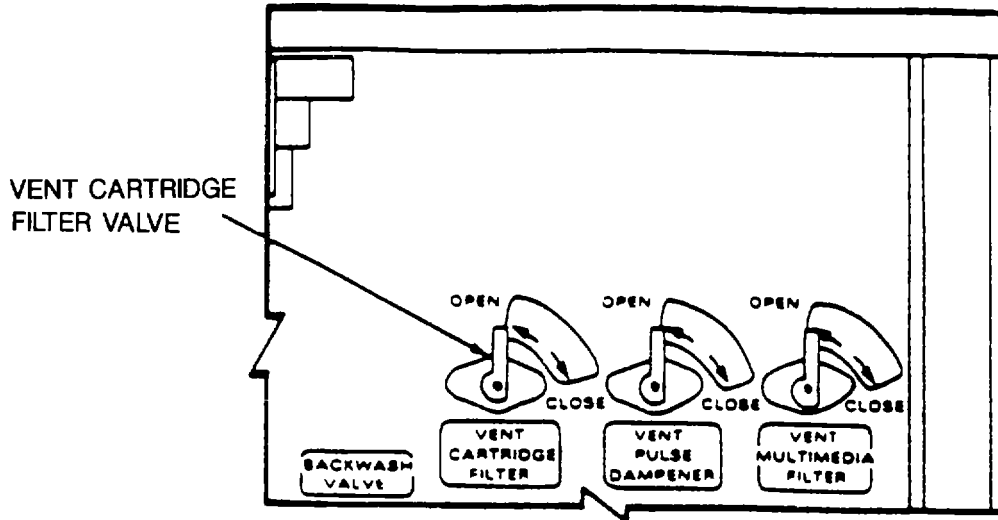

Figure 2-58. Cartridge Filter Vent Valve

R. O. PUMP LOW PRESSURE LAMP

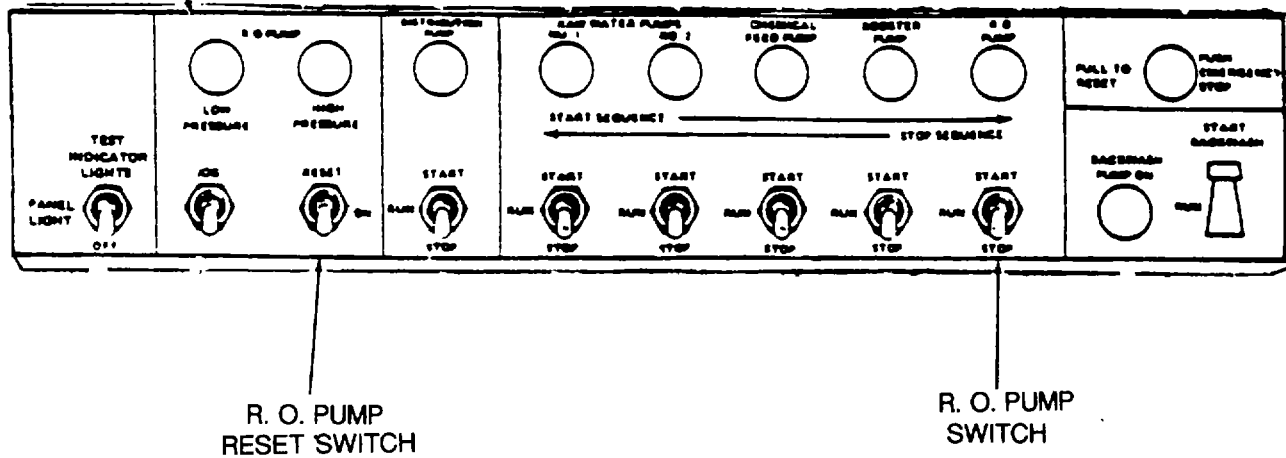

Figure 2-59. Controls, R.O. Pump

- n. Start R.O. pump:
- (1) Make sure VENT PULSE DAMPENER (fig. 2-61) is open.
  - (2) Set R.O. Pump RESET switch upward. R.O. pump LOW PRESSURE lamp goes OFF and switch returns to ON.
  - (3) Hold R.O. PUMP switch upward to START.
  - (4) As soon as R.O. PUMP blue lamp comes on, release switch.
  - (5) Switch will return to RUN.

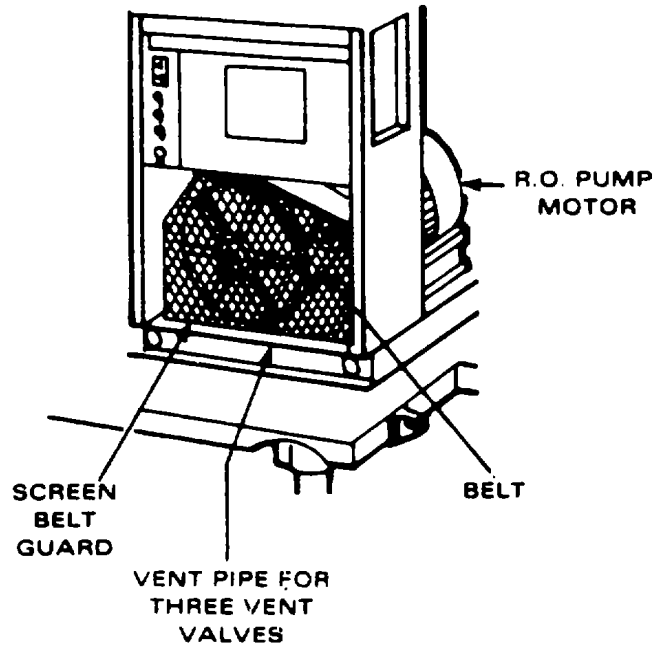

Figure 2-60. R.O. Pump And Motor

(6) Set the VENT PULSE DAMPENER valve to CLOSE as soon as you see a full stream of water coming from the vent (located at the bottom right hand side of the unit below the R.O. pump screen belt guard).

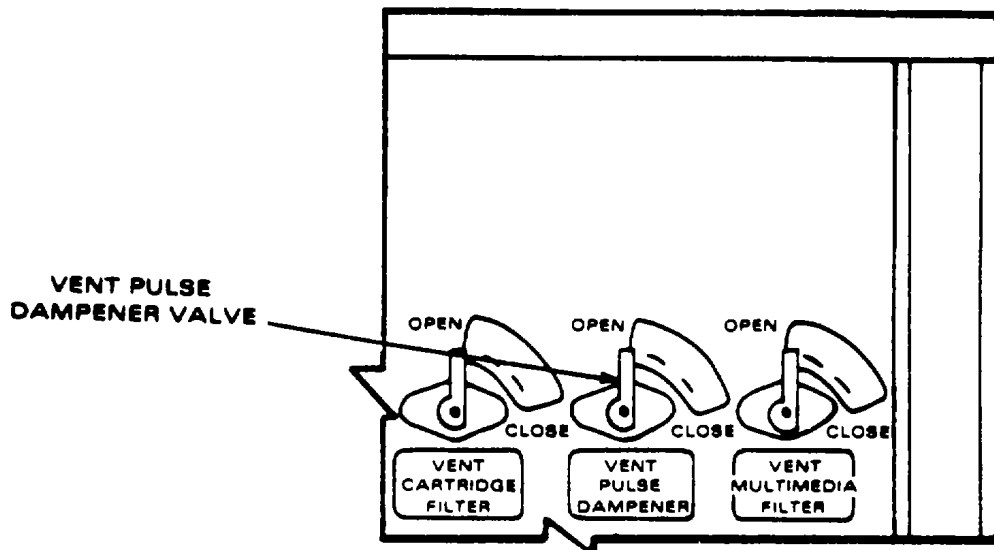
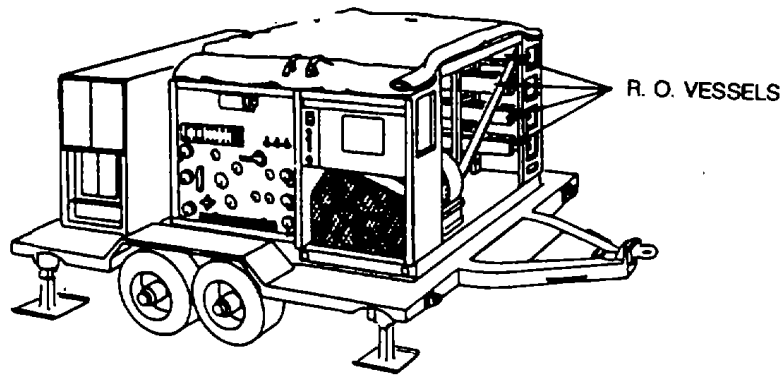

Figure 2-61. Pulse Dampener Vent Valve

**NOTE**

The filtered water is bypassing the R.O. vessels.



**Marine Corps unit is skid mounted.**

*Figure 2-62. R.O. Vessel*

o. Observe the VENT VESSELS hose for water flow and clarity. Note that the water coming out of VENT VESSELS water hose is getting clearer and clearer. Within 10 minutes, water should be clear. As soon as water appears completely clean, proceed to step p.

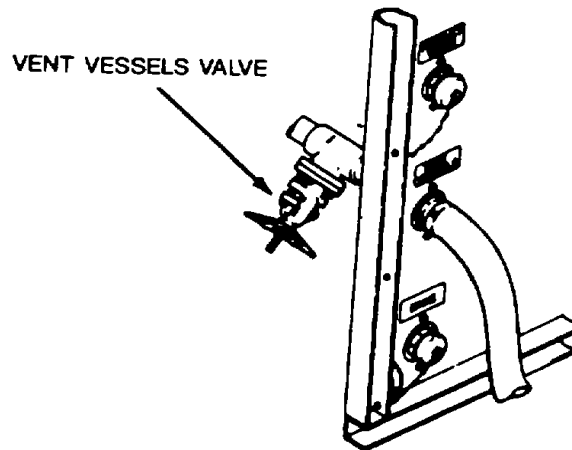

*Figure 2-63. Vent Vessels Valve*

**WARNING**

Vent vessels water flow is not potable. Run water downstream from raw water source as far away as possible.

p. Examine filtered water for clarity:

(1) From Storage Box No. 3, get the plastic graduated cylinder (called turbidity tube) used for checking clarity of water.

- (2) Bottom of turbidity tube has a white bullseye set in a black background disc.
- (3) Go to left front side of ROWPU and observe the seven drain valves.

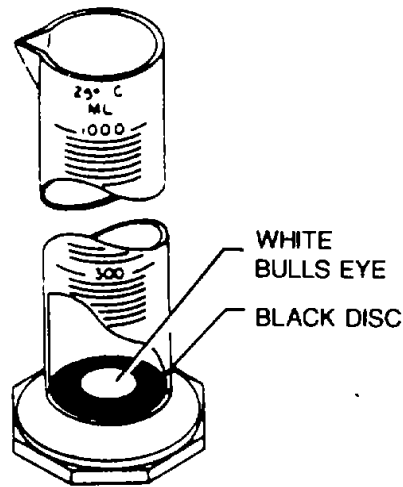

Figure 2-64. Turbidity Tube

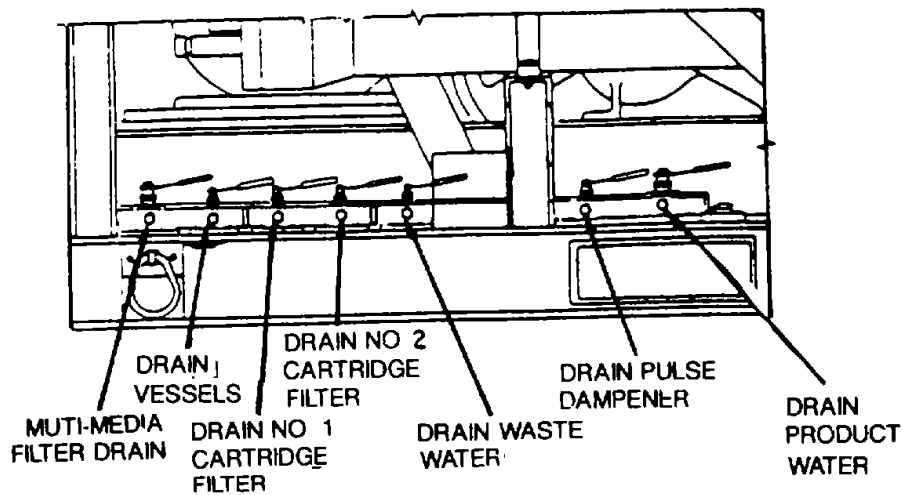

Figure 2-65. Drain Valves

- (4) Draw a sample of 600 milliliters of water from DRAIN NO. 1 CARTRIDGE FILTER into the turbidity tube.
- (5) Look down into turbidity tube and you should be able to see both the white bullseye and black disc at the bottom of the tube clearly. If they can be seen clearly, proceed to step q.
- (6) If both cannot be seen clearly, run the ROWPU another 10 minutes. Repeat steps (4) and (5).
- (7) If after second sampling test, water is not clear, readjust POLYMER chemical feed control knob setting by 0.5.

**NOTE**

The setting of 60 or 20 ml/min set earlier was only to prevent overdosing of polymer. This rate may be adjusted during operation to improve clarity.

- (8) Run ROWPU for 5 minutes, and repeat steps (4) and (5). If both bullseye and black disc can be seen clearly, proceed to step r; if not, proceed to step (9).
- (9) Increase control knob setting by 0.5.
- (10) Repeat steps (8) and (9) until water is clear.

**NOTE**

Unless source water is noticeably turbid, it should not be necessary to increase POLYMER setting beyond 2.5.

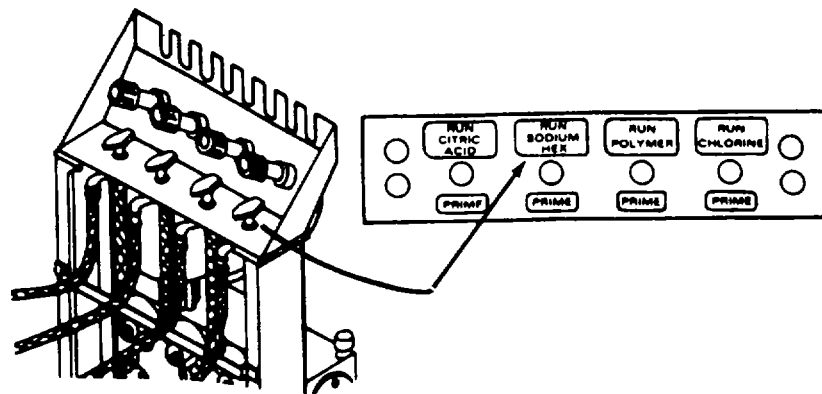

Figure 2-66. Nameplates

- q. Set SODIUM HEX valve to RUN position (fig. 2-66).
- r. Check that the vent product water valve (fig. 2-6) is in the OPEN position. The vent product water valve allows air to escape from the product water line and lowers product water pressure. It should be closed once product water has been produced.
- s. Check that the REGULATE PRODUCT flow valve (3, fig. 2-67) is fully open.

**NOTE**

You are now ready for full operation under normal circumstances. A few more adjustments are required while you produce water and store it in tanks for future use.

- t. Slowly close VENT VESSELS valve located behind VENT VESSELS outlet. This allows filtered water to enter R.O. vessels.

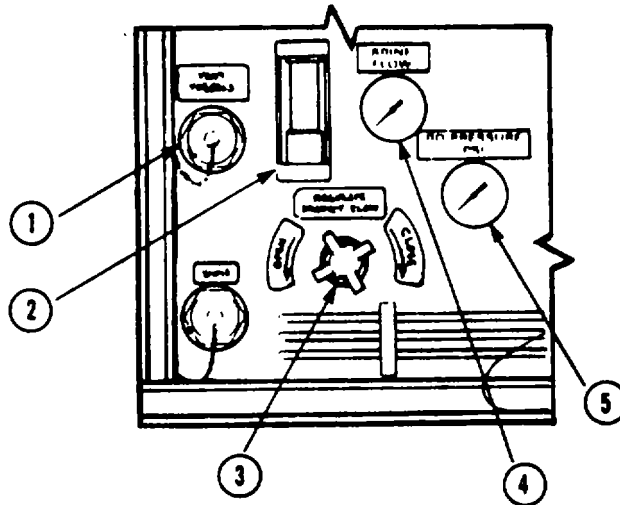

Figure 2-67. R.O. Pressure and Product Water Flow Gages

u. Slowly adjust REGULATE PRODUCT FLOW valve (3) to the right. Watch for an increase in PRODUCT WATER FLOW gage (2), a decreased flow in BRINE FLOW gage (4), and increased pressure in the R.O. PRESSURE PSI gage (5).

**CAUTION**

PRODUCT WATER FLOW should not exceed 12 gpm for seawater conditions, 16 gpm for fresh or brackish water. R.O. PRESSURE PSI gage should not exceed 960 psi (seawater), 500 (fresh or brackish water). If gage readings exceed these limits, refer to Section II, Chapter 3, Troubleshooting.

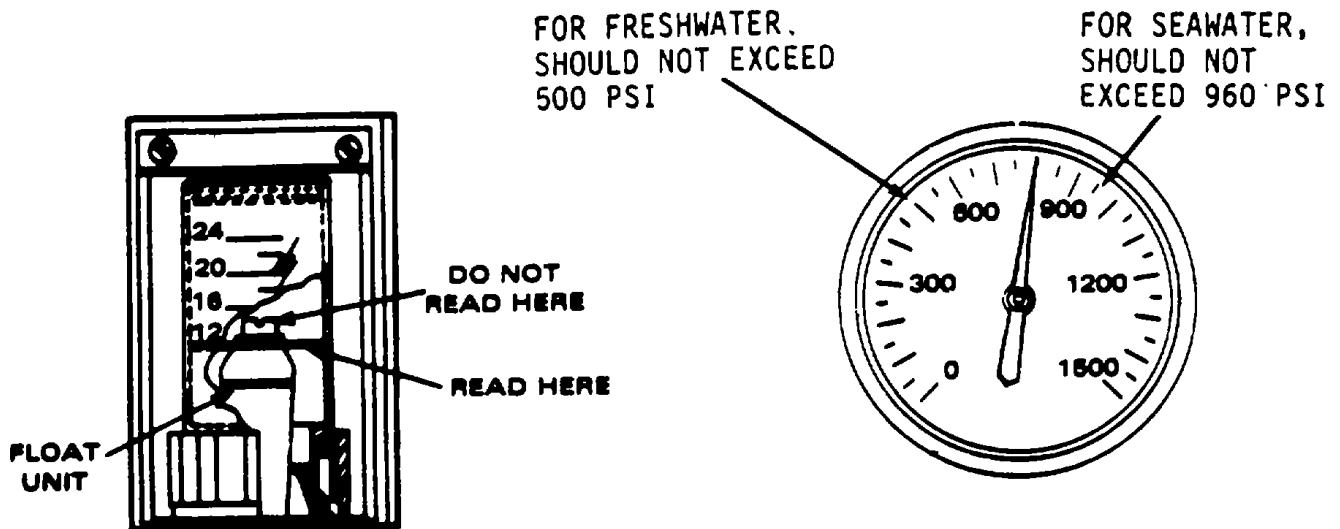

Figure 2-68. Product Water Flow Gages And Pressure

v. Close REGULATE PRODUCT FLOW valve very slowly. Watch gages until you obtain proper balance shown in Table 2-4.



w. Set CHLORINE valve to RUN position (fig. 2-66).

x. The ROWPU is now in full operation. Check the TDS of the product water (para. 2-32c), record the findings in operator's log. If reading is above 1500 ppm, refer to Section II, Chapter 3, Troubleshooting. Keep watching your gages and lamps. Complete the operator's record (log) hourly. Refer to Table 2-4 for normal and trouble point indications.

y. Periodically check the brine tank.

(1) Covered?

(2) Full? Up to 3 inches from top?

(3) When brine tank is full, remove the canvas brine hose coming from the ROWPU and allow to drain on the ground.

**WARNING**

Ensure that the drained brine water runs towards lower ground as far from the raw water source as possible.

(4) Let brine flow on the ground until after next backwash, then put the hose back into tank.

Table 2-4. Gage Readings, Normal and Trouble-point

Gage/Indicator	Normal Reading	Trouble point reading
CARTRIDGE FILTER	1 to 20 psid	Over 20 psid
MULTIMEDIA FILTER	0 to 10 psid	Either over 10 psid or not within 5 psid of log reading at startup
RAW WATER FLOW	27 to 33 gpm	Drop to 25 gpm or less
BRINE FLOW	16 to 24 gpm	Below 15 gpm
PRODUCT WATER FLOW:		
SALT WATER	6 to 12 gpm	Above 12 gpm
FRESH WATER	Up to 16 gpm	Above 16 gpm
BRACKISH WATER	Up to 16 gpm	Above 16 gpm
R.O. PRESSURE PSI:		
SALT WATER	Not to exceed 960 psig	Above 960 psig
FRESH WATER	Not to exceed 500 psig	Above 500 psig
R.O. VESSELS	50 to 100 psid	Above 100 psid
TDS OF PRODUCT WATER	Below 1500 ppm	Above 1500 ppm

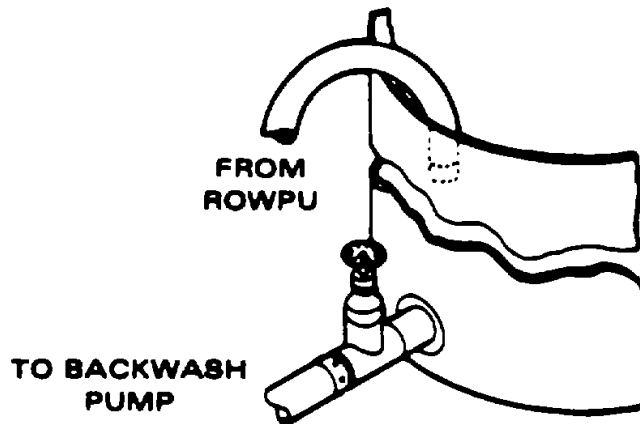

Figure 2-69. Brine Water Shutoff Valve

**NOTE**

The R.O. VESSELS gage is a good indicator of the condition of the R.O. elements. Gage should read about 85 psid while R.O. elements are in good condition.

z. Check R.O. PUMP LOW PRESSURE lamp in the upper left corner of control box assembly. It must be off while ROWPU is operating normally. If the blue lamp comes on, check Table 3-2 for troubleshooting procedures.

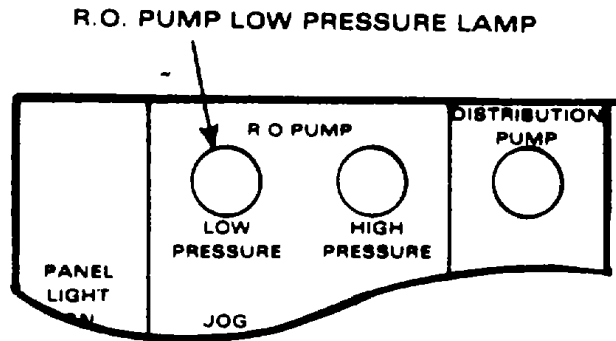

Figure 2-70. R.O. Pump Low Pressure Lamp

aa. Check R.O. PUMP HIGH PRESSURE lamp in upper left of control box assembly. It must be off at all times while ROWPU is operating normally. If that blue lamp ever comes on, the R.O. pump will shut down at once. (Other pumps will continue to run.) Check Table 3-2 for troubleshooting procedures.

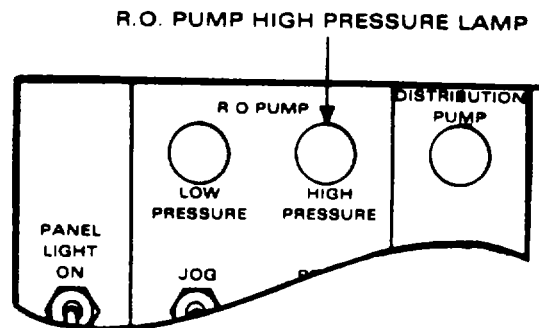

Figure 2-71. R.O. Pump High Pressure Lamp

ab. Watch water level in product water tanks.

- (1) Keep tanks covered.
- (2) To distribute water, start distribution pump.

ac. To start distribution pump.

- (1) Set DISTRIBUTION PUMP switch on control box assembly panel to START.
- (2) Green lamp comes on.
- (3) Run distribution pump until user has enough, then switch to STOP.

(4) If product water tank is full, stop ROWPU until more water is needed. (See para. 2-31 for normal shutdown procedure.)

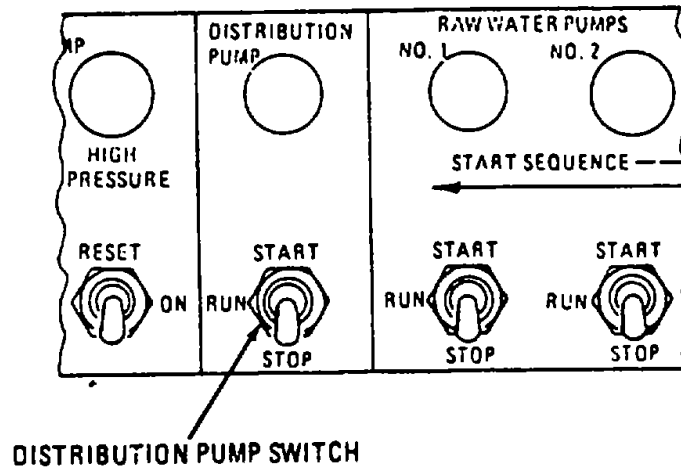

Figure 2-72. Distribution Pump Switch

## 2-26. BACKWASH OF MULTIMEDIA FILTER

### NOTE

The multimedia filter should be backwashed:

- After 20 hours of ROWPU operation, or
- Multimedia filter gage reading is over 10 psid, or
- Multimedia filter gage reading exceeds 5 psid of log reading at startup, or
- ROWPU is to be shut down.

a. General. The backwash cycle is an up-flow operation. Water flows from the bottom to the top of the tank and then out to drain through the backwash flow control, washing out turbidity and settling the filter bed. The filter has three separate backwash stages. The first stage of backwash is at 70 gpm to fluidize the bed. A second backwash stage begins at approximately 120 gpm, tumbles at the bed, and scours the particles against one another when the backwash diaphragm valve opens. The backwash diaphragm valve then closes, returning the backwash rate to 70 gpm to restratify the media bed. The rinse cycle is a down flow operation. Water flows from the top of the tank through the filter bed and out to drain. This displaces the backwash water in the tank, and preconditions the filter bed before the filter reaches the purge cycle. The purge cycle is rapid downflow rinse to remove turbidity from the bottom of the filter and recondition the filter bed prior to the return to service.

b. Backwash Timer and Multimedia Filter Control Valve (fig. 2-15). The direction and rate of water flow through the multimedia filter are controlled by the control valve and backwash diaphragm valve. The control valve consists of six diaphragms which open and close during the timer cycles of backwash, conditioned rinse, and service (service means normal ROWPU operation). As the backwash timer automatically changes cycles, its pilot valve changes position. When the backwash timer pilot valve changes position, it hydraulically closes and opens the diaphragms in the control valve. During the 120 gpm portion of the backwash cycle (referred to as "secondary backwash") the backwash timer solenoid valve sends water to the backwash diaphragm valve (located just under the control valve). This opens the backwash diaphragm valve, resulting in the higher rate of backwash water flow.

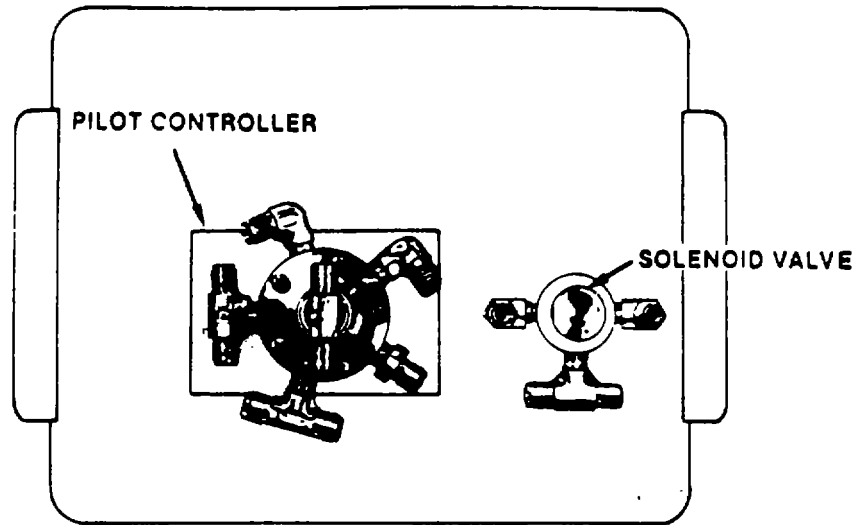

Figure 2-73. Solid-State Timer (Pilot Control Valve)

Solid-State Timer. The solid state timer is approximately 8 inches high, 10 inches wide and 6 inches deep. Protruding from the rear of the timer is the pilot controller and solenoid valve (fig. 2-70). Inside is a black RESET button and an INTERNAL INDICATOR knob mounted to a subpanel (view 1, fig. 2-71).

(1) Ensure INTERNAL INDICATOR knob is in the SERVICE position by pressing the black RESET button. The INTERNAL INDICATOR knob allows the position of the pilot controller valve to be changed manually, which is never necessary if timer is functioning properly. In any event, if pilot controller valve is not in SERVICE position, ROWPU cannot be backwashed using normal procedures. In fact, ROWPU will not even operate.

(2) Overcurrent protection is provided by an internal resettable semiconductor. In the event of an overload, the circuit breaker is reset by depressing the RESET button. If power loss erases the memory of the time control counter, an automatic homing circuit is incorporated into the system which returns the pilot controller to the service position whenever power is restored.

(3) Remove the subpanel to access the four 1 O-position rotary switches (view 2, fig. 2-74) used to set the duration (in minutes) of each phase of the backwash cycle. Ensure settings are as follows:

Switch	Function	Recommended Setting
SW 1	Primary Backwash	2
SW 2	Fast Rinse	6
SW3	Secondary Backwash	2
SW4	Conditioned Rinse	2

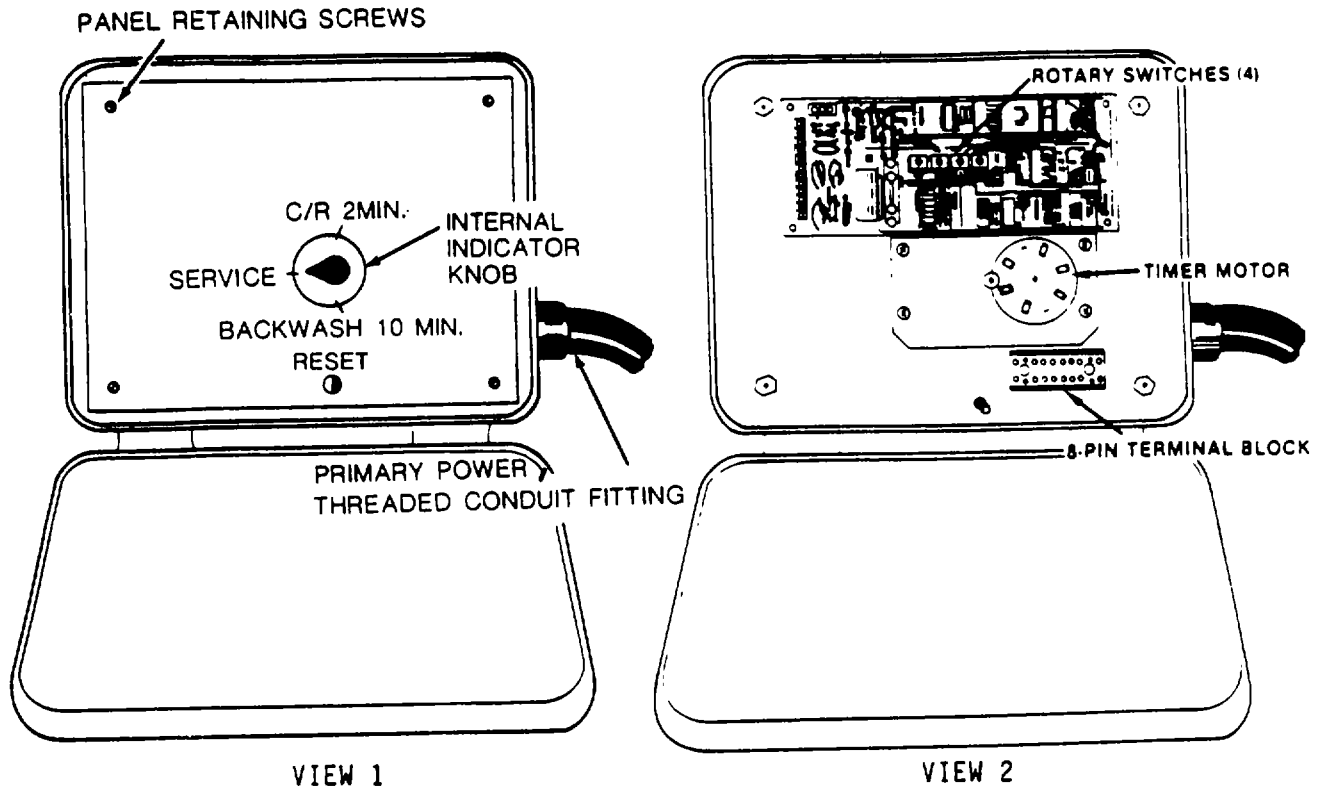

Figure 2-74. Solid-State Timer (Subpanel and Rotary Switches)

c. Normal Backwash.

- (1) Shut the ROWPU down in the normal way (para. 2-31).
- (2) Make sure R.O. ELEMENT CLEANING switch (fig. 2-74) on side of control panel is down.
- (3) Check water level in backwash tank. Tank should be full.
- (4) Ensure basket strainer in backwash pump is not clogged.
- (5) Open backwash tank valve.
- (6) Loosen draincock on bottom of backwash pump to prime pump.
- (7) Turn BACKWASH VALVE handle downward to BACKWASH.
- (8) Press RESET button on backwash timer to ensure INTERNAL INDICATOR knob is in service position (view 1, fig. 2-74).
- (9) Push BACKWASH switch up to START position and release immediately.

**CAUTION**

Do not hold START BACKWASH switch up for more than 5 seconds to avoid damage to the controls.

- (10) When a steady stream of water flows from backwash pump draincock, close draincock.

**NOTE**

Solid-state timer will come on immediately. BACKWASH PUMP ON lamp will come on, pump will start and backwash water will flow through the multimedia filter and out the waste water hose. The multimedia filter gage needle will move fully to right. During backwash, the backwash water flow rate varies automatically from 0 to 70 to 120 gpm while washing and rinsing.

Backwash with the solid-state timer lasts about 13 minutes.

- (11) When backwash is complete, BACKWASH PUMP ON Lamp will go off and multimedia gage will return to "0". When backwash pump shuts off, turn BACKWASH valve handle upward to left to NORMAL position. Close valve at brine water supply tank.

- (12) Start up the ROWPU after backwash in the normal manner (para. 2-25).

**CAUTION**

Since the multimedia filter uses brine water to backwash, it should not be drained or left inoperative following backwash without first flushing with raw water for 5 minutes. Flush by operating filter normally.

**2-27.CITRIC ACID FEED.** After 20 hours of full operation, feed citric acid solution into filtered water in order to maintain pH recommended for optimum R.O. process:

**WARNING**

Chemicals can cause sickness or even death if extreme care is not taken. Wear protective devices when working with these solutions.

- a. Put 0.75 pounds of citric acid into CITRIC ACID pail, using citric acid measure.
- b. Fill CITRIC ACID pail with 3 gallons of brine.
- c. Stir chemical and brine with wooden paddle, and pour solution into 5 gallon container.
- d. While the ROWPU is operating normally, set the citric acid chemical feed pump valve on RUN, and set chemical feed control knob to maximum setting: 8.5.
- e. Wait for 10 minutes.
- f. Draw a 250 ml water sample from brine hose at backwash tank and check for a pH reading of 5 to 8. If that reading is over 8, feed a new batch of citric acid chemical mixture, using 1.5 pounds citric acid mixed with 3 gallons brine.

- g. Set CITRIC ACID PUMP valve to PRIME. Feed is completed.

**2-28. R.O. ELEMENT CLEANING METHODS.** It will be necessary to clean the R.O. elements to improve total dissolved solids (TDS) rejection, and reduce operating pressure (P.S.I.). Two methods of cleaning elements are available. One method, used most often, is to feed citric acid solution through the vessels (para. 2-29a). The second method is to circulate Triton X-100 soapy cleaning solution through the vessels (para. 2-29b). Triton X-100 is more effective for removing dirt and silt. The R.O. elements must be cleaned:

a. Whenever the pressure shown on R.O. PRESSURE P.S.I. indicator rises to above 960 for seawater or 500 for fresh water.

b. Product water output drops several gallons per minute on PRODUCT WATER FLOW indicator, with no change in raw water temperature.

c. BRINE FLOW increases noticeably, and the adjustment of REGULATE PRODUCT FLOW valve does not correct the BRINE FLOW indication.

- d. When R.O. vessels pressure increases by 20% over initial reading.

**2-29. R.O. ELEMENT CLEANING PROCEDURE**

- a. Citric Acid Method.

**CAUTION**

R.O. ELEMENT CLEANING switch (fig. 2-47) must be in OFF position except while cleaning R.O. elements.

- (1) First backwash multimedia filter (see para. 2-26).

**WARNING**

Be sure that the drained brine water runs toward lower ground as far downstream from the raw water source as possible.



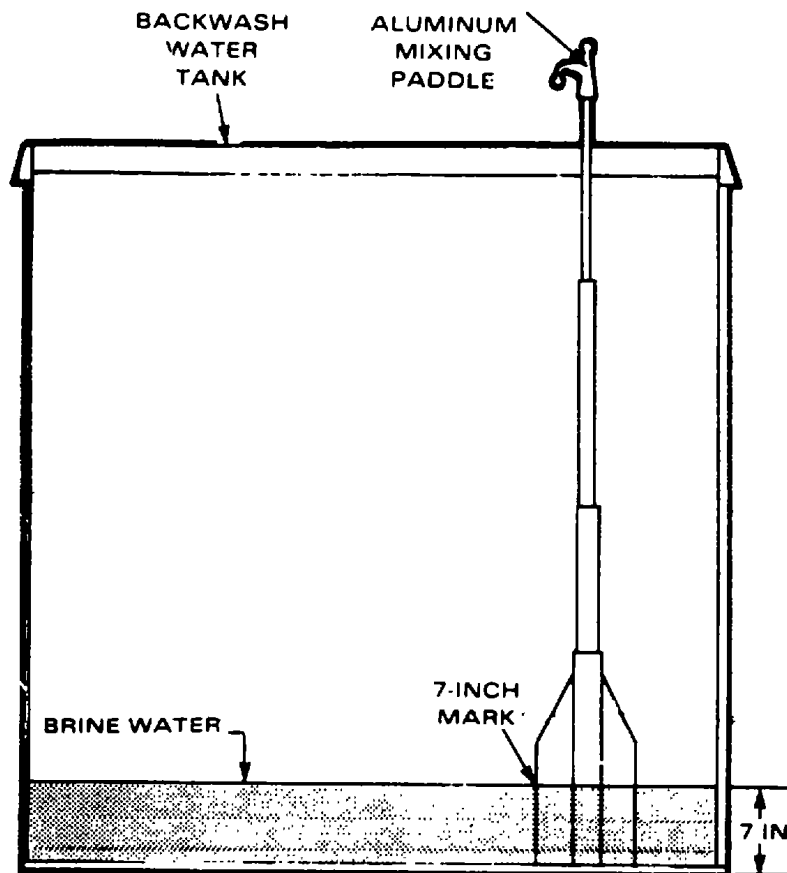

Figure 2-75. Backwash Water Tank

(2) After backwashing, adjust brine water level in tank to 7 inches. You may have to drain water from tank or operate ROWPU normally until you obtain 7 inches.

(3) Check for 7-inch brine water level with telescoping aluminum mixing paddle. Paddle has a 7-inch mark for checking the brine depth.

(4) Begin by adding 1 lb of citric acid to water in backwash water tank and mix with aluminum paddle until all granules are dissolved. (More citric acid may be added later to bring pH of brine near but not below 3.5.)

#### NOTE

If in the past, when using the same source water, brine has been very alkaline, then more citric acid may be added to start; however, never let pH of brine drop below 3.5.

(5) Remove backwash hose from outlet of the backwash pump and connect VENT VESSELS hose to outlet of backwash pump.

(6) Make sure REGULATE PRODUCT FLOW valve is open.

(7) Open VENT VESSELS valve. This valve should remain open at all times except when producing purified water.

(8) Check to see that the valve on the bottom of backwash water tank is fully open (turned fully to the left until it stops).

(9) Remove product water hose (14, fig. 2-30) from product water tank and allow hose from ROWPU to drain on the ground. Leave brine water hose in backwash water tank.

(10) Start element cleaning. Push ELEMENT CLEANING switch (fig. 2-47) up to START position. Release switch. Switch automatically goes to RUN position. Element cleaning starts.

**NOTE**

If element cleaning does not start, it may be necessary to loosen draincock on backwash pump to purge air. Close draincock when pump is primed.

(11) Within a few seconds, BRINE FLOW indicator (16, fig. 2-4) should show a flow of 16 gpm or more.

**CAUTION**

If pH of water circulating through R.O. elements drops below 3.5, element membranes may be damaged.

(12) After 5 minutes, check pH (para. 2-32) of water discharging back into brine tank; it should be near, but not below, 3.5. If it isn't, add another pound of citric acid and stir until all granules are dissolved.

**NOTE**

If in the past, when using the same source water, brine has been very alkaline, then more citric acid may be added; however, never let pH of the water circulation through R.O. elements drop below 3.5.

(13) Continue checking pH and adding 1 lb of citric acid at 5 minute intervals until pH of water is near, but not below, 3.5.

(14) Allow citric acid solution to circulate for 45 minutes. Periodically check the temperature of the water discharging back into brine tank; use thermometer in Storage Box No. 2.

**CAUTION**

Temperature of solution will rise during element cleaning. At no time should it exceed 120 degrees. If temperature rises above 120 degrees, stop recirculating citric acid solution and resume normal operation.

(15) Stop recirculation by pushing the ELEMENT CLEANING switch down to OFF.

(16) Remove VENT VESSELS hose from outlet of the backwash pump and connect BACKWASH WATER hose to backwash pump outlet.

**WARNING**

Drainage lagoon should be located downstream from unit.

(17) Drain citric acid solution into a shallow man-made lagoon a reasonable distance away from the unit. Close valve at discharge of brine water tank (para. 2-66).

(18) Perform startup procedure for normal filtering operation (para. 2-25).

(19) Allow the ROWPU to operate for 10 minutes with the brine and product water hoses out of the tanks with REGULATE PRODUCT FLOW valve fully open (turned fully to the left until it stops) to rinse the R.O. pressure vessels.

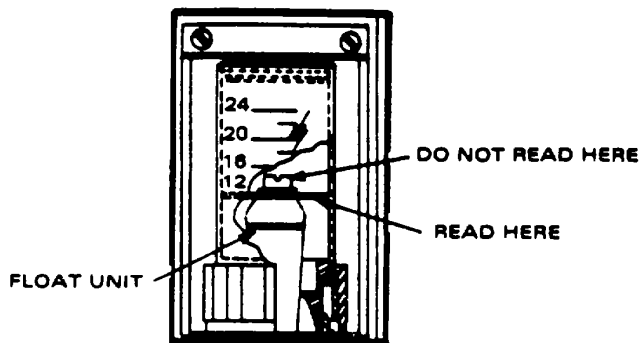

Figure 2-76. Product Water Flow Indicator

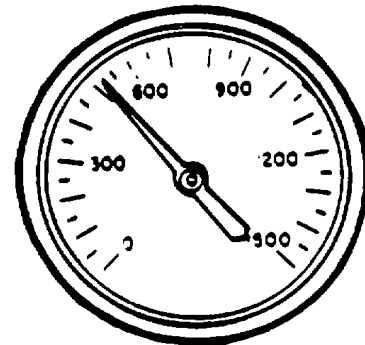

Figure 2-77. R.O. Pressure Gage

(20) Adjust REGULATE PRODUCT FLOW valve until PRODUCT WATER FLOW gage reads under 16 gpm (fresh/brackish water) or 12 (seawater), and R.O. PRESSURE PSI reads under 500 (fresh/ brackish water) or 960 (seawater).

(21) Allow ROWPU to run 3 minutes, and check product water TDS (para. 2-32c).

**NOTE**

Some elements require 24-72 hours of operation before TDS decreases to acceptable standards. If TDS is still over 1500 ppm after cleaning, allowing ROWPU to run longer may lower TDS.

(22) Only after obtaining TDS level under 1500 ppm, place product water hose back into product water tank, above water level.

b. Triton X Detergent Method. Follow same procedures for CITRIC ACID METHOD (para. 2-29a), with following exceptions:

(1) In step (4), instead of citric acid, use 800 ml (1500 gallon tank) or 2160 ml (3000 gallon tank) of overpacked SURFACTANT (Triton X detergent).

(2) In step (17), continue to rinse elements until you can no longer see suds in rinse water.

2-30. **PRODUCT WATER TOTALIZER.** Measures total amount of water produced by the ROWPU.

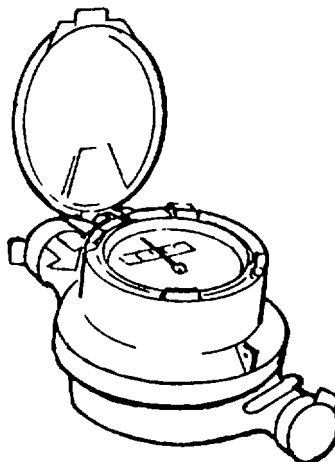

Figure 2-78. Product Water Totalizer

a. One revolution of dial equals 10 gallons of product produced.

b. The meter registers total as follows:

						0
--	--	--	--	--	--	---

└ Last digit is ZERO  
 and is constant (does not move)

c. After one revolution, a total of 10 gallons are produced and the meter will register:

					1	0
--	--	--	--	--	---	---

d. After two revolutions:

					2	0
--	--	--	--	--	---	---

d. After 10 revolutions:

				1	0	0
--	--	--	--	---	---	---

2-31. **SHUTDOWN PROCEDURES.** For normal shutdown, set valves and switches as shown in Table 2-5 and fig. 2-79.

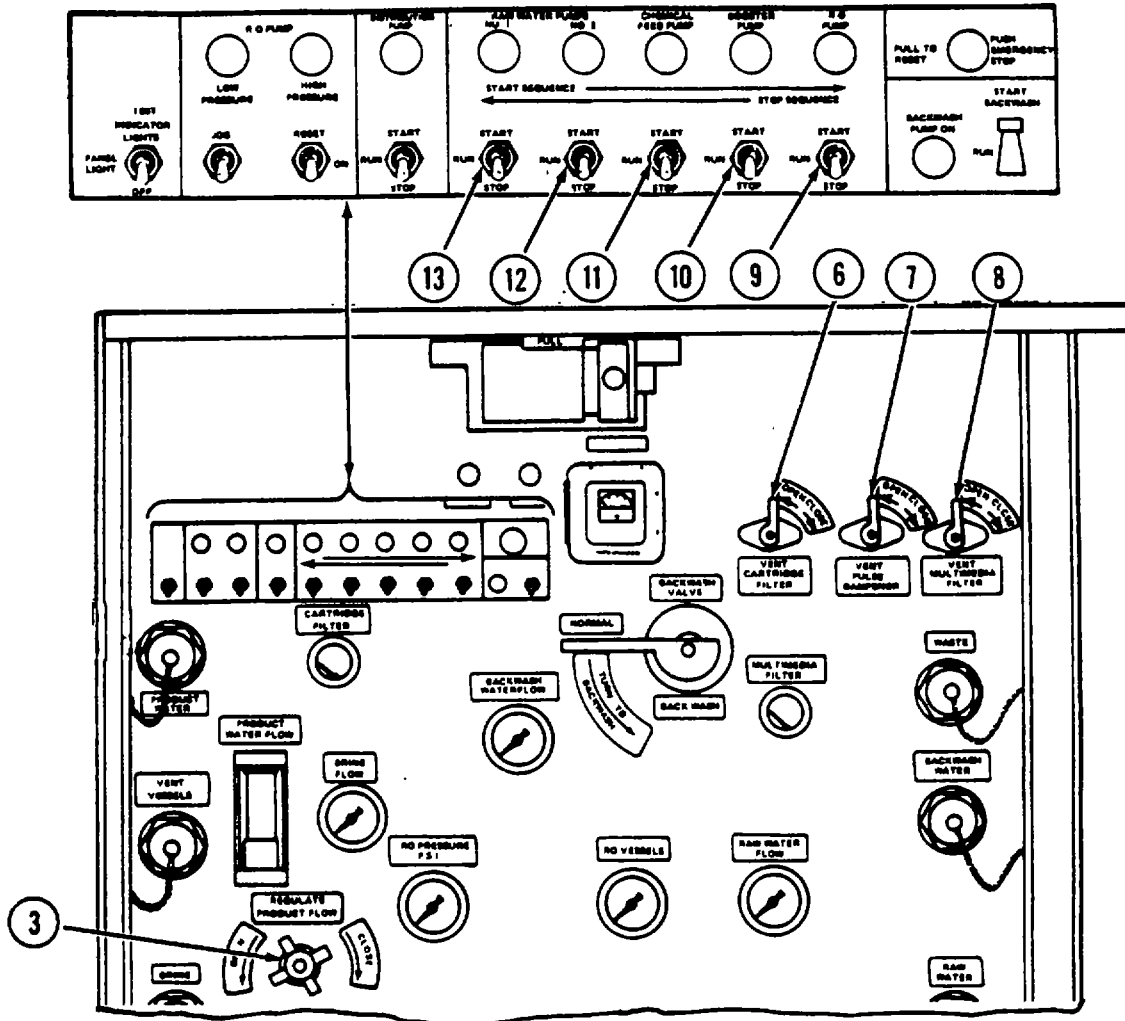

**NOTE**

Index numbers follow order of Table 2-5. For order numbers 1, 2, 4 and 5 refer to figure 2-10, 2-7, 2-6 and 2-5, respectively.

*Figure 2-79. Shutdown Position of Control Panel Switches and Valves*

**CAUTION**

Follow the exact order of shutdown steps in Table 2-5 to prevent damage to the ROWPU.

Table 2-5. Shutdown Position of Valve or Switch

Order	Valve or Switch	Position
1	CHEMICAL FEED PUMP (valves (fig. 2-68)	PRIME
2	CHEMICAL FEED CONTROL knobs (fig. 2-7)	8.5
3	REGULATE PRODUCT FLOW valve	OPEN
4	VENT PRODUCT WATER valve	OPEN
<b><u>CAUTION</u></b>		
After opening the regulate product flow valve fully, wait 5 minutes before opening vent vessels valve.		
5	VENT VESSELS valve	OPEN
6	VENT CARTRIDGE FILTER valve	OPEN
7	VENT PULSE DAMPENER valve	OPEN
8	VENT MULTIMEDIA FILTER valve	OPEN
9	R.O. PUMP switch	STOP
10	BOOSTER PUMP switch	STOP
11	CHEMICAL FEED PUMP switch	STOP
12	RAW WATER PUMPS NO. 2 switch	STOP
13	RAW WATER PUMPS NO. 1 switch	STOP

**2-32. OPERATION OF AUXILIARY EQUIPMENT.**

**WARNING**

Operating noise level of the generator set can cause hearing damage. Ear protectors, as recommended by the medical or safety officer, must be worn when working near set.

Generator sets must not be operated in enclosed areas unless exhaust discharge is properly vented to the outside. Be alert at all times during operation for odors and exposure symptoms.

a. Generator Set (Army). Instructions for operating the generator are contained in the applicable generator set manual (TM 5-6115-465-12 for NSN 6115-00-118-1240).

b. Color Comparator Test Kit. Instructions to determine the pH values and chlorine residual in water are contained in the color comparator test kit (para. 2-17, fig. 2-14). The Diethyl-P-Phenylene Diamine (DPD) tablets are not part of the test kit, but are included in Storage Box No. 3.

c. TDS Meter (Portable). The TDS (total dissolved solids) meter is a calibrated meter that measures how much electric current can flow through a sample of water. Pure water passes almost no current.

(1) Description of the TDS meter:

- (a) Reads in ppm (parts per million) or in mg/l (milligrams per liter).
- (b) Has three scales: 0 to 5 x 10, 0 to 5 x 100, and 0 to 5 x 1000.
- (c) Change scales with the range switch.

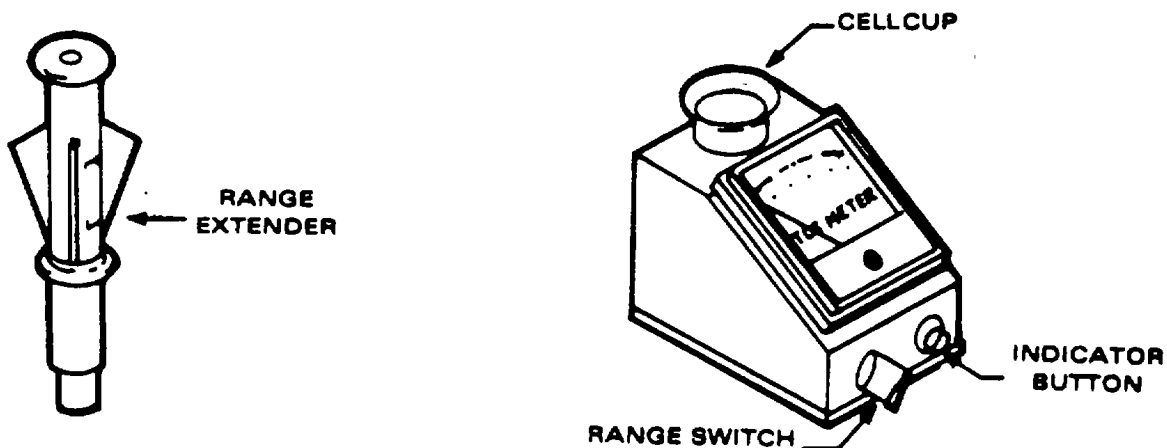

Figure 2-80. Total Dissolved Solids (TDS) Meter

**CAUTION**

Always start with meter set on the 0 to 5 x 1000 scale. If you use a lower scale first, you may damage the meter.

**NOTE**

The TDS meter is factory calibrated and suitable for use when treating fresh (lake, stream, pond, river) water. When treating seawater and brackish water, it is necessary to recalibrate the meter. If your meter has both "442" and "NaCl" internal standards stamped on the bottom panel, obtain a standard sodium chloride (NaCl) solution (Army -SC-4610-97-CL-E16; MC SL-3-08580B) and refer to subpara. (3).

(2) Recalibration instructions for meters with both internal standards (442 and NaCl) stamped on the bottom of the meter:

- (a) Set range switch to "S" (internal standard).
  - (b) Remove bottom plate to gain access to master calibration control.
  - (c) Press indicator button and hold it in.
  - (d) Adjust the master calibration control with your finger until meter reads same as the value stamped on the bottom plate for the water you will be treating (442 for fresh water and NaCl for seawater).
  - (e) Release indicator button.
  - (f) Replace bottom plate.
- (3) Recalibration instructions for meters with only "442" internal standard stamped on bottom plate:
- (a) Obtain a standard sodium chloride (NaCl) solution and note the ppm (parts per million) value printed on bottle.
  - (b) Remove snap-in disc on bottom cover of TDS meter to gain access to the master calibration control.
  - (c) Rinse cell cup three times with the standard sodium chloride (NaCl) solution, then fill again.
  - (d) Set range switch to the 1000 scale.
  - (e) Press indicator button and hold it in.
  - (f) Adjust the master calibration control until the meter reads the value on solution bottle, then release indicator button. Remember to multiply meter reading by 1000.
  - (g) Set range switch to "S" (internal standard).
  - (h) Press indicator button, and hold it in.
  - (i) Note the dial reading and write it down for future reference, then release indicator button. This value is the internal standard for a sodium chloride (NaCl) solution.
  - (j) Replace snap-in disc in bottom cover.
- (4) Calibration Check:
- (a) Set range switch to "S" (an internal standard).
  - (b) Press indicator button. Read the 0 to 5 scale to the nearest tenth.
  - (c) For fresh water, meter is ready for use if it matches the 442 ppm internal standard marked on bottom plate. For seawater or brackish water, meter is ready if its reading matches the "NaCl" internal standard, which if not stamped on bottom plate, was noted in step (3)(i).
  - (d) If reading is not the same, notify unit maintenance to replace TDS meter.



**CAUTION**

To avoid shorting TDS meter, keep the meter dry. Do not spill water or any other liquid on the meter. Do not damage meter by removing or twisting cell cup.

**NOTE**

Be sure cell cup is clean; wash with soap and water if required.

(5) Testing.

- (a) Rinse cell cup three times with water to be tested.
- (b) Fill cell cup to 1/2 inch from top with water to be tested.

**NOTE**

Do not use range extender when testing product water.

- (c) Push range extender into cup, seating the O-ring.

**CAUTION**

Always start with meter set on the 0 to 5 x 1000 scale. If you use a lower scale first, you may damage the meter.

- (d) Set range switch to 0 to 5 x 1000 scale.
- (e) Press indicator button. If reading is less than 500, switch to the 0 to 5 x 100 scale range. If reading is below 50, switch to 0 to 5 x 10 scale range.
- (f) Record highest 0-to-5 reading by range factor used to get that reading (10, 100, or 1000) to get proper value in ppm or mg/l; record.

**NOTE**

If using the range extender, multiply this value by 10.

- (g) Remove range extender and thoroughly rinse extender and cell cup using purest water available. Wipe dry with clean cloth.

**2-33. PREPARATION FOR MOVEMENT.**

**NOTE**

If operation will be reestablished within 3 days, cleaning R.O. elements is not required.

- a. Backwash MULTIMEDIA filter (para. 2-26) and clean R.O. elements (para. 2-29).
- b. Shut off ROWPU normally (para. 2-31).

- c. Remove strainer and hose from water source.
- d. Drain ROWPU pipes, filters, and connections:
  - (1) Open seven drain valves (para. 2-12b).
  - (2) Open five vent valves (para. 2-23b).
- e. Drain R.O. pump as described below:

**CAUTION**

To prevent damage to R.O. pump, do not operate R.O. PUMP JOG switch (42, fig. 2-4) more than 5 seconds at a time.

**NOTE**

The JOG switch can be used when the R.O. Pump LOW PRESSURE lamp is on.

- (1) After water stops flowing out of drains, set R.O. PUMP JOG switch (42, fig. 2-4) to JOG. Hold it there for 3 to 5 seconds to force water from pump.
  - (2) Repeat operation of R.O. pump with JOG switch until no more water comes from the DRAIN PULSE DAMPENER drain (fig. 2-41). After jogging the R.O. pump, some dripping from the drain is allowable.
  - (3) Open front and rear sample valves all of the way to allow R.O. vessels to drain. Close when fully drained.
  - (4) Tag and disconnect the lines on the multimedia filter control valve (fig. 2-15) and backwash timer pilot valve, and allow lines to drain. After draining the lines, reconnect them to the valve as tagged.
- f. Drain booster pump:
    - (1) Run BOOSTER PUMP (fig. 2-57) for no more than 5 seconds.
    - (2) Set switch to STOP.
    - (3) Repeat the last two steps until no more water comes from cartridge filter drain (fig. 2-9).
  - g. Drain chemical feed pumps as described below:

**WARNING**

Chemicals used for operating ROWPU can kill you. The chemicals alone or in mixture can be dangerous. Always wear protective clothing and make sure area is well ventilated.

- (1) Empty and rinse all chemical utility containers and fill them with brine water.
- (2) Set chemical pump valves to PRIME (fig. 2-66).

(3) Run pump motor (37, fig. 2-4) to rinse chemical pumps. Ensure all control knobs (fig. 2-7) are set to their maximum settings.

(4) Disconnect all tubing from the chemical containers.

(5) Allow pump to run for 5 to 10 seconds to empty water from chemical pumps.

(6) Stop pump motor and empty chemical containers.

(7) Drain all hoses.

(8) Ensure chemical containers are secure in rack and rack is secured inside ROWPU frame or on trailer.

h. Drain Product Water Tanks and Pump:

(1) Start and run distribution pump (40, fig. 2-4) until all water is drained from both product water tanks.

(2) Shut off distribution pump.

(3) Roll up electrical cord onto holder on pump.

i. Drain Backwash Water Tank and Backwash Pump:

**CAUTION**

Use the ELEMENT CLEANING SWITCH (23, fig. 2-47) to start the backwash pump. Using the START BACKWASH SWITCH will cause the unit to go into the automatic backwash cycle.

(1) Start and run backwash pump using ELEMENT CLEANING SWITCH, until all water is drained from brine water tank.

(2) Close backwash water (brine water) tank shutoff valve (fig. 2-69).

(3) Disconnect backwash suction hose at backwash pump.

(4) Open draincock on bottom of backwash pump. Drain pump and back wash strainer.

(5) Disconnect strainer and strap backwash strainer to frame of the pump.

(6) Close draincock on pump.

(7) Roll up electrical cord onto holder on pump.

j. Drain Raw Water Pumps No. 1 and 2, and Distribution Pump:

(1) Open pump vent valve (fig. 2-42).

(2) Open pump drain valve (fig. 2-48).

(3) Disconnect hoses, strainer and float.

- (4) Roll up electrical cords on pumps.
- k. Shut off Generator Unit according to applicable manual for generator.
- l. Prepare hoses, pumps, and tanks for movement:
  - (1) Disconnect all hoses from ROWPU panel and install caps on panel hose connections.
  - (2) Remove hoses from pumps (all except chemical feed pump) and separate hoses.
  - (3) Remove all hose adapters and distribution nozzle. Put adapters and nozzle into Storage Box No. 2.
  - (4) Roll all rubber hoses and connect the ends.
  - (5) Drain and roll canvas hoses, starting with male end (male end goes on the inside, female end on the outside).
  - (6) Put caps on all openings of portable pumps.
  - (7) Remove covers from all water storage tanks. Fold covers.
  - (8) Drain and deflate all storage tanks, remove valve from backwash tank, and cover tank openings.

**CAUTION**

If any water remains in tanks, tip tanks and drain water. Dry tanks before folding.

- (9) Fold up tanks.
  - (10) Fold up ground clothes.
  - (11) Pull out ground rods using slide hammer and store on ROWPU control panel (fig. 2-39).
- m. Refer to loading plan attached to each storage box lid and pack accessories as indicated. Be sure TDS meter is packed in its case and is secure in Storage Box No. 2. Be sure in-line TDS meter is removed from control panel and stored securely in Storage Box No. 3.
- n. Install pumps, storage boxes, pails, hoses, sledge hammer, aluminum paddle, and tanks on ROWPU. Refer to paragraph 1-6, (fig. 1-3 through 1-15) as a general packing guide.
- o. (Army) Install trailer cross braces.
  - p. (Army) Refer to fig. 2-81 and prepare trailer for movement.

**CAUTION**

In order to release trailer air brake system, towing vehicle must have 90-130 psi of air pressure.

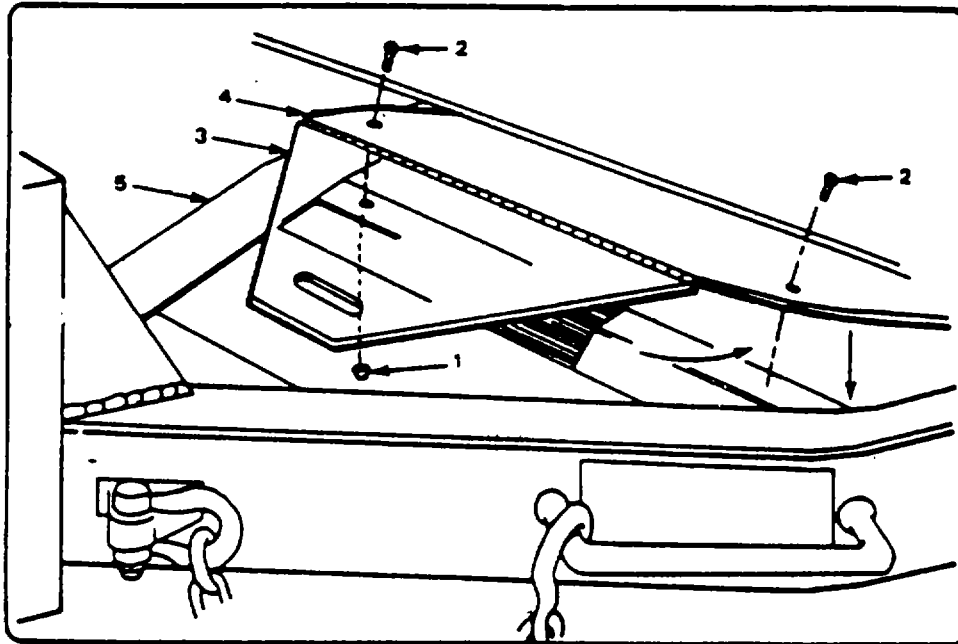

2. REMOVE NUTS (1) AND SCREWS (2) SECURING SAFETY STEP IN PLACE. LIFT STEP UP AND FOLD END PLATE (3) UNDER PLATE (4). LAY BOTH PLATES BACK DOWN AND FASTEN BOTH TO TRAILER DRAWBAR (5) WITH SECURING NUTS (1) AND SCREW (2).

Figure 2-81. Preparation for Movement (Sheet 1 of 7) (Army Model No. 0996109001)

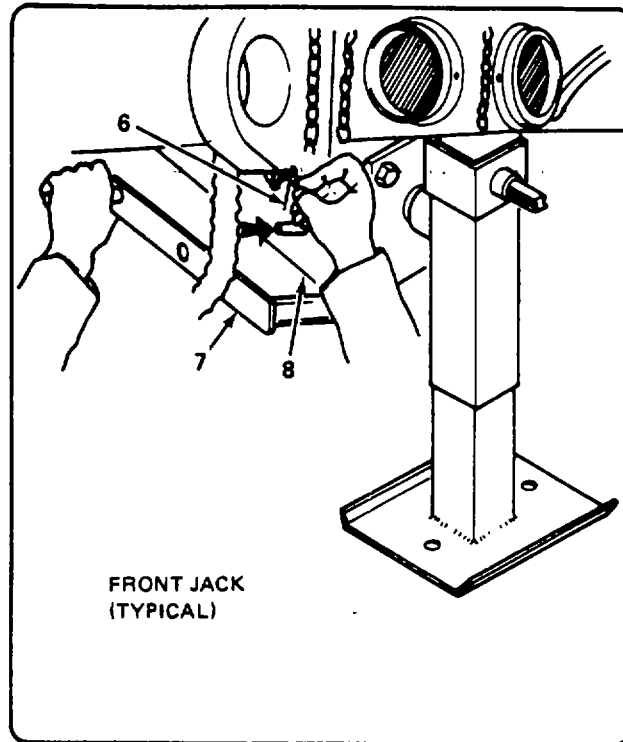

3. REMOVE SAFETY PIN (8) AND CRANK HANDLE (7) FROM REAR OF JACK SUPPORT BRACKET (8).

NOTE: Two personnel operating both leveling jacks are required to raise or lower trailer.

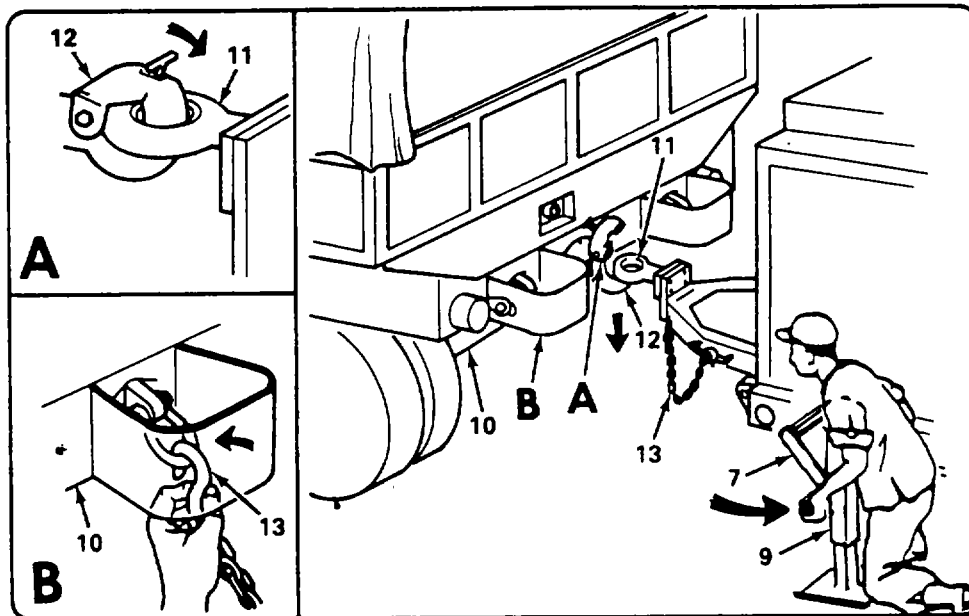

4. PLACE CRANK HANDLE (7) ON FRONT JACK (9). SLOWLY BACK TOWING VEHICLE (10) INTO POSITION SO THAT LUNETTE (11) ALIGNS WITH PINTLE (12). RAISE OR LOWER FRONT OF TRAILER, AS NECESSARY, TO POSITION LUNETTE (11) IN PINTLE (12). CLOSE PINTLE (12) AND SECURE TRAILER SAFETY CHAIN (13) TO TOWING VEHICLE (10).

Figure 2-81. Preparation for Movement (Sheet 2 of 7) (Army Model No. 0996109001)

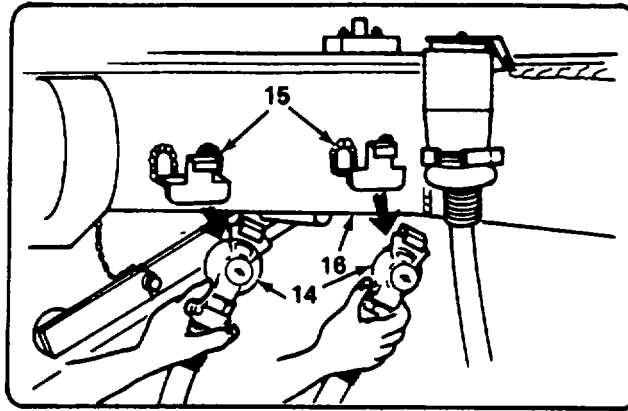

5. REMOVE AIR HOSES (14) FROM DUMMY COUPLING (15) ON TRAILER DRAWBAR (16) AND CONNECT THEM TO TOWING VEHICLE. OPEN AIR BRAKE COUPLING LEVERS ON TOWING VEHICLE.

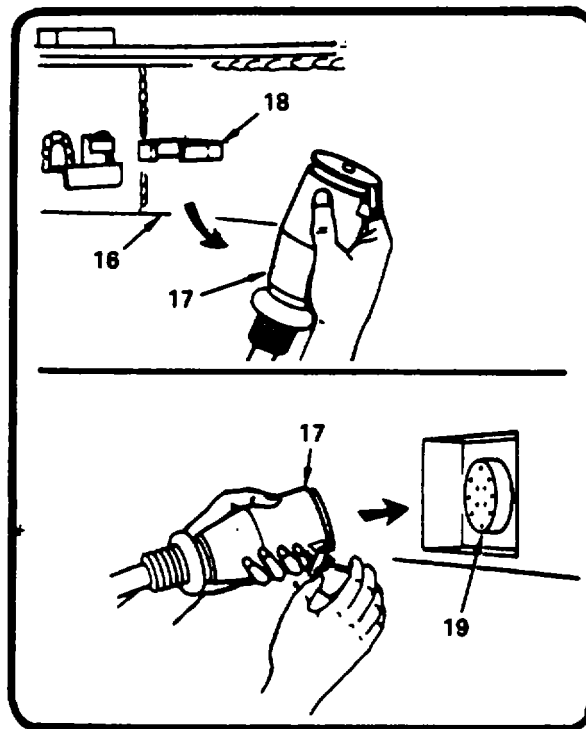

6. REMOVE ELECTRICAL CONNECTOR (17) FROM STORAGE CLIP (18) ON TRAILER DRAWBAR (16) AND CONNECT IT TO MATING RECEPTACLE (19) ON TOWING VEHICLE.

Figure 2-81. Preparation for Movement (Sheet 3 of 7) (Army Model No. 0996109001)

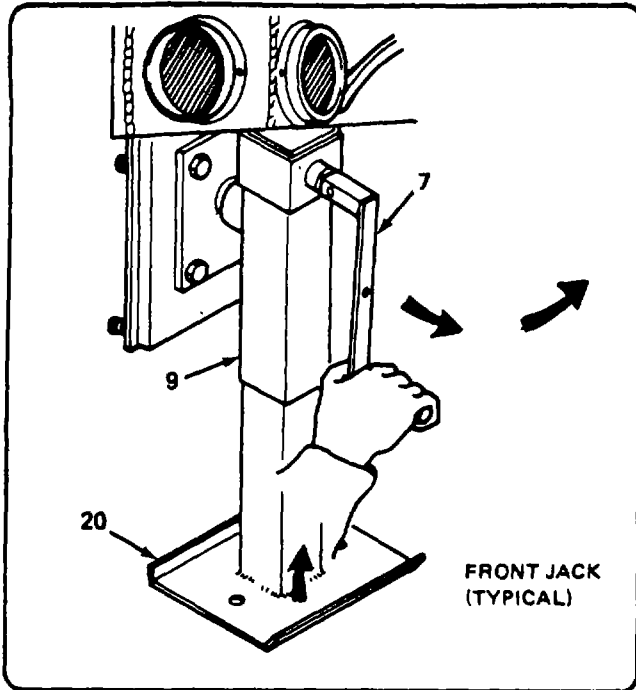

7. WITH CRANK HANDLE (7) IN POSITION ON FRONT JACK (9), TURN CRANK HANDLE COUNTERCLOCKWISE AND FULLY RAISE JACK PAD (20).

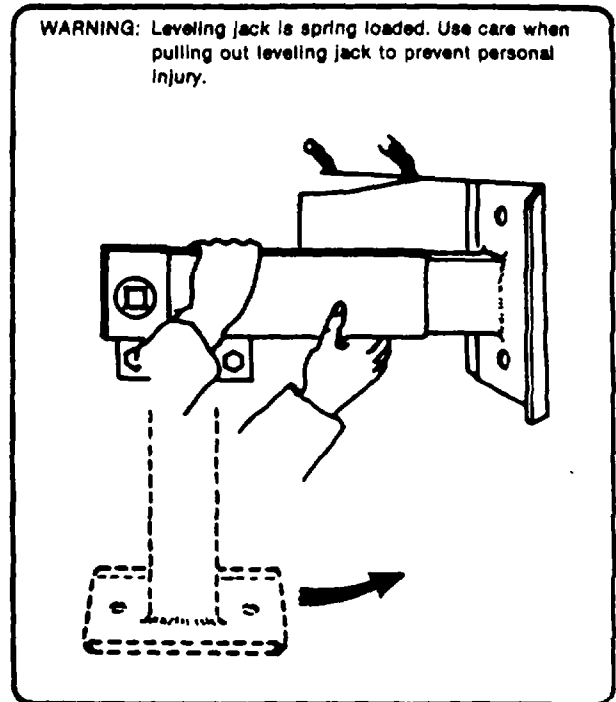

8. TO ROTATE FRONT LEVELING JACK TO HORIZONTAL POSITION, REMOVE CRANK HANDLE. GRASP JACK AND PULL STRAIGHT OUT AGAINST SPRING TENSION ROTATE JACK UP TO HORIZONTAL POSITION ALLOW JACK TO SPRING BACK TO LOCKED POSITION

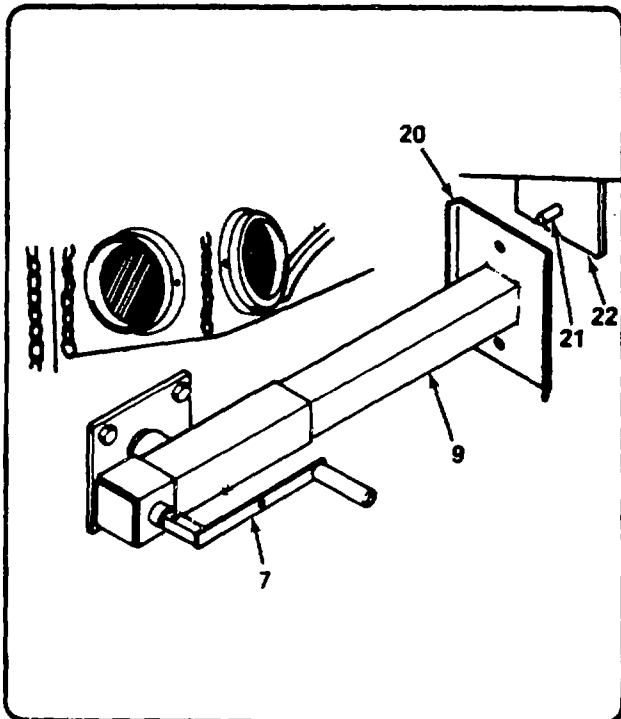

9. POSITION CRANK HANDLE (7) ON FRONT JACK (9) AND TURN HANDLE CLOCKWISE TO EXTEND JACK PAD (20). LINE UP HOLES IN JACK PAD WITH ROUND BAR (21) ON SECUREMENT PLATE (22). EXTEND JACK UNTIL JACK PAD RESTS FIRMLY AGAINST SECUREMENT PLATE.

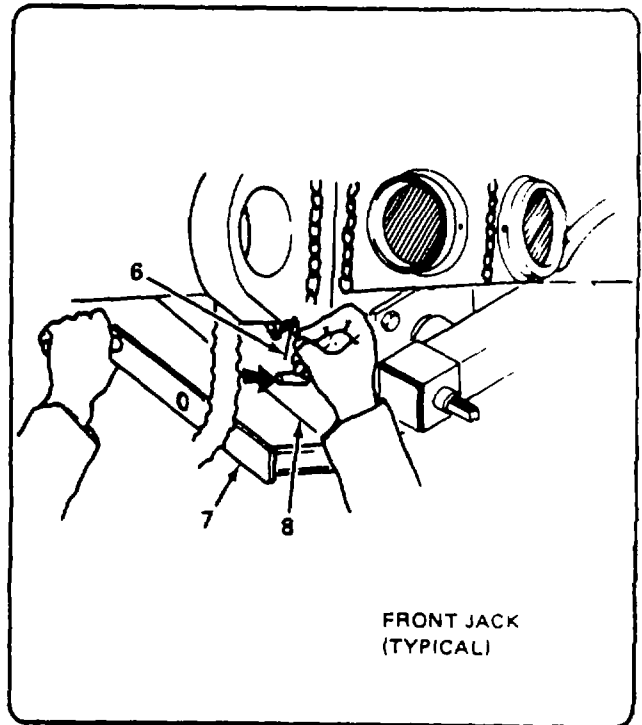

10. REPLACE CRANK HANDLE (7) ON REAR OF JACK SUPPORT BRACKET (8); INSTALL SAFETY PIN (6)

Figure 2-81. Preparation for Movement (Sheet 4 of 7) (Army Model No. 0996109001)



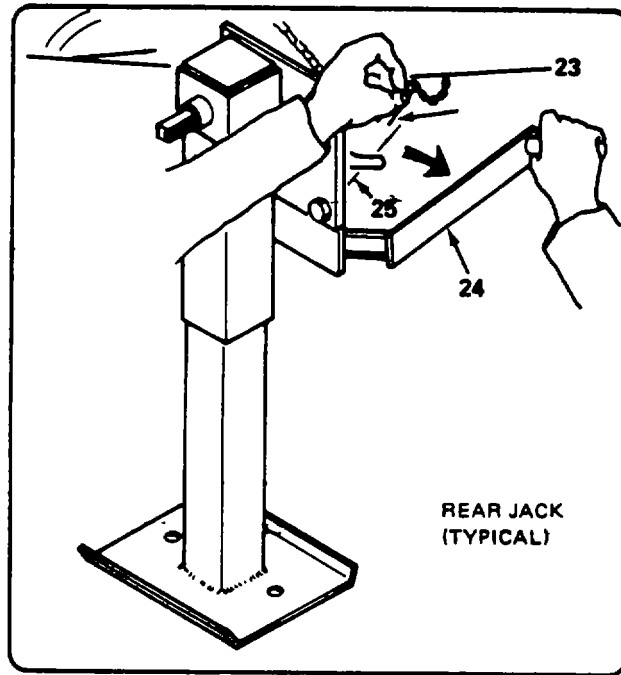

11. REMOVE SAFETY PIN (23) AND CRANK HANDLE (24) FROM REAR OF JACK SUPPORT BRACKET (25).

Figure 2-81. Preparation for Movement (Sheet 5 of 7) (Army Model No. 0996109001)

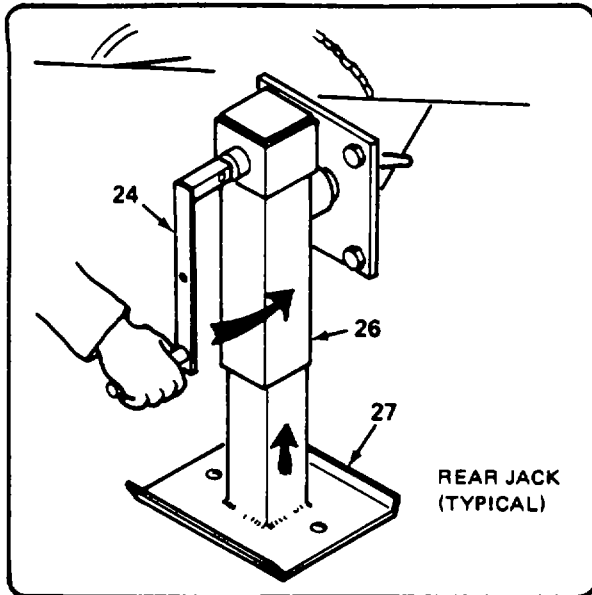

12. POSITION CRANK HANDLE (24) ON REAR JACK (26) AND TURN HANDLE COUNTERCLOCKWISE TO RAISE JACK PAD (27).

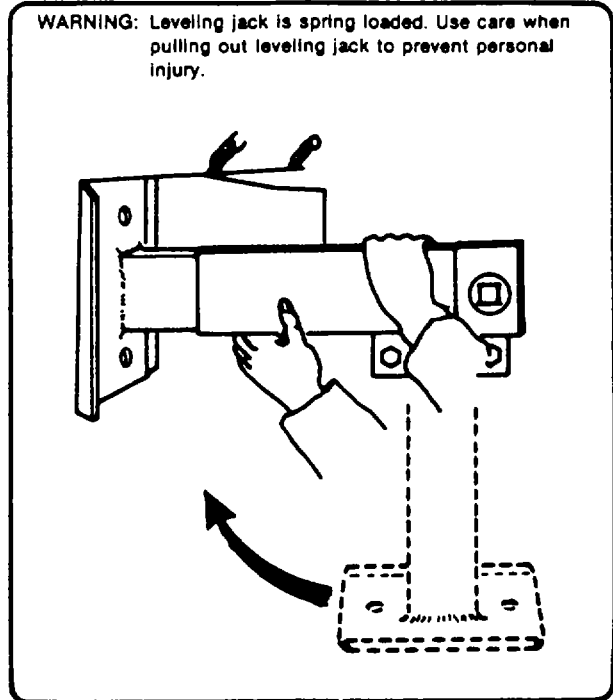

13. TO ROTATE REAR LEVELING JACK TO HORIZONTAL POSITION, REMOVE CRANK HANDLE. GRASP JACK AND PULL STRAIGHT OUT AGAINST SPRING TENSION. ROTATE JACK UP TO HORIZONTAL POSITION. ALLOW JACK TO SPRING BACK TO LOCKED POSITION.

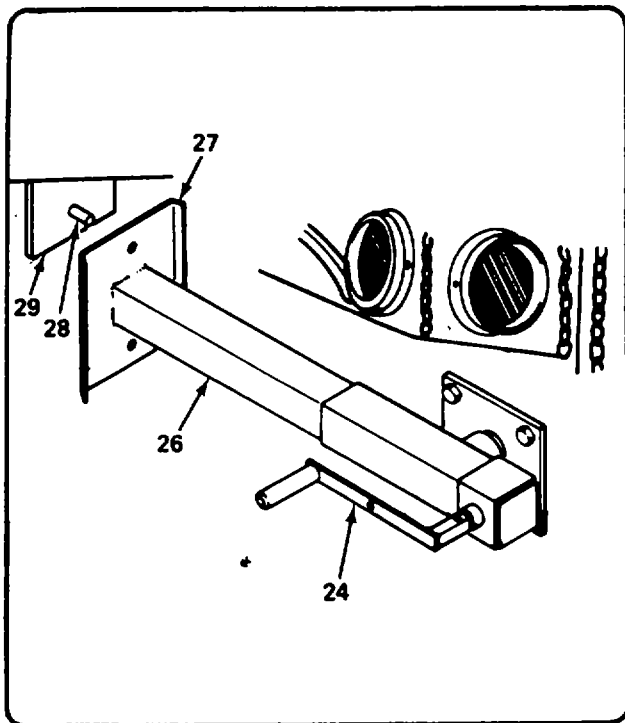

14. POSITION CRANK HANDLE (24) ON REAR JACK (26) AND TURN HANDLE CLOCKWISE TO EXTEND JACK PAD (27). LINE UP HOLE IN JACK PAD WITH ROUND BAR (28) ON SECUREMENT PLATE (29). EXTEND JACK UNTIL JACK PAD RESTS FIRMLY AGAINST SECUREMENT PLATE.

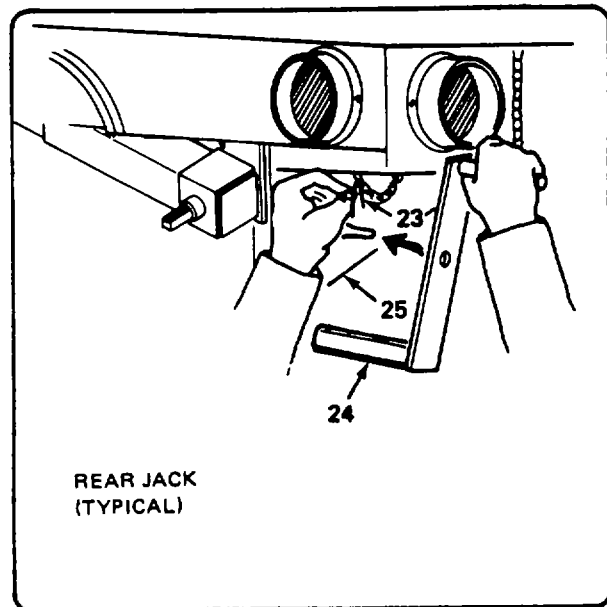

15. REPLACE CRANK HANDLE (24) ON REAR OF JACK SUPPORT BRACKET (25); INSTALL SAFETY PIN (23).

Figure 2-81. Preparation for Movement (Sheet 6 of 7) (Army Model No. 0996109001)

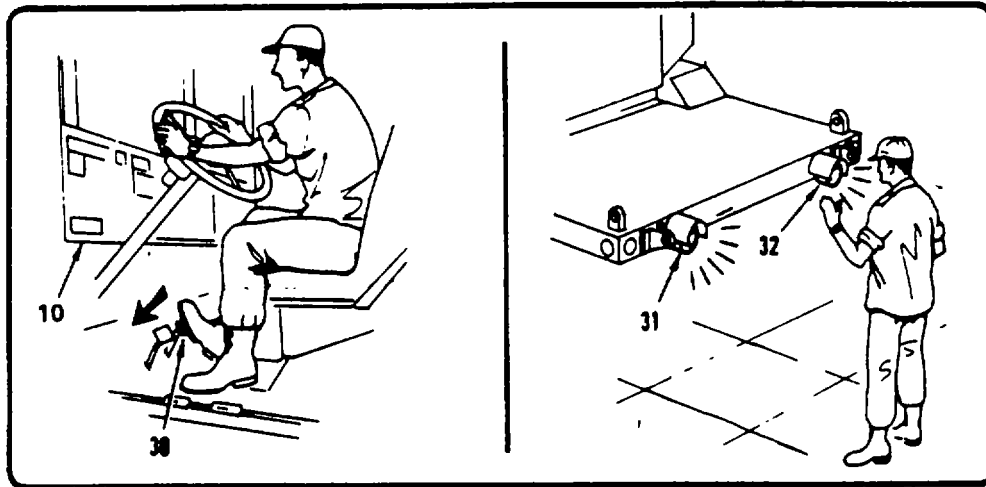

16. DEPRESS BRAKE PEDAL (30) OF TOWING VEHICLE (10); OBSERVE THAT BLACKOUT-STOPLIGHT (31) AND TAILLIGHT-STOPLIGHT ASSEMBLIES (32) AS WELL AS BRAKES OPERATE CORRECTLY. IF LIGHTS AND BRAKES OPERATE CORRECTLY, TRAILER IS READY FOR TRANSPORTING.

Figure 2-81. Preparation for Movement (Sheet 7 of 7) (Army Model No. 0996109001)

## SECTION IV. OPERATION UNDER UNUSUAL CONDITIONS

### NOTE

Refer to applicable manuals for operation of power generating equipment during unusual conditions.

### NOTE

References to trailer are for Army ROWPU only.

**2-34. FORDING.** No special procedures are required before or during fording. After fording, wash the trailer with fresh water to remove mud and other contaminants as soon as it is convenient to do so. Pay special attention to the electrical connections and brake hoses, the springs, and the suspension assembly. Lubricate the entire vehicle in accordance with the instructions in the Lubrication Order, LO 10-4610-239-12/LI 08580B-12.

**2-35. EMERGENCY PROCEDURES.** If the air supply from the towing vehicle and from the trailer air reservoir should be interrupted, the emergency spring brakes will lock. Refer to fig. 2-82 as required to reset a locked spring brake.

**2-36. WATER DEPTH/WAVE CONDITIONS.** When waves of 2 4 feet at water source exist, or when water depth is too low to prevent sand or debris from entering strainer at water source, it will be necessary to backwash multimedia filter more often.

**2-37. COLD WEATHER.** Locating, installing and operating the equipment at subfreezing temperatures requires taking precautions. Adequate shelter and heating are required when operating in temperatures below 32 °F (0 °C). When locating the equipment take advantage of existing shelter and windbreaks. Erect tenting shelters for protection. The filtered water storage tanks may be installed inside a tent or other shelter. Filtered water may be recirculated with the distribution pump between the two filtered water storage tanks to prevent freezing in the hose lines, tank outlets and pump. Fuel, coal or wood burning heaters or other heating devices may be installed inside the erected tents to protect the equipment and prevent freezing of water. When the equipment is to be shut down, all hoses must be disconnected from pumps, and all pumps, hoses, pipes and tanks drained quickly. All drain and vent valves must be opened and all equipment inspected to assure complete drainage. During cold weather, keep in mind the following warnings, cautions and procedures:

### CAUTION

Turn valves slowly during cold weather, because metal contracts and becomes very brittle.

- a. Inspect the ROWPU closely for split or frozen hoses, clogged strainer, etc.

### WARNING

To prevent hands from freezing to metal, wear rubber gloves when handling and setting valves.

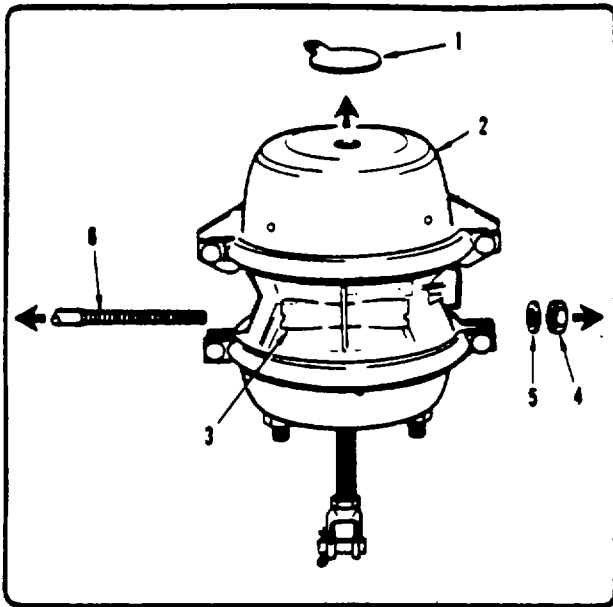

1. REMOVE DUST CAP (1) FROM TOP OF SPRING CHAMBER (2). REMOVE RELEASE STUD ASSEMBLY FROM SIDE SLEEVE (3) BY REMOVING RELEASE STUD NUT (4) AND WASHER (5) FROM RELEASE STUD (6) AND SLIDING RELEASE STUD OUT OF SLEEVE.

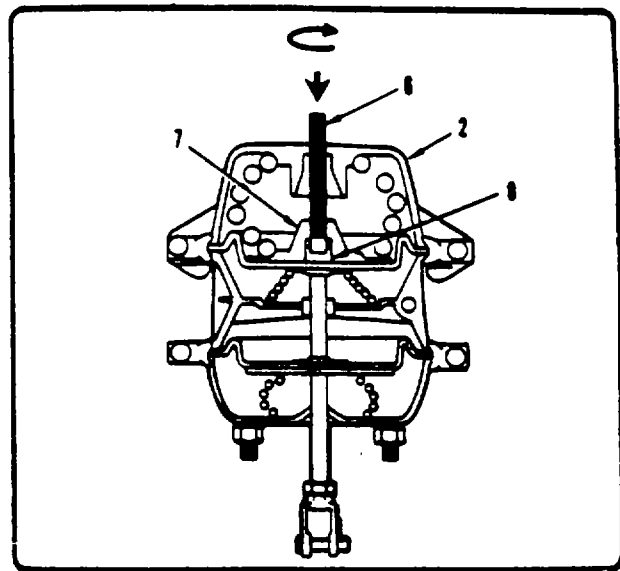

2. INSERT RELEASE STUD (6) THROUGH OPENING (WHEN DUST CAP REMOVED) OF SPRING CHAMBER (2) AND INTO THE PRESSURE PLATE (7). TURN RELEASE STUD (6) & TURN (CLOCKWISE) INTO PRESSURE PLATE (7) TO SECURE CROSSPIN (8) IN CROSSPIN AREA OF PRESSURE PLATE (7), THEN LOCK RELEASE STUD INTO MANUAL RELEASE POSITION.

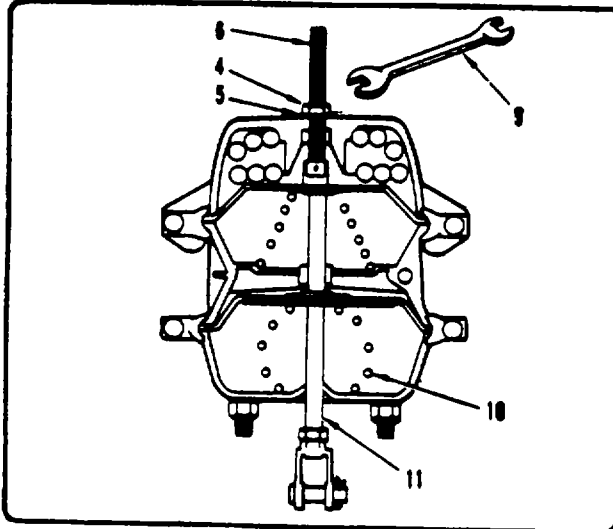

3. PLACE PREVIOUSLY REMOVED RELEASE STUD WASHER (5) AND NUT (4) ON RELEASE STUD (6) AND HAND TIGHTEN THE NUT ONTO RELEASE STUD

**CAUTION**

DO NOT APPLY TORQUE GREATER THAN 50 FT.-LBS (6.9M-KG) TO RELEASE STUD ASSEMBLY.

USE TORQUE WRENCH (9) TO TURN RELEASE STUD NUT (4) CLOCKWISE UNTIL COMPRESSION SPRING (10) IS FULLY CAGED. WHILE COMPRESSION SPRING (10) IS FULLY CAGED, OBSERVE THAT SERVICE PUSH ROD (11) IS RETRACTING AS RELEASE STUD NUT (4) IS BEING TIGHTENED. WHEN COMPRESSION SPRING (10) IS FULLY CAGED, SPRING BRAKE IS MECHANICALLY RELEASED.

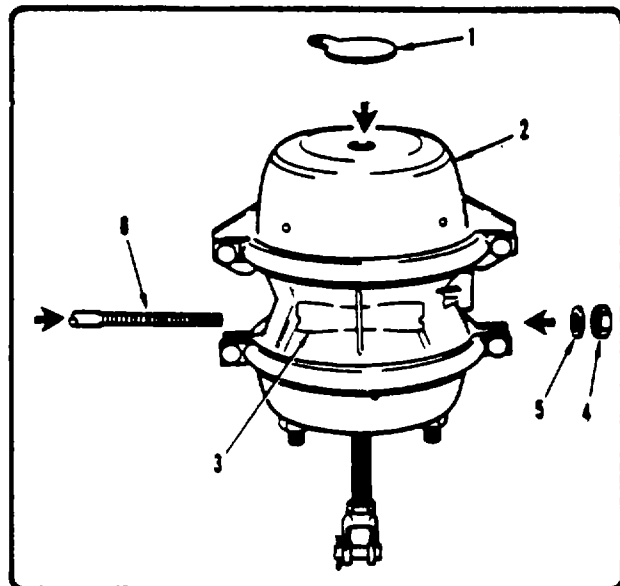

4. AFTER OPERATIONAL AIR PRESSURE BUILDS UP IN BRAKE CHAMBER AIR RESERVOIR, REMOVE RELEASE STUD ASSEMBLY FROM SPRING CHAMBER (2) AND STOW IN SIDE SLEEVE (3), BY INSERTING RELEASE STUD (6) THROUGH SIDE SLEEVE (3) AND INSTALL WASHER (5) AND NUT (4). REPLACE DUST CAP (1) ON SPRING CHAMBER (2).

Figure 2-82. Resetting Locked Spring Brake (Army)

**CAUTION**

If raw water hoses freeze, poor water flow will reduce pressure in R.O. pump. The R.O. PUMP LOW PRESSURE lamp will come on and R.O. pump will shut itself off. Bring hoses under cover until ice melts.

**NOTE**

The ROWPU produces less product water when the temperature of raw water drops.

b. When the ROWPU is shut down during cold weather (temperature falls below 32 °F (0 °C), remove the R.O. elements (para. 3-4) . Store the elements indoors or in a tent where the temperature is above freezing and allow them to dry. Drain all water from ROWPU as follows:

**WARNING**

Make sure drained water runs toward lower ground (downstream) as far from the raw water source as possible.

(1) Drain ROWPU pipe, filters, and connections:

(a) Open seven drain valves (para. 2-23a).

(b) Open five vent valves (para. 2-23b).

(c) Facing trailer from towing end, jack-up left side to permit maximum water drainage through drain valves.

(2) Drain R.O. pump as described below:

**CAUTION**

Do not operate R.O. PUMP JOG switch (42, fig. 2-4) for more than 5 seconds at a time. You will damage pump if you do.

**NOTE**

The JOG switch can be used when the R.O. pump LOW PRESSURE lamp is on.

(a) After water stops flowing out of drains, set R.O. PUMP JOG switch to JOG. Hold it there for 3 to 5 seconds to force water from pump.

(b) Repeat operation of R.O. PUMP with JOG switch until no more water comes from the DRAIN PULSE DAMPENER drain (fig. 2-41).

(c) Disconnect plastic tubing from bottom of R.O. vessels so they can drain. Reconnect tubing when vessels are fully drained.

(d) Tag and disconnect the lines on the multimedia filter control valve (fig. 2-15) and backwash timer pilot valve and allow lines to dry. After draining the lines, reconnect them to valves as tagged.

(3) Drain booster pump:

(a) Run BOOSTER PUMP for no more than 5 seconds (fig. 2-57).

(b) Set switch to STOP.

(c) Repeat the last two steps until no more water comes from cartridge filter drain (fig. 2-39).

(4) Drain chemical feed pumps as described below:

**WARNING**

Chemicals can cause sickness or death if extreme care is not taken. Wear protective devices when working with these solutions.

**CAUTION**

To avoid staining, be careful not to spill any solution on clothes or equipment. If any solution is spilled, it should be washed away immediately with water.

(a) Empty and rinse all chemical containers and fill them with brine water.

(b) Set chemical pump valves to PRIME (fig. 2-66).

(c) Run pump motor to rinse chemical pumps. Set all control knobs (fig. 2-7) to maximum setting.

(d) Remove quick disconnectors from all chemical containers.

(e) Allow pump to run (37, fig. 2-4) for 5 to 10 seconds to empty water from chemical pumps.

(f) Stop pump motor and empty chemical containers.

(g) Set chemical pumps valves to off position.

(5) Drain distribution pump and raw water pumps No. 1 and No. 2:

(a) Disconnect inlet and outlet hoses.

(b) Tip pump toward each connection to permit drainage.

(c) Open pump vent valve (fig. 2-42).

(d) Open pump drain valve (fig. 2-48).

(e) Run pumps (38-40, fig. 2-4) for less than 5 second intervals until all water is out.

(f) Shut off pumps.

- (6) Drain backwash pump:
  - (a) Disconnect backwash suction hose at backwash pump.
  - (b) Open draincock on bottom of backwash pump. Drain pump and backwash strainer.
  - (c) Close draincock on pump.

#### **2-38. HOT WEATHER**

- a. When the air temperature is 90°F (32°C) or above, park in the shade and leave canvas cover over the ROWPU. Leave control panel uncovered.

#### **NOTE**

The motors will automatically shut off if they overheat.

- b. Check raw water and product water more often during hot weather.

#### **NOTE**

Plant life in water will clog multimedia filter and, therefore, reduce time between filter backwashings during hot weather.

- c. Visually check wire insulation carefully for damage.

#### **2-39. DUSTY AND SANDY AREAS**

- a. Protect equipment. Leave side covers down except over control panel.
- b. Keep ground around ROWPU damp to prevent loose, blowing sand and dirt.
- c. Cover all water storage tanks.

#### **2-40. RAINY AND DAMP AREAS**

#### **CAUTION**

To avoid electrical shorts, keep electrical items dry.

- a. Provide good water drainage.
- b. Protect chemicals.

#### **2-41. SALTWATER AREAS**

- a. When preparing for movement after saltwater operations, perform PREPARATION FOR MOVEMENT procedure (para. 2-33a).
- b. After backwash is completed, drain brine tank and setchemical feed control valves to prime. Place the product water discharge hose into the brine water tank. Operate the ROWPU to produce nonchlorinated product water (minimum 1,000 gallons).



- c. When the tank is full or the minimum requirement is met, shut down the ROWPU (para. 2-31).
- d. Remove the raw water strainer and hose from the source and place it in the tank of NONCHLORINATED product water.
- e. Follow INITIAL ADJUSTMENTS AND CHECKS (para. 2-23) and OPERATING PROCEDURE (para. 2-25), except for moving the chemical feed valves to run (NO CHEMICALS SHOULD BE INJECTED INTO THE SYSTEM DURING THIS PROCEDURE), until the nonchlorinated tank is empty.
- f. Shut down the ROWPU following SHUTDOWN PROCEDURES (para. 2-31). This procedure should be used to flush the salt deposits and bacteria from the system and the R.O. elements. By flushing this from the system, it slows corrosion and bacterial growth.

## **2-42. NUCLEAR OR CHEMICAL CONTAMINATED AREAS**

- a. The ROWPU has overpack items which are used as a posttreatment when nuclear or chemical contaminants are present. The equipment consists of a cartridge to remove nuclear contaminants, a cartridge used to remove chemical contaminants, and the adapters, bushings, clamps, couplings, reducers, and tubing needed for assembly.

### **WARNING**

Radioactive contaminants are potentially hazardous. Use extreme care in replacing cartridges and follow safe procedures in their handling and disposal.

### **NOTE**

Do not operate chlorination feed pump during NBC operation.

- b. For nuclear, biological OR chemical contamination, use BOTH the cartridge marked "FOR USE WITH RADIOACTIVE CONTAMINATED WATER ONLY" AND the cartridge marked "FOR USE WITH CHEMICALLY CONTAMINATED WATER ONLY."
- c. Exchange the inlet and outlet raw water pump adapter which is used in the NBC system and prepare to assemble NBC filters between two raw water tanks as shown in figure 2-80.

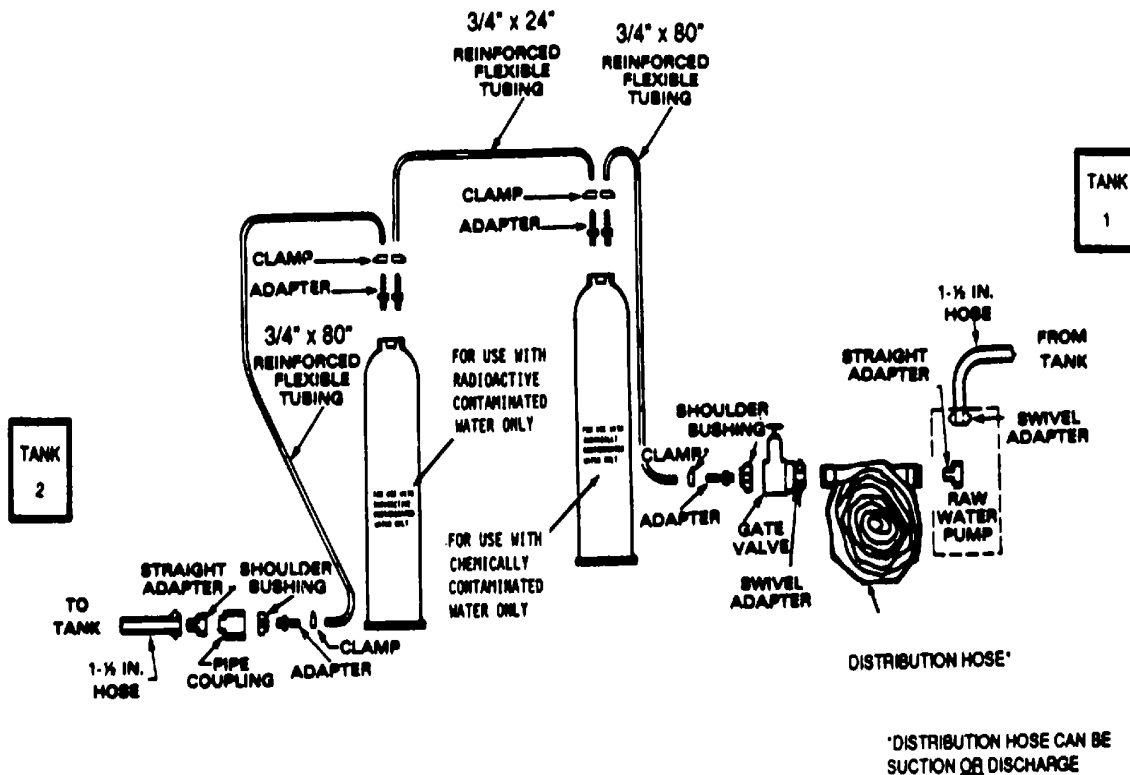

Figure 2-83. Nuclear and Chemical Filter Installation

- d. Use one of the raw water pumps to force the water through the NBC cartridges. Install raw water pump (fig. 2-83).
- (1) Install 1 1/2 in. suction hose from raw water tank and swivel adapter on raw water pump.
  - (2) Attach female end of distribution (suction or discharge) hose to straight adapter on raw water pump.
  - (3) Attach swivel adapter to gate valve and attach male end of distribution hose to swivel adapter.
  - (4) Attach shoulder bushing and adapter to gate valve.

**NOTE**

The NBC cartridges should be positioned so that the cartridge marked 'FOR USE WITH CHEMICALLY CONTAMINATED WATER ONLY' is **FIRST** in the series. Position the cartridge marked "FOR USE WITH RADIOACTIVE CONTAMINATED WATER" so that water is filtered through this cartridge **LAST** as shown in fig. 2-83

- e. Assemble the NBC cartridge in series (fig. 2-83).

**WARNING**

Be sure to follow the setup procedures in steps 1 through 4 below. Pay special attention to the INPUT and OUTPUT labels on the top of the NBC cartridges when connecting the 3/4 in. reinforced flexible tubing to the cartridges.

- (1) Slide clamp over end of one section of 3/4 in. x 80 in. flexible tubing. Attach tubing to adapter on gate valve and close clamp.
  - (2) Slide clamp over other end of tubing.
  - (3) Remove plug from INLET port on FOR USE WITH CHEMICALLY CONTAMINATED WATER cartridge and insert adapter.
  - (4) Attach tubing to adapter on INLET port and close clamp.
  - (5) Cut one section of 3/4 in. x 80 in. flexible tubing to a maximum length of 24 in.
  - (6) Slide clamp over end of tubing.
  - (7) Remove plug from OUTLET port on FOR USE WITH CHEMICALLY CONTAMINATED WATER cartridge and insert adapter into cartridge.
  - (8) Attach tubing to adapter on OUTLET port and close clamp.
  - (9) Remove plug from INLET port on FOR USE WITH RADIOACTIVE CONTAMINATED WATER cartridge and insert adapter into cartridge.
  - (10) Slide clamp over end of tubing.
  - (11) Attach tubing to adapter on INLET port and close clamp.
  - (12) Slide clamp over end of second section of 3/4 in. x 80 in. flexible tubing.
  - (13) Remove plug from OUTLET port on FOR USE WITH RADIOACTIVE CONTAMINATED WATER cartridge and insert adapter.
  - (14) Attach tubing to adapter on OUTLET port and close clamp.
- f. Complete connection of NBC cartridge to second raw water tank (fig. 2-83).
- (1) Slide clamp over remaining end of 3/4 in. x 80 in. flexible tubing.
  - (2) Insert adapter into tubing and close clamp.
  - (3) Attach shoulder bushing, pipe coupling, and straight adapter to 1 1/2 in. discharge hose and connect to second raw water tank (fig. 2-83).

**NOTE**

Do not operate chlorination feed pump during NBC operation.

- g. During NBC operation, it is necessary to chlorinate the second tank by hand.
- h. With the exception of the chlorination feed pump, operate the ROWPU using normal operating procedures.
- i. Change the cartridges after every 100 hours of operating time.

## CHAPTER 3

### MAINTENANCE INSTRUCTIONS

#### SECTION I. LUBRICATION INSTRUCTIONS

**3-1. LUBRICATION ORDER.** For lubrication instructions for the flatbed cargo trailer and ROWPU refer to Lubrication Orders LO 10 4610-239-12/LI 08580B-12.

#### SECTION II. TROUBLESHOOTING PROCEDURES

**3-2. TROUBLESHOOTING TABLE.** To troubleshoot, refer to Tables 3-1 and 3-2.

a. Each table lists the common malfunctions which may be encountered during the operation or maintenance of the flatbed trailer and the ROWPU. Perform the tests/inspection and corrective actions in the order listed.

b. This manual cannot list all malfunctions that may occur, nor all tests or inspections and corrective actions. If a malfunction is not listed or is not corrected by listed corrective actions, notify the appropriate supervisor.

*Table 3-1. (Army) Troubleshooting*

---

MALFUNCTION
TEST OR INSPECTION
CORRECTIVE ACTION

---

#### ELECTRICAL (TRAILER)

##### 1. LIGHTS DON'T WORK.

Step 1. Manually check trailer cable for proper connection to receptacle on towing vehicle.

Connect cable properly.

Step 2. Visually check both receptacle on towing vehicle and plug on cable to be sure all contacts are free of dirt, oil, and other contaminants.

Check for damaged receptacle.

a. Clean all connectors to remove corrosion and contaminants.

b. If receptacle is damaged, refer to unit maintenance.

Step 3. Visually and manually check wiring harness for loose or corroded connections, or damaged cable.

a. Tighten loose connections.

b. Clean corroded connections.

Table 3-1. (Army) Troubleshooting

<b>MALFUNCTION</b>	<b>TEST OR INSPECTION</b>	<b>CORRECTIVE ACTION</b>
		<ul style="list-style-type: none"><li>c. If cable is damaged, refer to unit maintenance.</li></ul>
	Step 4. Visually check ground connection at receptacle and check ground wire to towing vehicle.	<ul style="list-style-type: none"><li>If ground wire is loose or making poor contact, reposition wire and tighten connections.</li></ul>
	Step 5. Visually check all lamps.	<ul style="list-style-type: none"><li>a. Replace all burnt out lamp(s).</li><li>b. If lamps are not defective, notify unit maintenance of trouble.</li></ul>
<b>2</b>	<b>LIGHTS OPERATE INTERMITTENTLY.</b>	
	Step 1. Visually and manually check cable assembly connectors and towing vehicle mating receptacle connections for proper contact.	<ul style="list-style-type: none"><li>Tighten all connectors to ensure proper contact.</li></ul>
	Step 2. Visually check all contacts for contaminants such as oil, water, dirt, and corrosion.	<ul style="list-style-type: none"><li>Clean all connectors to remove corrosion and contaminants.</li></ul>
	Step 3. Visually check entire cable assembly for partially severed cable. If cable is damaged, refer to unit maintenance.	
	Step 4. Check that ground wires on trailer and towing vehicle are making proper contact.	<ul style="list-style-type: none"><li>Clean ground wire connections and secure tightly as necessary.</li></ul>
<b>3.</b>	<b>LIGHTS ARE DIM.</b>	
	Step 1. Check trailer cable to be sure there are no damaged or broken wires, or corrosion on contacts. Check ground wire on both the trailer and on the towing vehicle.	<ul style="list-style-type: none"><li>a. If cable is damaged, refer to unit maintenance.</li><li>b. If cable is not damaged, clean all contacts to remove contaminants.</li><li>c. Clean and tighten ground connections.</li></ul>
	Step 2. Check that correct lamps are installed, and securely seated in their sockets.	<ul style="list-style-type: none"><li>a. Replace incorrect lamps with correct type.</li></ul>

Table 3-1. (Army) Troubleshooting

---

<b>MALFUNCTION</b>
<b>TEST OR INSPECTION</b>
<b>CORRECTIVE ACTION</b>

---

- b. Tighten lamps found loose in their sockets.
- c. If trouble is still present, refer to unit maintenance.

**4. WRONG LIGHT GOES ON.**

- Step 1. Will require a check of the cable assembly coding and voltages.  
Notify unit maintenance.

**AIR BRAKE SYSTEM (TRAILER)**

**1. SYSTEM INOPERATIVE.**

- Step 1. Inspect air line hookup to be sure lines are not crossed.  
Disconnect air lines and reconnect correctly.
- Step 2. Listen for escaping air, and locate defective line or fixture.  
Notify unit maintenance.
- Step 3. Check the air system of the towing vehicle for leaks or lack of pressure.  
Notify unit maintenance.

**2. BRAKES REMAIN LOCKED.**

- Step 1. Check for cause of the lack of air pressure.  
Notify unit maintenance.
- Step 2. Check the operation of the emergency/relay valve.  
Notify unit maintenance.
- Step 3. Check to see if the compression springs have locked the brakes (wheels will not turn if springs have locked).  
Locate and correct the cause of the loss of air pressure; then refer to figure 2-82 in this manual for instructions for resetting a locked spring brake.

Table 3-1. (Army) Troubleshooting

---

<b>MALFUNCTION</b>	<b>TEST OR INSPECTION</b>	<b>CORRECTIVE ACTION</b>
--------------------	---------------------------	--------------------------

---

**3. BRAKES ON ONE SIDE ENGAGE BEFORE THOSE ON THE OTHER SIDE.**

Step 1. Check the movement of the slack adjusters to see if they are out of adjustment.  
Notify unit maintenance.

Step 2. Check the brake camshaft movement to see if there is any restriction on movement.  
Notify unit maintenance.

**4. BRAKES SLIP**

Step 1. Check brake adjustment, and inspect for defective brake assembly parts.  
Notify unit maintenance to adjust brakes or replace defective parts.

---

Table 3-2. Troubleshooting (ROWPU)

---

<b>MALFUNCTION</b>	<b>TEST OR INSPECTION</b>	<b>CORRECTIVE ACTION</b>
--------------------	---------------------------	--------------------------

---

**1. ANY BLUE PUMP LAMP GOES OFF.**

Step 1. Check to see if associated pump is operating. For R.O. pumps, see if sheave is turning; for other pumps, rest hand lightly on the motor casing to feel for motor vibrations.

- a. If pump is not operating, check and reset circuit breaker (fig. 2-4, sheet 3 of 3) and then immediately try to restart pump. Do so only one time.
- b. If pump fails to start, notify unit maintenance.
- c. Shut down ROWPU in normal manner (para. 2-31) except when only one raw water pump fails or distribution pump fails. In these two cases the ROWPU can still be operated.

Table 3-2. Troubleshooting (ROWPU) (continued)

<b>MALFUNCTION</b>	<b>TEST OR INSPECTION</b>	<b>CORRECTIVE ACTION</b>
	Step 2. If pump is operating, check indicator lamp to see if bulb is burned out.	<ul style="list-style-type: none"><li>a. Replace defective bulb using lamp puller (para. 3-10).</li><li>b. If bulb is not defective, notify unit maintenance.</li></ul>
<b>2. RAW WATER FLOW INDICATOR DROPS TO NEAR ZERO; BOTH RAW WATER PUMP BLUE LAMPS ARE ON.</b>	Step 1. Check to see that both raw water pumps are operating. Listen to motor and rest hand lightly on motor casing to feel for vibration.	<ul style="list-style-type: none"><li>a. If pump is not operating, check and reset circuit breaker (fig. 2-4) and then immediately attempt to restart. Do so only one time.</li><li>b. If pump fails to start, notify unit maintenance and remove defective raw water pump from cycle.</li></ul>
	Step 2. Check for loose hose connections or damaged hose sections.	<ul style="list-style-type: none"><li>a. Tighten loose connections.</li><li>b. Replace damaged hose sections.</li></ul>
	Step 3. Check to see if input strainer is completely under water.	<ul style="list-style-type: none"><li>a. Lengthen strainer rope.</li><li>b. Move intake to deeper water.</li></ul>
	Step 4. Check to see if input strainer is clogged.	<ul style="list-style-type: none"><li>a. Clean debris from input strainer.</li><li>b. Shorten strainer rope so it does not rest on bottom of raw water source.</li><li>c. Make sure raw water pump is sufficiently close to raw water source.</li></ul>
<b>3. CARTRIDGE FILTER GAGE RISES ABOVE 20 PSID.</b>	Step 1. Make a turbidity tube check (para.2-24p) of water taken from DRAIN NO. 1 CARTRIDGE FILTER valve (Fig2-41).	



Table 3-2. Troubleshooting (ROWPU) (continued)

---

<b>MALFUNCTION</b>	<b>TEST OR INSPECTION</b>	<b>CORRECTIVE ACTION</b>
		<ul style="list-style-type: none"><li>a. If water is turbid, shut down ROWPU in normal manner (para. 2-29) and change cartridge filter elements (para. 3-5).</li><li>b. If water is clear, notify unit maintenance because gage may be defective.</li></ul>
<b>4. REDUCED PRODUCT WATER FLOW; R.O. PRESSURE PSI ADJUSTED TO 960 FOR SALTWATER, 500 FOR FRESH AND BRACKISH WATER.</b>		

---

**NOTE**

ROWPU produces less product water when raw water source temperature drops (3 % less per degree Celsius drop).

Step 1. Check R.O. vessels for leaks caused by loose end caps or defective end cap O-rings.

- a. Tighten loose nuts (para. 3-4h(15)).
- b. Replace defective end cap Orings (see para. 3-4c - elements need not be replaced).

Step 2. Check R.O. vessel gage for reading higher than 100 psid.

**NOTE**

Membrane scaling may cause reduced product water flow without increasing R.O. vessel pressure. Cleaning elements when vessel pressure is under 100 psid may improve flow.

Clean R.O. elements (para. 2-28).

**5 PRODUCT WATER FLOW READING RISES ABOVE 16 GPM (FRESH/ BRACKISH), 12 (SEAWATER) AND CANNOT BE LOWERED USING REGULATE PRODUCT FLOW VALVE.**

Step 1. Check the TDS of product water from each R.O. vessel as follows:

- a. Use sample valves to collect product water sample. Do NOT disconnect product water hoses.

**WARNING**

Do not disconnect product water hose. Water is under pressure and will discharge rapidly.

Table 3-2. Troubleshooting (ROWPU) (continued)

---

**MALFUNCTION**  
**TEST OR INSPECTION**  
**CORRECTIVE ACTION**

---

- b Check TDS sample from each R.O. vessel using TDS meter without range extender (para.2-32c(5)).
- c. Use these findings to make a chart like the following:

R.O. Vessel	TDS (ppm)
1 (TOP)	600
2	900
3	1100
4 (Bottom)	1400

**NOTE**

The numbers on this chart are examples only. Yours may vary.

- d. Examine pattern of chart TDS should get -larger from top to bottom.
  - (1) If any R.O vessel does not follow this pattern, there is something wrong inside; disassemble the faulty vessel and replace defective items (see para 3-4).
  - (2) If R.O vessels all follow this pattern, proceed to Step 2.

Step 2. Check product water flow from each R.O vessel:

- a. Use same method as in Step 1 to collect water sample, but this time measure the time in minutes it takes to fill a3gallon bucket with product water from each vessel. Divide 3 by the number of minutes.
- b. Make a chart like the following:

R.O Vessel	FLOW (gpm)
1 (Top)	4
2	3
3	2
4 (Bottom)	1

Table 3-2. Troubleshooting (ROWPU) (continued)

<b>MALFUNCTION</b>	<b>TEST OR INSPECTION</b>	<b>CORRECTIVE ACTION</b>
		<p>c. Examine your chart for a similar pattern Flow should get smaller from top to bottom.</p> <p>(1) If any R.O vessel does not follow this pattern, disassemble that vessel and replace defective items (para.34).</p> <p>(2) If all vessels follow this pattern, notify unit maintenance to check for defective PRODUCT FLOW indicator.</p>
<b>6. R.O PRESSURE PSIG GOES ABOVE 960 PSI IN SALTWATER OPERATION, 500 IN FRESH OR BRACKISH WATER OPERATION.</b>		<p>Step 1. Check TDS of product water (para.2-32c(4)).</p> <p>a. If TDS over 1500 ppm, shut down ROWPU in normal manner (para.2-29) and clean R.O elements (para.2-28).</p> <p>b. If TDS below or at 1500 ppm, notify unit maintenance of possible defective gage.</p>
<b>7. BACKWASH PUMP RUNS CONTINUOUSLY.</b>		<p>Step 1. Check position of R.O ELEMENT CLEANING switch Switch must be off except during R.O element cleaning.</p> <p>Turn ELEMENT CLEANING switch to OFF position.</p> <p>Step 2. Notify unit maintenance to troubleshoot BACKWASH TIMER and its electrical wires.</p>
<b>8. BACKWASH WATER FLOW READING DROPS TO NEAR ZERO DURING BACKWASH OPERATION; BACKWASH PUMP LAMP IS ON.</b>		<p>Step 1. Check for closed or clogged valve on tank.</p> <p>a. Open closed valve by turning handle fully to the left until it stops (counter- clockwise).</p> <p>b. Clean clogged valve.</p> <p>Step 2. Check for clogged strainer or BACKWASH PUMP suction opening (para.36).</p> <p>a. Flush strainer with product water to remove debris.</p> <p>b. Remove debris from suction opening.</p>

Table 3-2. Troubleshooting (ROWPU) (continued)

<b>MALFUNCTION</b>	<b>TEST OR INSPECTION</b>	<b>CORRECTIVE ACTION</b>
	Step 3. Check level of water in backwash water tank.	
		<b>NOTE</b>
		There is a period of about 15 seconds when the flow gage will drop to "0" before returning to a normal reading This is normal.
		If water level is below backwash pump intake, immediately shut off backwash pump Patch any leaks in backwash water tank (para.3-8) Fill tank with raw water and continue backwash operation.
	Step 4. Check for leaking hose.	
		Replace defective hose.
<b>9.</b>	<b>DISTRIBUTION NOZZLE DELIVERS LITTLE OR NO PRODUCT WATER; DISTRIBUTION PUMP LAMP IS ON.</b>	
	Step 1. Check for water level below distribution pump intake in product water tank.	
		a. Patch any leaks in product water tanks.
		b. Continue operations to produce product water.
	Step 2. Check for loose hose connections or leaking hose.	
		a. Tighten loose connections.
		b. Replace leaking hose.
	Step 3. Check distribution nozzle for broken parts or inoperative handle.	
		Replace defective distribution nozzle.
<b>10.</b>	<b>PUMP LAMP ON CONTROL BOX ASSEMBLY DOES NOT LIGHT WHEN SWITCH IS SET TO START.</b>	
		<b>NOTE</b>
		Step 1 applies only to normal start of the raw water pump If other pump lamps do not light when started in proper order, go to step 2.
	Step 1. Ensure the EMERGENCY STOP button is pulled out.	
		Pull EMERGENCY STOP button out.

Table 3-2. Troubleshooting (ROWPU) (continued)

MALFUNCTION	TEST OR INSPECTION	CORRECTIVE ACTION
	Step 2.	Check to see if ROWPU is receiving power from power source R.O pump LOW PRESSURE LAMP should be on and panel light should work if ROWPU is receiving power. <ol style="list-style-type: none"> <li>Make sure power source is securely plugged into junction box.</li> <li>Troubleshoot power source using applicable manual.</li> </ol>
	Step 3.	Check to see if associated pump is operating For R.O pump, see if sheave is turning; for other pumps, rest a hand lightly on the motor casing to feel for motor vibrations, check for correct pump rotation. <ol style="list-style-type: none"> <li>If motor is running, replace panel light bulb (para.3-10).</li> </ol>

**NOTE**

If new bulb does not light, notify unit maintenance to troubleshoot lamp socket and wiring.

- If motor is not running, go to step 4.

**WARNING**

Electric shock can cause severe injury or death. Do not touch anything in the junction box except the circuit breaker handle.

Step 4. Check circuit breakers.

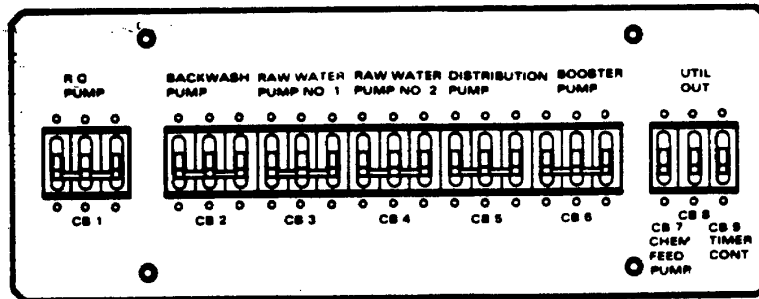

- Reset circuit breaker.
- Attempt to start pump.
- If pump will not start, notify unit maintenance.

Table 3-2. Troubleshooting (ROWPU) (continued)

<b>MALFUNCTION</b>	<b>TEST OR INSPECTION</b>	<b>CORRECTIVE ACTION</b>
<b>11. R.O PUMP SHUTS DOWN BY ITSELF; R.O PUMP LOW PRESSURE LAMP COMES ON.</b>		
	Step 1.	Check to see if booster pump is operating Rest hand lightly on motor casing to feel for vibrations. <ul style="list-style-type: none"><li>a. If pump is not operating, reset circuit breaker if necessary and try to restart pump If pump will not start, notify unit maintenance.</li><li>b. If booster pump is operating, check for clockwise rotation (from fan end).</li></ul>
	Step 2.	Check to see if cartridge filter gage reads over 20 psid. If over 20 psid, change cartridge filter tube elements (para.3-5).
	Step 3.	Check RAW WATER gage for normal flow. <ul style="list-style-type: none"><li>a. If low flow exists, move raw water pump closer to source.</li><li>b. If raw water flow is normal, go to step 4.</li></ul>
	Step 4.	Check to see if MULTIMEDIA FILTER gage has risen 5 psid over reading at startup. <ul style="list-style-type: none"><li>a. If yes, backwash multimedia filter (para.2-26).</li><li>b. If no, go to step 5.</li></ul>
	Step 5.	Make turbidity test of water taken from DRAIN NO 1 CARTRIDGE FILTER valve (fig 2-41). <ul style="list-style-type: none"><li>a. If water is turbid, shut down ROWPU in normal manner (para.2-31) and change cartridge filter elements (para.3-5).</li><li>b. If water is clear, notify unit maintenance.</li></ul>
<b>12. R.O PUMP SHUTS DOWN AUTOMATICALLY; R.O PUMP HIGH PRESSURE LAMP GOES ON.</b>		

**CAUTION**

If HIGH PRESSURE RELIEF VALVE did not activate before R.O PUMP HIGH PRESSURE switch, notify unit maintenance.

Table 3-2. Troubleshooting (ROWPU) (continued)

<b>MALFUNCTION</b>	<b>TEST OR INSPECTION</b>	<b>CORRECTIVE ACTION</b>
	Step 1. Check to see if R.O PRESSURE PSI gage is over 1150 psi.	
	a. Clean R.O elements (para.2-29) then attempt to restart R.O pump.	
	b. If R.O PUMP RESET switch does not turn off R.O PUMP HIGH PRESSURE lamp, there may be a defective switch Notify unit maintenance.	
<b>13. BACKWASH PUMP DOES NOT START WHEN START BACKWASH SWITCH IS SET TO START.</b>		
	Step 1. Check that INTERNAL INDICATOR knob is in SERVICE position (view 1, fig 2-74).	
	Press RESET button to ensure knob is in SERVICE position.	
	<b>NOTE</b>	
	If backwash pump still does not start, filter can be manually backwashed.	
	Step 2. Manually backwash multimedia filter as follows: -	
	a. Turn INTERNAL INDICATOR knob counterclockwise to BACKWASH position. Backwash should start.	
	<b>NOTE</b>	
	Allow filter to backwash for 10 minutes.	
	b. After 10 minutes of backwashing, turn knob counterclockwise to C/R (conditioned rinse) position.	
	<b>NOTE</b>	
	Allow filter to rinse for 2 minutes.	
	c. After 2 minutes of conditioned rinse, turn knob counterclockwise to SERVICE position Backwash is now complete.	
	d. Report defective timer to unit maintenance.	
<b>14. MULTIMEDIA FILTER VENT LINE DOESN'T DISCHARGE WATER.</b>		
	Step 1. Check vent line for obstruction.	
	Remove obstructions from vent line.	

Table 3-2. Troubleshooting (ROWPU) (continued)

<b>MALFUNCTION</b>	<b>TEST OR INSPECTION</b>	<b>CORRECTIVE ACTION</b>
<b>15. CHEMICAL FEED PUMP FAILS TO PRIME.</b>		
	Step 1. If pump fails to prime after setting control knob to max 8.5	Check the plastic suction line from the container to the pump.
	a.	If water level in suction tube does not reach the pump body or the water is not passing through the suction or discharge ball valves, disconnect the suction and discharge tubes from the valves.
	b.	Unscrew tubing nut from pump head Remove four hex-head capscrews from diaphragm body Inspect for and remove any foreign material between ball and valve seat.
	c.	Assemble valve parts and reconnect suction and discharge tubes.
<b>16. PRODUCT WATER TOTAL DISSOLVED SOLIDS (TDS) LEVEL IS ABOVE 1500 PPM.</b>		
	Step 1. Check product water from each pressure vessel as follows:	
	a.	Start up ROWPU as normal (para.2-25).
	b.	Adjust R.O PRESSURE to 960 psig for seawater feed or 500 psig for fresh/brackish water feed Collect a sample of product water in a clean container and measure TDS with TDS meter (para.2-32) Record value.
	c.	Open REGULATE PRODUCT WATER valve fully Product water flow should decrease to zero.
	d.	If sample valves are available, use them to collect sample product water from each vessel.
	e.	Using clean containers, collect a sample of product water from each end of R.O. Vessel 1 Be sure to rinse each container twice with sample water before collecting sample Mark container appropriately as front or rear.
	f.	Open REGULATE PRODUCT WATER valve fully Product water flow should decrease to zero at product water flow meter and Vessel 1 stub tubes.
	g.	Measure TDS of each product water sample using the TDS meter (para.2-32).
	h.	Based on the TDS measurements of the collected samples, one of the following four conditions can exist:



Table 3-2. Troubleshooting (ROWPU) (continued)

MALFUNCTION			
TEST OR INSPECTION			
CORRECTIVE ACTION			
CONDITION	MEASURED TDS		REAR CAUSE
	FRONT SAMPLE	SAMPLE	
1	High		Normal Leak At Front End-Connector O-Rings*
2	Normal		High Leak At Rear End-Connector O-Rings*
3	High		High Leak At Front And Rear End-Connector O-Rings and/or Element Interconnector O-Rings*
* Condition could also be caused by defective R.O. element			

**Condition 1:** Remove front end cap and end-connector and check condition, lubrication, and size of 0-rings Replace damaged or wrong-size 0-ring(s), lubricating 0-rings with lubricant found in Storage Box No.2 before installation. **Carefully** reinstall end-connector and end cap per para.3-4h.

**Condition 2:** Remove rear end cap and end-connector and check condition, lubrication, and size of 0rings Replace damaged or wrong-size 0-ring(s), lubricating 0-rings with lubricant found in Storage Box No 2 before installation. **Carefully** reinstall end-connector and end cap per para.3-4h.

**Condition 3:** Remove the R.O elements from the pressure vessel per para.3-4 Check condition, lubrication, and size of all 0-rings Replace damaged or wrong-size 0-ring(s), lubricating 0-rings with lubricant found in Storage Box No 2 before installation Carefully install elements and end caps per para.3-4h.

i. Adjust R.O PRESSURE to 800 psig (seawater) or 500 psig (brackish water).

j. For each R.O vessel in which 0-rings were inspected, collect a sample of product water from each end of vessel, rinsing each container twice with sample water before collecting sample Do one vessel at a time Mark container appropriately as front or rear.

k. Open REGULATOR PRODUCT WATER valve fully.

Table 3-2. Troubleshooting (ROWPU) (continued)

---

MALFUNCTION	TEST OR INSPECTION	CORRECTIVE ACTION
	l. Measure TDS of each product water sample (para.2-32c(5) If one or both samples are still high, leaky O-rings or faulty (cracked) connectors may still be present, or one or both R.O elements may be faulty Depending upon availability of time, either repeat steps a through l or replace the elements (para. 3-4).	
	m. Resume normal operation.	
Step 2. R.O elements may be scaled or fouled.		Clean R.O elements (para. 2-28).

---

### SECTION III. MAINTENANCE PROCEDURES

**3-3. INTRODUCTION.** This section provides maintenance procedures to be performed by the operator.

**3-4. CHANGING R.O. ELEMENTS.**

a. General. The R.O. elements are replaced any time TDS of product water exceeds 1500 parts per million and cannot be corrected by using procedures described in item 17, Table 3-2, Troubleshooting. Each R.O. vessel contains two R.O. elements.

**CAUTION**

If removing end caps from more than one R.O. vessel, mark end caps with pencil or chalk to ensure they are replaced on correct vessel and correct side.

Shutdown ROWPU and relieve all pressure before removing the R.O. element, or loosening any parts of the R.O. pressure vessels.

**NOTE**

Some steps require two people.

b. Pre-removal Procedures.

- (1) Shut the ROWPU down normally (para. 2-31).
- (2) Open all R.O. vents, drains, and valves (fig. 2-41 and 2-42).
- (3) Remove strainer and hose from water source.

**CAUTION**

To reduce chances of leaks, mark end caps and vessel (alignment marks) with chalk or pencil so that end caps are installed in the same position.

**LEGEND**

1. Hose Clamp
2. Tubing
3. Nut
4. Bolt
5. Clamp
6. Bushing
7. Elbow
8. Nut
9. Washer
10. End Cap
11. Puller Bolts
12. Pressure Tube
13. Adapter

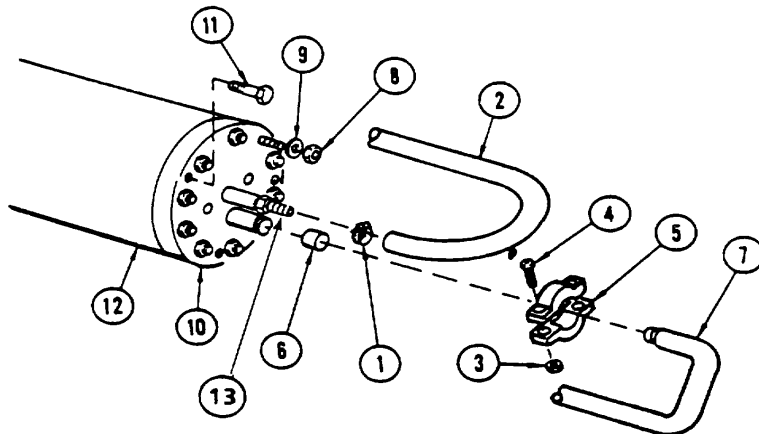

Figure 3-1. R.O. Vessel End Cap Assembly

c. End Cap Assembly (Refer to fig. 3-1).

- (1) Loosen hose clamp (1) and remove tubing (2) from end cap (10).
- (2) Remove nut (3), bolt (4), clamp (5), and bushing (6) from elbow (7).
- (3) Swing elbow (7) away from end cap (10).
- (4) Remove nuts (8) and washers (9) from end cap (10).

**CAUTION**

Use extreme caution when separating end cap from vessel. Vessel studs and seal are easily damaged.

(5) Gently and carefully insert flat-tip screwdriver between vessel and end cap. Slowly separate end cap from vessel.

(6) Repeat steps (1) through (5) for opposite end cap.

d. Element Puller Assembly (Refer to fig. 3-2).

- (1) Assemble element puller by screwing together the puller rod (1) and puller rod handle (2).

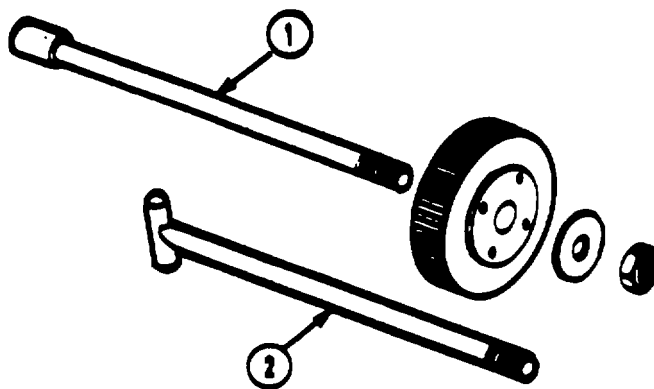

LEGEND:

1. Puller Rod
2. Puller Rod Handle

*Figure 3-2. R.O. Vessel Element Puller*

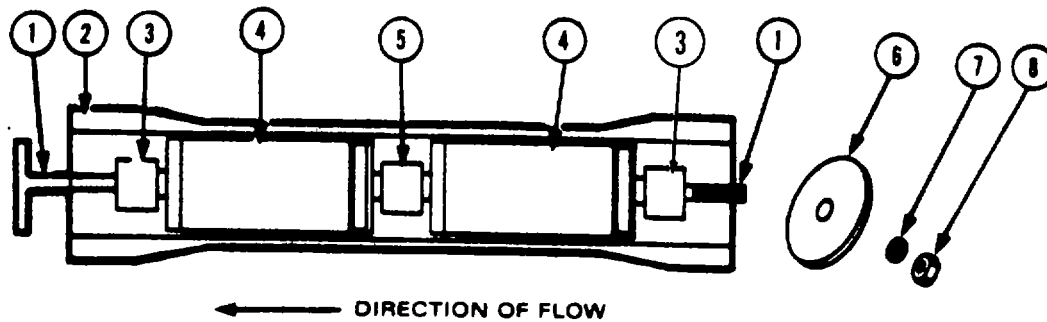

LEGEND:

- |                               |                         |
|-------------------------------|-------------------------|
| 1. Element Puller (Assembled) | 5. Interconnector       |
| 2. R.O. Vessel                | 6. Element Puller Plate |
| 3. End Connector              | 7. Flat Washer          |
| 4. R.O. Elements              | 8. Nut                  |

Figure 3-3. R.O. Vessel Element Puller Assembly

**NOTE**

If possible, remove elements in direction of flow. Because of obstruction by generator, Army users must remove and install elements from trailer hitch end.

MC Model 0996108001 users should remove top and second-from-bottom elements from R.O. pump end and install from chemical feed pump end. Remove the bottom and second-from-top elements from chemical feed pump end and install from R.O. pump end.

(2) Refer now to fig. 3-3. From the front of the ROWPU, insert element puller (1) into R.O. vessel (2). Push puller through end connector (3), through the product water tubes of the two R.O. elements (4), and through the interconnector (5) between the two R.O. elements.

(3) Place element puller plate (6) on assembled element puller (1) and secure with flat washer (7) and nut (8).

(4) After inserting the element puller into the R.O. elements and attaching the element puller plate, the assembly will be as shown below (fig. 3-4).

e. Removal. (Refer to fig. 3-4).

(1) Slowly pull both R.O. elements (1) from R.O. vessel (2), while someone else supports assembly. Be careful to keep element puller centered in tube.

**NOTE**

Placing one hand on frame while pulling with the other hand may help to keep the element puller centered.

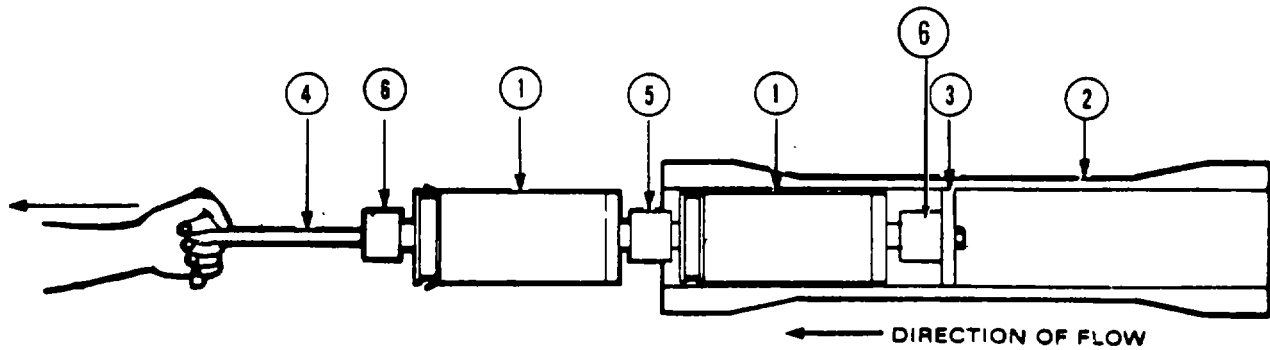

**LEGEND:**

- |                         |                   |
|-------------------------|-------------------|
| 1. R.O. Elements        | 4. Element Puller |
| 2. R.O. Vessel          | 5. Interconnector |
| 3. Element Puller Plate | 6. End Connector  |

*Figure 3-4. Pulling Element From R.O. Vessel*

(2) Disconnect the element puller plate (3) after both R.O. elements are removed. Pull element puller out of R.O. elements and end connector. With one person on either end of assembly, twist and pull elements apart.

f. Inspection.

- (1) Inspect inside R.O. vessels for nicks and gouges.
- (2) Check interconnector and both end connectors for deep scratches and cracks.
- (3) Check brine seals and O-rings for cracks and tears.

g. Cleaning.

- (1) Flush dirt from inside R.O. vessels using brine water.
- (2) Wipe any dirt from interconnector or end connectors using a clean cloth.

h. Installation. (Refer to fig. 3-5).

- (1) Lubricate O-rings with O-ring lubricant from Storage Box No. 2.

**NOTE**

There is a smaller and a bigger sized O-ring on the end connectors. The side of the end connector which will fit on end of R.O. element has a lip on the inside. This side of end connector has the bigger O-ring. The interconnector O-rings are the same size as the bigger end connector O-rings.

- (2) Install O-rings (1) and (3) in end connectors (2) and interconnector (5).

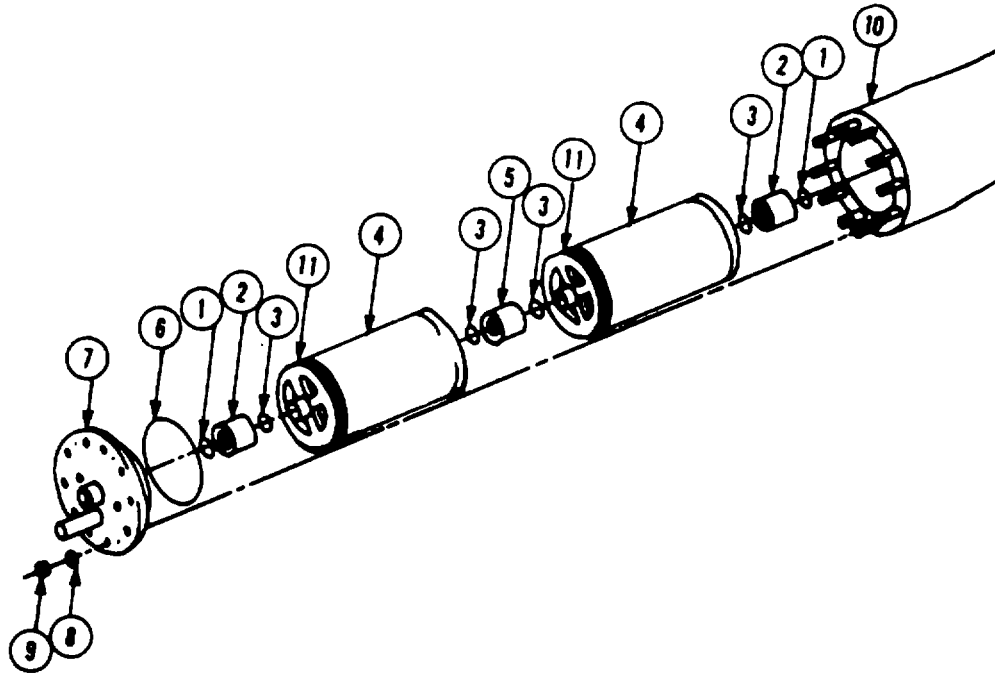

LEGEND:

- |    |                                       |     |                                |
|----|---------------------------------------|-----|--------------------------------|
| 1. | End Connect O-ring (1.680 In. O.D.)   | 6.  | End Cap O-ring (6.00 In. O.D.) |
| 2. | End Connector                         | 7.  | End Cap                        |
| 3. | Interconnector O-ring (1.756 In O.D.) | 8.  | Washer                         |
| 4. | R.O. Element                          | 9.  | Nut                            |
| 5. | Membrane Interconnector               | 10. | R.O. Vessel                    |
|    |                                       | 11. | Brine Seals                    |

Figure 3-5. R.O. Vessel (Exploded View)

**WARNING**

Some R.O. elements are packaged in sealed plastic bags with the protective chemical formaldehyde, which is poisonous; avoid fumes and keep away from eyes and mouth. Handle with extreme care. After handling, wash hands thoroughly with soap and water.

**CAUTION**

After removing R.O. element from sealed plastic bag, take care to keep element clean. Failure to do so will bring dust and dirt into R.O. elements and cause early element failure.

(3) Remove new R.O. element (4) from sealed plastic bag.

(4) Refer now to fig. 3-6, and install brine seal (1) in groove of R.O. element (2) making sure open end faces R.O. pump end of ROWPU or opposite end of the direction of flow.

**NOTE**

MC Model 0996108001 top and second-from-bottom vessels have reverse flow direction. Open end of brine seal should face chemical feed pump end of ROWPU.

(5) Insert by hand the first R.O. element (2) into R.O. vessel (3) until brine seal (1) touches end of R.O. vessel.

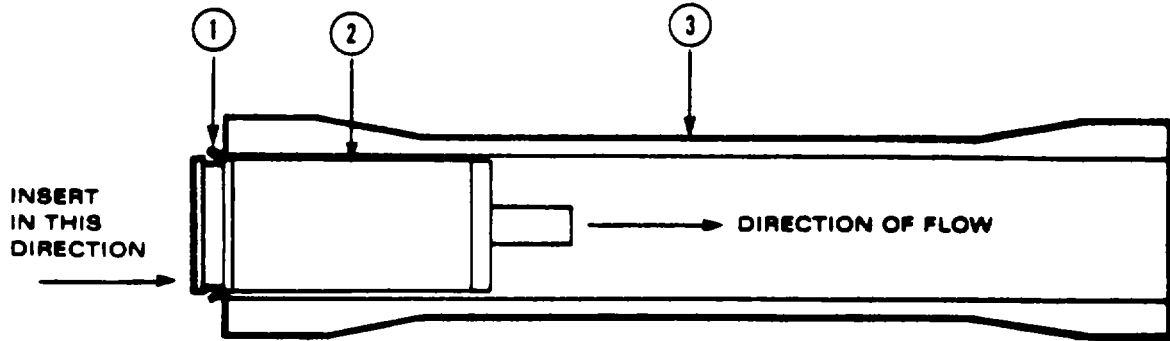

**LEGEND:**

- 1. Brine Seal
- 2. R.O. Element
- 3. R.O. Vessel

**NOTE**

(MC) Direction of flow is indicated on the side of each element.

*Figure 3-6. Element Replacement*

(6) Refer now to fig. 3-7. Place interconnector (1) on product water tube (2) of first R.O. element (3).

**NOTE**

Do not confuse interconnector with end connectors. End connectors have a lip on the outside.



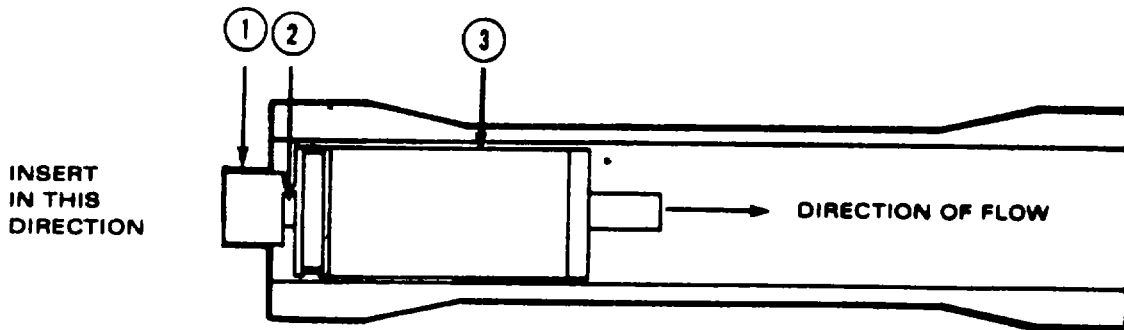

LEGEND:

1. Interconnector
2. Product Water Tube
3. R.O. Element

*Figure 3-7. Element Replacement*

(7) Remove second R.O. element from sealed plastic bag.

(8) Install brine seal (1) into groove of second R.O. element. Make sure that the open end of the seal is opposite the direction of flow.

(9) Refer now to fig. 3-8. Insert product water tube (2) of the second R.O. element into interconnector (3).

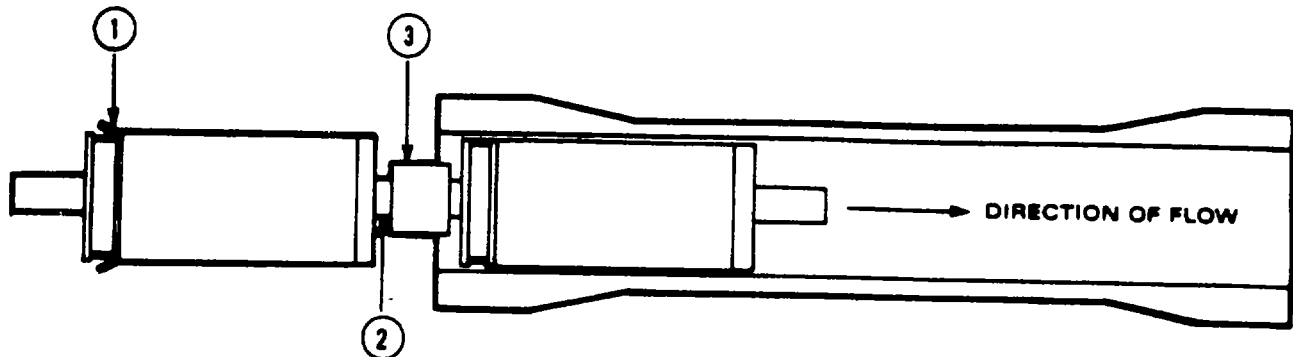

LEGEND:

1. Brine Seal
2. Product Water Tube
3. Interconnector

*Figure 3-8. Element Replacement*

(10) Refer now to fig. 3-9. Slide both R.O. elements (1) and interconnector (2) into R.O. vessel (3) until they are centered in the vessel.

(11) Place end connectors (4) on both ends of product water tubes of R.O. elements. Join them to product water tubes of end caps.

(12) Align end caps with matchmark on R.O. vessel.

(13) Press end caps onto studs.

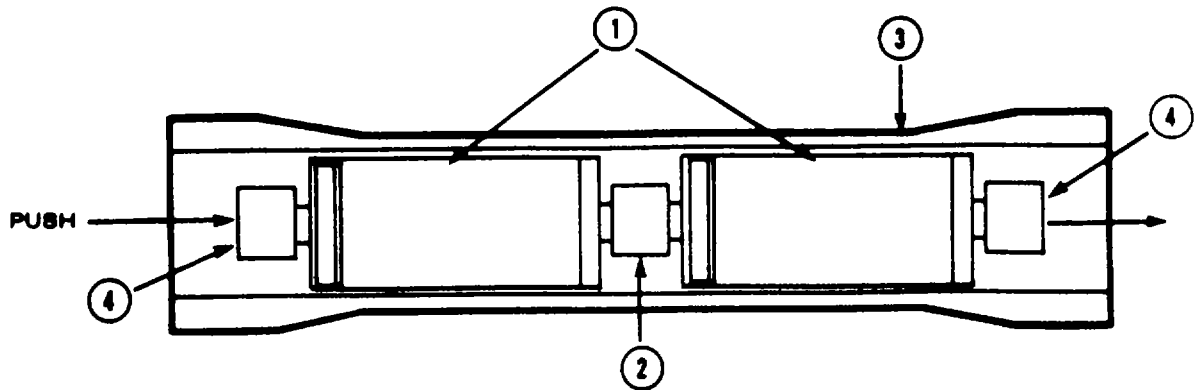

LEGEND:

- 1. R.O. Elements
- 2. Interconnector
- 3. R.O. Vessel
- 4. End Connector

Figure 3-9. Element Replacement

(14) Place 10 washers and nuts onto studs.

**CAUTION**

65 in. lb (5.4 ft. lb) is maximum torque for end cap nuts. Do not exceed this torque.

(15) Slowly and evenly tighten nuts until handtight (snug). Never turn one nut more than two turns at a time. Once handtightened, evenly tighten each nut 1/8 turn with wrench.

(16) Reconnect pipes to R.O. vessel (fig. 3-1).

- (a) Slide hose clamp (1) over tubing (2). Place tubing (2) and clamp (1) over adapter (13) and tighten clamp (1)
- (b) Place bushing (6) back on pipe.
- (c) Swing elbow (7) back into place and put bushing (6) over elbow (7).
- (d) Put clamp (5) over bushing (6).
- (e) Put bolts (4) into clamps (5).
- (f) Put nuts (3) on bolts (4) and tighten.

(17) Operate ROWPU (para. 2-25) and observe for leaks.

**3-5. CHANGING CARTRIDGE FILTER TUBE ELEMENTS.** Refer to fig. 3-10.

a. Description. The cartridge filter contains eight filter tube elements. Cartridge filter tube elements should be changed when CARTRIDGE FILTER gage differential pressure rises above 20 psid.

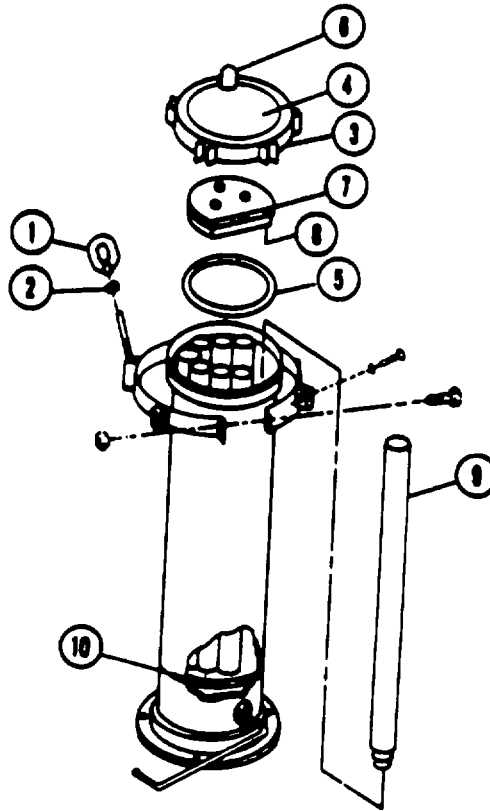

LEGEND:

1. Eye Nut
2. Washer
3. Bracket
4. Filter Cover
5. O-ring
6. Vent
7. Compression Plate
8. Tube Guides
9. Filter Tube
10. Sump Seat

Figure 3-10. Cartridge Filter Assembly (Model Nos. 0996108001 and 0996109001)

b. Removal.

- (1) Shut down ROWPU in the normal manner (see para. 2-31).
- (2) Open VENT CARTRIDGE FILTER valve (fig. 2-58).
- (3) Open DRAIN NO. 1 CARTRIDGE FILTER valve fully (para. 2-12).
- (4) Loosen six eyenuts (1) and washers (2) from the cover brackets (3).
- (5) Remove quick disconnect from vent (6) and lift cover (4), remove O-ring (5) and hose on vent (6). Check O-ring for cracks, breaks and hardening. Replace O-ring if damaged.
- (6) Remove compression plate (7) with tube guides (8).
- (7) Remove the eight filter tubes (9) and discard.

c. Installation.

- (1) Install eight new filter tubes (9) making sure that the tube seat is in the guides on the sump seat (10).

- (2) Replace compression plate (7) making sure that the tube guides (8) seat in the filter tubes (9).
- (3) Replace O-ring (5) and filter cover (4).

**CAUTION**

Ensure all filter tubes are properly seated before tightening eyenuts.

- (4) Slide eyenuts (1) with washers (2) into cover brackets (3) and tighten in the order shown (fig. 3-11).
- (5) Attach quick disconnect to vent (6). Operate ROWPU and check for leaks.

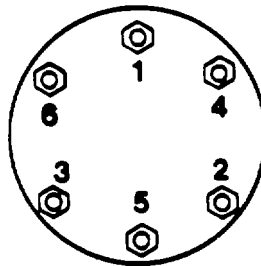

*Figure 3-11. Cartridge Filter End Cover (Eye Nut Tightening Sequence)*

**3-6. BACKWASH PUMP STRAINER** (refer to fig. 3-12).

a. Removal.

- (1) Shut down ROWPU in normal manner (para. 2-31).
- (2) Loosen T-handle screw assembly (1) by turning to the left to release pressure on the strainer cap (4).
- (3) Loosen the two bolts (2) and swing the yoke (3) and the T-handle out of the way as shown.
- (4) Using the two ears on the strainer cap (4), twist back and forth until it loosens and lifts off the strainer housing (8).
- (5) Remove the gasket (5) and discard if it is damaged or unserviceable.
- (6) Lift handle on strainer screen (6) and remove screen from the strainer housing (8).
- (7) Remove drain plug (7) from the bottom of strainer housing.

b. Cleaning.

- (1) Flush strainer housing (8) with product water to remove foreign matter and dirt.
- (2) Flush strainer screen (6) with product water. Make sure that all the holes in the screen are open.

- (3) Clean strainer screen.
- (4) Remove dirt or corrosion from cap (4) and strainer housing (8).

LEGEND:

- 1 T-Handle
- 2 Bolts
- 3 Yoke
- 4 Strainer Cap
- 5 Gasket
- 6 Strainer Screen
- 7 Drain Plug
- 8 Strainer Housing

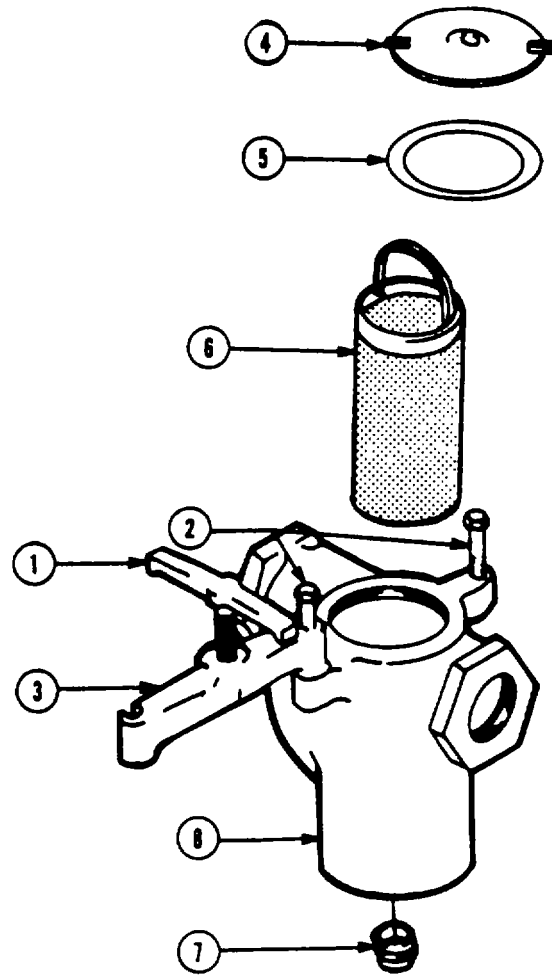

Figure 3-12. Backwash Pump Strainer

c. Installation.

- (1) Install drain plug (7) in bottom of strainer housing (8).
- (2) Install the strainer screen (6).
- (3) Install the gasket (5) and strainer cap (4) on top of the strainer housing.
- (4) Swing yoke (3) and T-handle screw assembly (1) back into position under the bolts (2).
- (5) Recenter the strainer cap (4) making sure the gasket is positioned correctly.
- (6) Tighten both bolts.
- (7) Tighten T-handle (1).

### 3-7. RUPTURE DISC.

#### **CAUTION**

Continued operation after the rupture disc opens could damage the ROWPU. Immediately shut off the ROWPU with the EMERGENCY STOP button (fig. 2-50) and open the REGULATE PRODUCT FLOW valve (3, fig. 2-67) all the way.

a. General. The rupture disc is a safety device for the R.O. Pump Assembly. If the pressure ever reaches 1425 psi on the R.O. PRESSURE PSI gage, the rupture disc tears open relieving the pressure. The disc is mounted in a screw-type mount body on top of the R.O. pump discharge pipe. Replace the rupture disc after it blows, and before starting the ROWPU again.

b. Removal.

- (1) Remove holddown screw (1) from body (4).
- (2) Remove holddown ring (2).
- (3) Remove ruptured disc (3) and discard.

#### LEGEND

- |   |                |
|---|----------------|
| 1 | Holddown Screw |
| 2 | Holddown Ring  |
| 3 | Rupture Disc   |
| 4 | Body           |

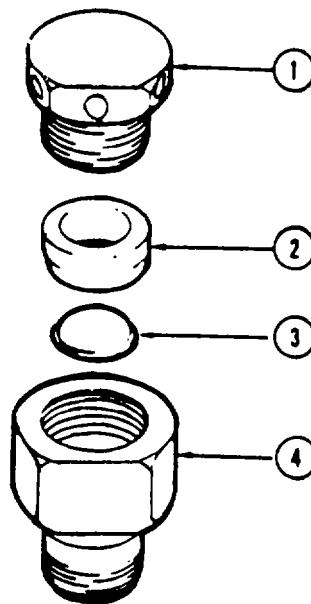

Figure 3-13. R.O. Pump Rupture Disc and Holder

c. Installation.

- (1) Place the side of new rupture disc (3) that curves upward toward the top.
- (2) Insert it into body (4).

- (3) Replace holddown ring (2).

**CAUTION**

To avoid damaging rupture disc, do NOT overtighten holddown screw.

- (4) Reinsert holddown screw (1). Tighten until hand tight (snug), then tighten 1/8 turn with wrench.

**3-8. REPAIR OF CANVAS PRODUCT WATER AND BRINE WATER TANKS**

a. General. Canvas tanks with rubber backing are used to store product water and brine water. Sometimes these tanks may be cut or punctured. Tanks then leak and must be repaired.

**CAUTION**

To avoid possible damage, the site should be free from stones or sharp sticks, be fairly smooth, and covered with the ground cloth before the tank is placed on ground.

b. Repair. If a tank is punctured, use the oval sealing clamps supplied in the repair kit to make temporary repairs.

**NOTE**

The tank does not need to be drained to make these repairs.

(1) Determine the size of sealing clamp needed. If the hole or slit is up to 2 1/2 inches (6.35 cm) in length, use the 3-inch (7.62 cm) sealing clamp. If the hole or slit is 2 1/2 to 4 inches (6.35 cm to 10.16 cm) in length, use the 5-inch (12.7 cm) sealing clamp.

(2) If necessary, carefully enlarge the slit to slip the narrow side of the inside clamp through.

(3) Slip the inside clamp through the slit in the tank and rotate it to line up with the slit.

(4) Rotate the outside clamp to line up with the inside clamp.

(5) Center both clamps over the slit, pull them together with the rope, and tighten the wing nut as tight as possible with your fingers.

**3-9. CALIBRATION AND REPAIR OF PORTABLE TDS METER**

**CAUTION**

The TDS meter is an accurate meter. With the exception of calibrating meter or replacing meter battery, never attempt to service or modify instrument, nor allow it to get wet since moisture will damage the meter.

a. Calibration. Perform a calibration check in accordance with para. 2-32c(4) each time before using TDS meter. Whenever switching to or from seawater sources, meter must be recalibrated in accordance with para. 2-32c(2) or para. 2-32c(3).

b. Battery Replacement (fig. 3-14):

- (1) Remove bottom plate.
- (2) Disconnect leads from battery.
- (3) Install new battery and connect leads.
- (4) Install bottom plate.
- (5) Check calibration in accordance with para. 2-32c.
- (6) If reading cannot be adjusted after replacing battery, replace the TDS meter.

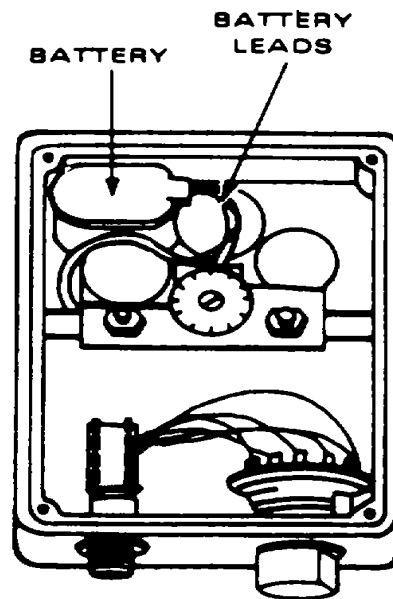

Figure 3-14. Total Dissolved Solids (TDS) Meter (Portable) Battery Replacement

**3-10. REPLACE SWITCH INDICATOR LAMPS** (refer to fig. 3-15)

a. Removal.

- (1) Unscrew lens cap (1).
- (2) Twist bulb (2) to left and push in at the same time using lamp puller in Storage Box No. 2.

**CAUTION**

Be careful not to lose the cupped gasket washer. Without this gasket, you can break lens when tightening, and dampness will fog lens.



LEGEND

1. Lens Cap
2. Lamp Bulb
3. Gasket Washer
4. Lamp Base Holder

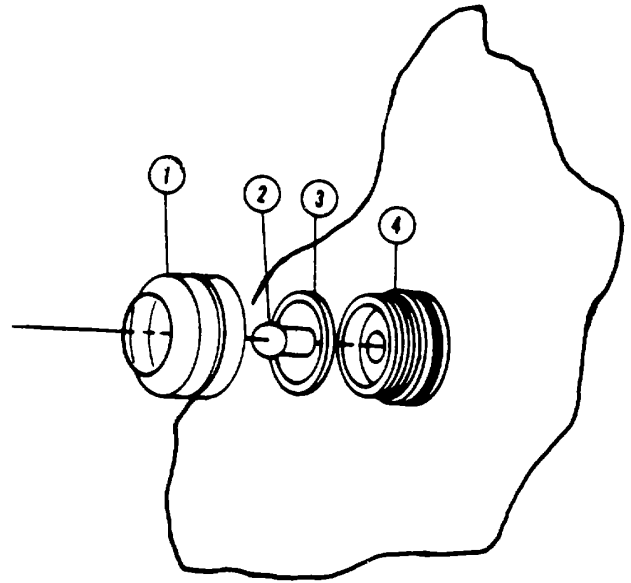

*Figure 3-15. Switch Indicator Lamp Replacement*

b. Installation.

- (1) Replace bulb (2) with lamp puller in Storage Box No. 2.
- (2) Cover the lamp base holder (4) with gasket washer (3).

**NOTE**

Clean lens cap before reassembly.

- (3) Screw on lens cap (1).
- (4) Test new lamp using the TEST INDICATOR LIGHTS switch on left side of control box.

**3-11. REPLACING LAMP IN THE PANEL LIGHT** (refer to fig. 3-16)

a. Removal.

- (1) Using flat-tip screwdriver, loosen setscrew (1), observing position of shield.
- (2) With your fingers, unscrew guard (2), lens (3), and bulb (4) from lamp base (5).

**NOTE**

Lens must be cleaned before installation.

LEGEND

1. Setscrew
2. Guard
3. Lens
4. Bulb
5. Lamp Base

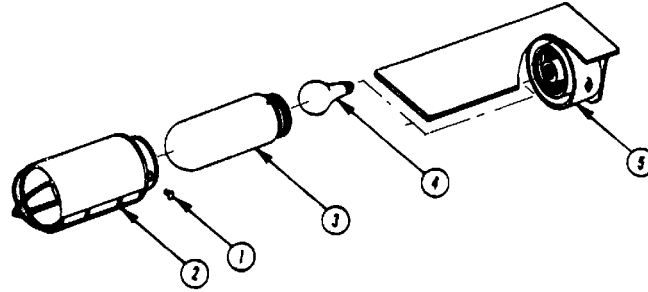

*Figure 3-16. Panel Lamp Replacement*

b. Installation.

- (1) With your fingers, screw bulb (4), lens (3), and guard (2) into lamp base (5).
- (2) Position shield in same position it was in before you removed it.

**3-31/(3-32 blank)**

## CHAPTER 4

### MAINTENANCE OF AUXILIARY EQUIPMENT

**4-1. POWER SOURCE. (ARMY).** Maintenance of Army generator set is covered in TM 5- 6115-465-12 for NSN 611500-118-1240.

(MC) Marine Corps users will refer to applicable publications referencing power sources used by that organization.

**4-1/(4-2 blank)**

**APPENDIX A**

**REFERENCES**

**A-1. SCOPE**

This appendix lists all forms, field manuals, and technical manuals, referenced in this manual.

**A-2. FORMS**

Consolidated Engineer Equipment Operation Log and Service Record .....	NAVMC 10524
Equipment Daily or Monthly Log.....	DA Form 2408-1
Equipment Inspection and Maintenance Work Sheet .....	DA Form 2404
Maintenance Request.....	DA Form 2407
Quality Deficiency Report.....	SF 368
Recommended Changes to DA Publications .....	DA Form 2028-2
Recommended Changes to Technical Publications.....	NAVMC 10772

**A-3. TECHNICAL MANUALS**

Equipment Record Procedures .....	TM 4700-15/1
Hand Receipt Covering End Item/Components of End Item (COEI), Basic Issue Items (BI), and Additional Authorization List Items (AAL) for Water Purification Unit, Reverse Osmosis .....	TM 10-4610-239-10-HR
Operator and Organizational Maintenance Manual; Generator Set, Diesel Driven, Tactical Skid Mtd. 30 kW, 3 Phase, 4 Wire, 120/208 and 240/416 Volts, NSN 6115-00-118-1240 (ARMY) .....	TM 5-6115-465-12

**A-4. MISCELLANEOUS**

The Army Maintenance Management Systems (TAMMS).....	DA PAM 738-750
Department of the Army Information Security Program .....	AR 380-5
Department of Navy Information and Personnel Security Program Regulation .....	OPNAVINST 5510.1
Lubrication Order.....	LO 10-4610-239-12
.....	LI 08580B-12
Identification and Distribution of Department of the Army Publications and Issue of Agency and Command Administrative Publications .....	AR 310-2
First Aid Manual.....	FM 21-11

Marine Corps Military Incentive Awards Program .....	MCO 1650.17
Stock List for ROWPU (MC) .....	SL 3-08580B
Supply Catalog (Army) .....	SC 4610-97-CL-E16

## APPENDIX B

### COMPONENTS OF END ITEM AND BASIC ISSUE ITEMS LISTS

#### SECTION I. INTRODUCTION

**B-1. SCOPE.** This appendix lists components of end item and basic issue items for the ROWPU to help you inventory items required for safe and efficient operation.

**B2. GENERAL.** The Components of End Item and Basic Issue Items Lists are divided into the following sections:

a. Section II. Components of End Item. This listing is for informational purposes only, and is not authority to requisition replacements. These items are part of the end item, but are removed and separately packaged for transportation or shipment. As part of the end item, these items must be with the end item whenever it is issued or transferred between property accounts. Illustrations are furnished to assist in identifying items.

b. Section III. Basic Issue Items. These are the minimum essential items required to place the ROWPU in operation, to operate it, and to perform emergency repairs. Although shipped separately packaged, BII must be with the shelter during operation and whenever it is transferred between property accounts. The illustrations will assist you with hard-to-identify items. This manual is your authority to request/requisition replacement BII, based on TOE/MTOE authorization of the end item.

#### **B-3. EXPLANATION OF COLUMNS**

The following provides an explanation of columns found in the tabular listings:

a. Column (1) - Illustration Number (Illus No.). This column indicates the number of the illustration in which the item is shown.

b. Column (2)-National Stock Number. Indicates the National stock number assigned to the item and will be used for requisitioning purposes.

c. Column (3) - Description. Indicates the Federal item name and, if required, a minimum description to identify and locate the item. The last line for each item indicates the CAGEC (in parentheses) followed by the part number.

d. Column (4) - Unit of Measure (U/M). Indicates the measure used in performing the actual operational/maintenance function. This measure is expressed by a two-character alphabetical abbreviation (e.g., ea, in, pr).

e. Column (5) - Quantity required (Qty Rqd). Indicates the quantity of the item authorized to be used with/on the equipment.

SECTION II. COMPONENTS OF END ITEM

(1) ILLUS NUMBER	(2) NATIONAL STOCK NUMBER	(3) DESCRIPTION, CAGEC and Part Number	(4) Usable On Code U/M	(5) QTY Reqd
1	4730-01-267-0001	Adapter Assembly, Female NPSH to Female Cam-Lock (97403) 13227E8836	EA	1
2	4730-00-088-9285	Adapter, Cam-Lock; 2-Inch, Female to 2 Inch NPT External Thread MS27026-11	EA	
3	4730-01-131-8245	Adapter, Hose: Brass; 2 Inch - 11-1/2 NPSH Internal One End; 1-1/2 Inch- 11-1/2 NPSH External Other End (97403) 13222E5277-1	EA	2
4		Adapter, Straight, Pipe to Hose (97403) 13228E3312-18	EA	4
5		Adapter, Straight, Pipe to Hose (97403) 13228E3312-19	EA	2
6	47300-0278-8271	Adapter, Straight, Pipe to Hose: Brass Pipe End 1-1/2 Inch - 11-1/2 NPT External; Hose End 1-1/2 Inch - 11-1/2 NPSH Internal; (81349) MIL-C-52404, Type XVI, Class B	EA	2
7	4730-00-277-6844	Adapter, Straight, Pipe to Hose: Brass; Pipe End 1-1/2 Inch- 11-1/2 NPT External; Hose End 1-1/2 NPSH External (81349) MIL-C-52404, Type XVI, Class C	EA	1
8	4730-00-277-6845	Adapter, Straight, Pipe to Hose: Brass; Pipe End 2 Inch - 11-1/2 NPT External; Hose End 2 Inch - 11-1/2 NPSH External: (81349) MILL-52404, Type XVI, Class C	EA	1
9	4730-01-088-1698	Adapter, Swivel, Hose: Brass; 2 Inch - 11-1/2 NPSH External One End; 1-1/2 Inch- 11-1/2 NPSH Internal Swivel Other End (97403) 13221 E8277	EA	1
10	4730-01-107-7630	Adapter, Swivel, Pipe to Hose: Brass; Pipe End 2 Inch - 11-1/2 NPT External; Hose End 2 Inch- 11-1/2 NPSH Internal: (97403) 13221E8290-2	EA	1

SECTION II. COMPONENTS OF END ITEM

(1) ILLUS NUMBER	(2) NATIONAL STOCK NUMBER	(3) DESCRIPTION, CAGEC and Part Number	(4) Usable On Code U/M	(5) QTY Reqd
11	4730-00-277-1873	Bushing, Pipe: Shoulder (96906) MS1 4315-20Y	EA	2
12	4730-01-353-2984	Coupling, Cam-Lock; 2 Inch Male to 2 Inch NPSH Internal Thread MS700954		
13		Coupling, Cam-Lock; 2 Inch Female to 2 Inch NPSH External Thread MS70096-4		
14	4730-00-432-7448	Coupling, Cam-Lock; 2 Inch Male to 1-1/2 Inch NPT External Thread MS4900-9		
15	7240-01-223-3439	Can Assembly, Chemical Feed, Chlorine: (97403) 13226E7990-4	EA	1
16	7240-01-224-2852	Can Assembly, Chemical Feed, Citric Acid: (97403) 13226E7990-3	EA	1
17	7240-01-223-3438	Can Assembly, Chemical Feed, Polymer: (97403) 13226E7990-1	EA	1
18	7240-01-223-3437	Can Assembly, Chemical Feed, Sodium Hex. EA (97403) 13226E7990-2	1	
19	4610-01-128-1844	Cartridge, Chemical Agent Removal; (97403) 13221 E8341-2	EA	1
20	461 0-01-116-0501	Cartridge, Radiological Contaminant Removal; No. D9001 (05852); (97403) 13221E8341-1	EA	1
21		Chest Assembly, Storage (97403) 13221 E8380-1	EA	1
22		Chest Assembly, Storage (97403) 13221 E8380-2	EA	1
23	4730-00-908-3194	Clamp, Hose; Low Pressure, Type 'F', (96406) MS 35842-11 (96906)	EA	6



Section II. COMPONENT OF END ITEM (continued)

(1) ILLUS NUMBER	(2) NATIONAL STOCK NUMBER	(3) DESCRIPTION, CAGEC and Part Number	(4) Usable On Code U/M	(5) QTY Reqd
24	4730-01-125-4456	Coupling, Pipe: Corrosion Resistant: (97403) 1321 8E0439-8	EA	1
25	4610-01-105-2075	Element, Reverse Osmosis, Spiral Wound (97403) 13226E2212	EA	8
26	4610-00-066-2478	Float, Figure 4, (81349) MIL-W-52482	EA	1
27	6115-00-118-1240	Generator Set, Diesel Engine Driven Tactical, Utility, Skid Mid, 30 kW, 3 phase, 4 Wire, 120/208 and 240/416 Volts, 50/60 Hertz (81349) MIL-G-52884/5	EA	1
28	4720-00-289-6123	Hose Assembly, Cotton, Rubber Lined: Single Jacket; Synthetic; 300 psi Test Pressure; Brass Coupling Each End, FED Spec WW-C-621, Type B1, Expansion Ring, Rocker Lug, Rigid External THD One End and Swivel Internal THD Other End; 1-1/2 Inch - 11-1/2 NPSH: 1-1/2 In ID: 25 Ft. Lg, Excluding Couplings; ZZ-H-451, Type I, Class B, Size 1-1/2, For Potable Water Use, (See PARA 3.4.1.1 of ZZ-H-451).	EA	6
29	4720-01-136-6564	Hose Assembly, Polyester, Rubber Lined: Single Jacket; Synthetic; 350 psi Test Pressure Brass Coupling Each End, FED Spec WW-C-621, Type B1, Expansion Ring, Rocker Lug, Rigid External THD One End and Swivel Internal THD Other End; 2 Inch -11-1/2 NPSH: 1 Inch ID; 25 Ft. L, Excluding Couplings; ZZ-H-451, Type III, Class B, Size 2, For General Water use.	EA	3
30	4720-00-202-8651	Hose Assembly, Rubber, Smooth Bore, Suction and Discharge, Wrapped Fabric Construction, Wire Reinforcement, 100 psi Test Pressure, Brass Coupling Each End, WW-C-624, Type B1, Expansion Ring, Rocker Lug, Rigid External THD One End and Swivel Internal THD Other End; 2 Inch -11-1/2 NPSH, 2 Inch ID; 10 Ft. Long Excluding Coupling; ZZ-H-561, Grade B, Style A, Class 1, Size 2, (General Water Use Inner Tube)	EA	3

Section II. COMPONENTS OF END ITEM (continued)

(1) ILLUS NUMBER	(2) NATIONAL STOCK NUMBER	(3) DESCRIPTION, CAGEC and Part Number	(4) Usable On Code U/M	(5) QTY Reqd
31	4720-00-202-6731	Hose Assembly, Rubber, Smooth Bore Suction and Discharge, Wrapped Fabric Construction, Wire Reinforcement, 100 psi Test Pressure, Brass Coupling Each End, WW-C-024, Type B1, Expansion Ring, Rocker Lug, Rigid External THD One End and Swivel Internal THD Other End; 1-1/2 Inch- 11-1/2 NPSH, 1-1/2 Inch ID; 10 Ft, Long Excluding Couplings; ZZ-H-561, Grade B, Style A, Class 2, Size 1-1/2, (Potable Water Use Inner Tube)	EA	9
32		Meter Assembly, Monitor, Dissolved Solids (97403) 13227E7585	EA	1
33	4930-00-902-4642	Nozzle, Fuel and Oil Servicing: Pistol Grip, Self-Closing; w/Integral Strainer; 1-1/2 Inch NPT, Internal Inlet; Rigid Spout; w/Reducing Bushing, Dust Cap, Strainer and Nozzle (81349) MIL-N-52110, Type I, Size 2	EA	1
34	4320-01-083-9863	Pump Assembly, Backwash (97403) 13222E5260	EA	1
35	4320- 01-083-9859	Pump Assembly, Distribution (97403) 13222E5265	EA	1
36	4320-01-084-2235	Pump Assembly, Raw Water (97403) 13222E5250	EA	2
37	7125-01-232-7686	Rack, Chemical Feed Can (97403) 13226E8331	EA	1
38	4730-01-133-1727	Reducer, Adapter; ½ NPT External X ¾ Hose Internal (27901) 61148	EA	2
39	4210-00-377-6521	Reducer, Hose; 2 Inch NPSH Internal Thread to 1-1/2 Inch NPSH Internal Thread MIL-C-52404, Type 15, Class A		
40	5975-01-053-3991	Rod, Ground: Three 3-Ft Sections; w/attachments; W-R-550, Type III, Class B	EA	1

Section II. COMPONENTS OF END ITEM (continued)

(1) ILLUS NUMBER	(2) NATIONAL STOCK NUMBER	(3) DESCRIPTION, CAGEC and Part Number	(4) Usable On Code U/M	(5) QTY Reqd
41	2540-01-115-1513	Step, Portable, (97403) 13221 E8342	EA	1
42	4730-00-684-4296	Strainer, Suction Hose: Brass; Cylindrical, (97403) 1 3228E8307	EA	1
43	5430-01- 170-6984	Tank, Assy Fabric, Collapsible: Water Storage, 3000 Gal; (81349) MIL-T-14398	EA	3
44	2330-01-226-0709	Trailer, Flatbed: 600 GPH ROWPU (97403) 13222E7100	EA	1
45	4720-01-132-0800	Tubing, Flexible, Reinforced; 80.00 Inch Lg (97403) 13221E8367-2	EA	3
46	4820-00-288-7568	Valve, Gate 1-1/2inch-11-1/2 NPT (81348) WWV-54	EA	1
47	4820-00-595-1847	Valve, Gate 2-11-1/2 NRT (81348) WWV-54	EA	1
48	4610-01-234-2190	Water Purification Unit, Skid Mid, TY III, (81349) MIL-W-52960	EA	1
49	4610-01-234-2196	Water Purification Unit, Trailer Mounted Type I: Reverse Osmosis, 600 GPH, (81349) MIL-W-52960	EA	1

Section II. COMPONENTS OF END ITEM (continued)

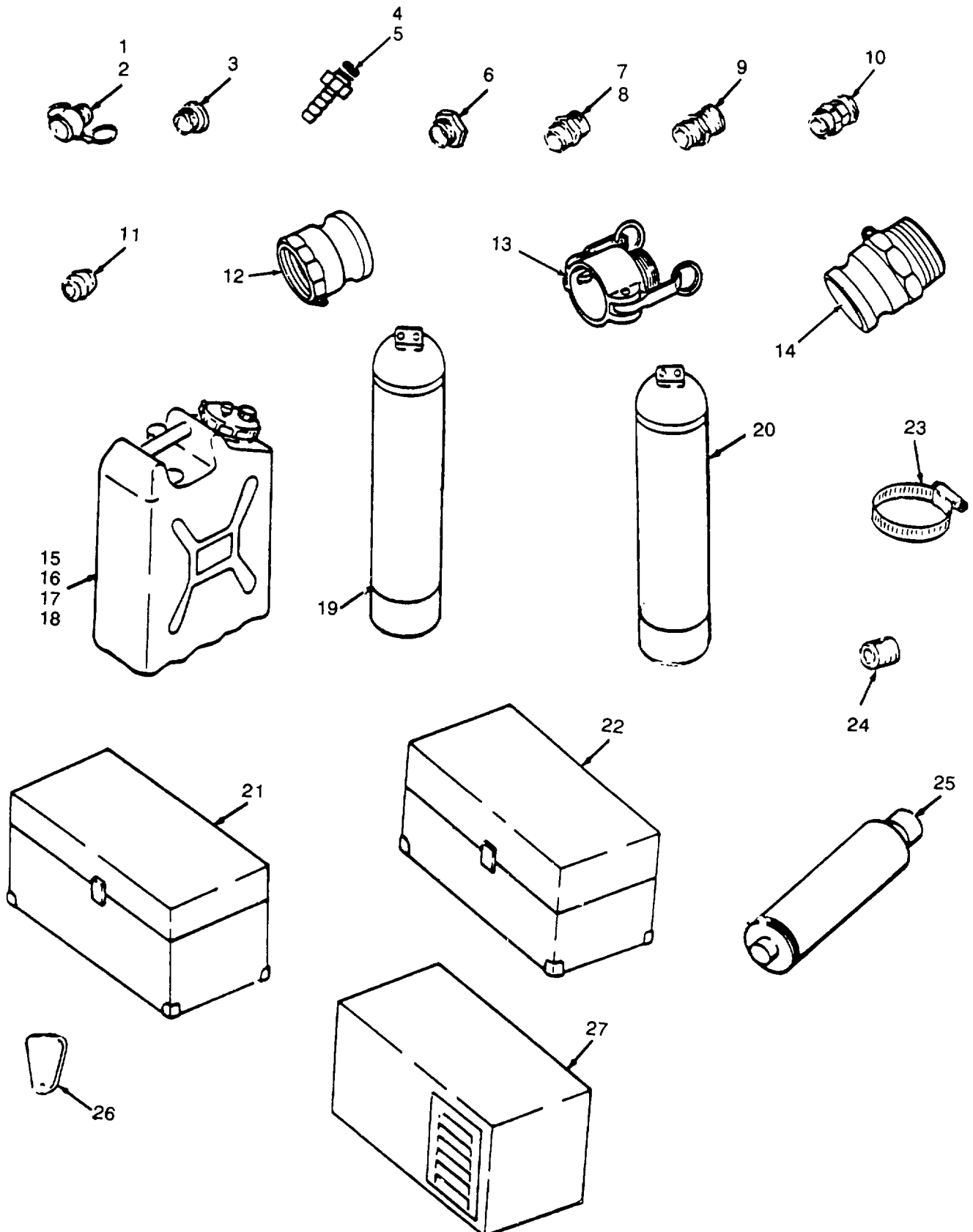

Section II. COMPONENTS OF END ITEM (continued)

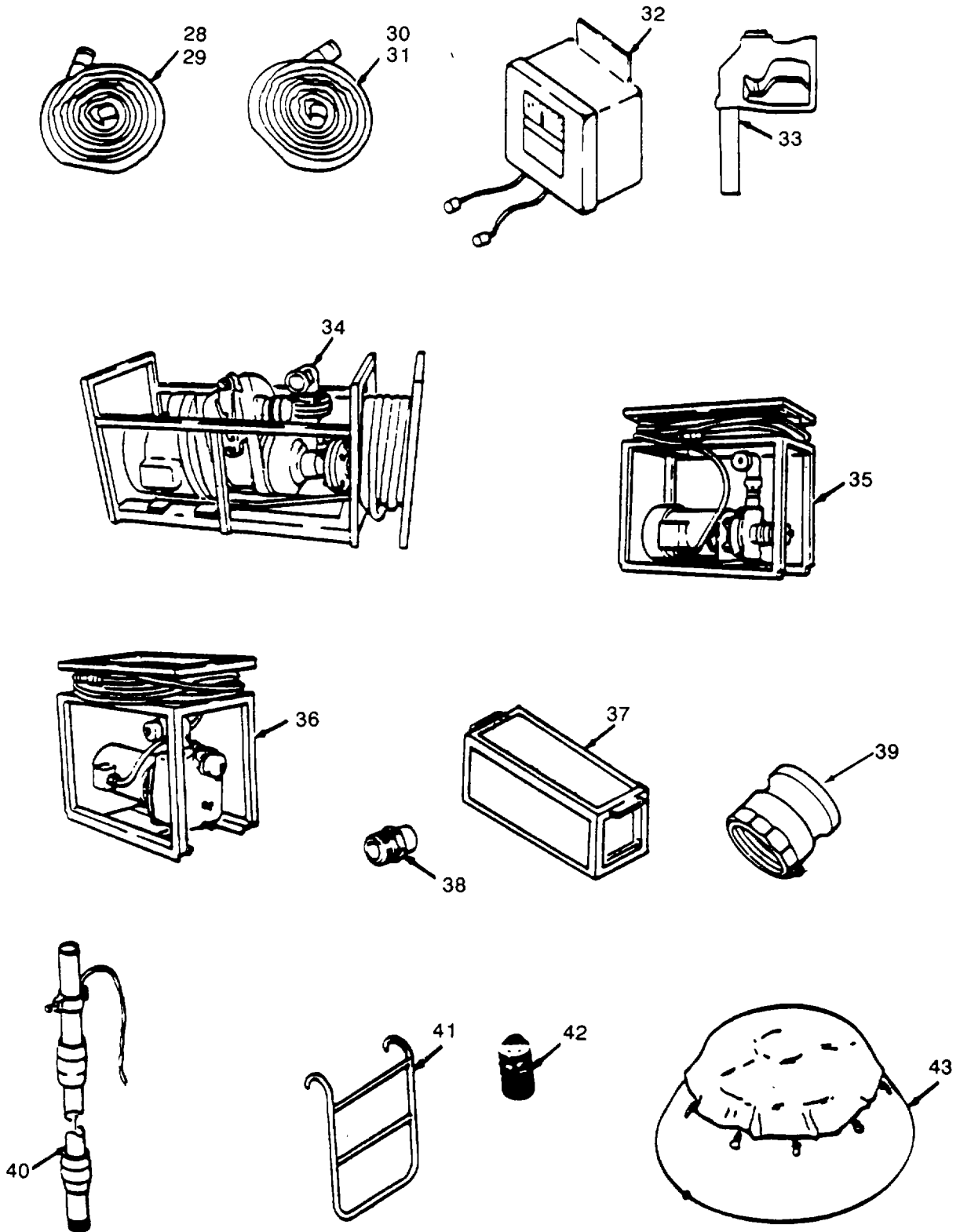

Section II. COMPONENTS OF END ITEM (continued)

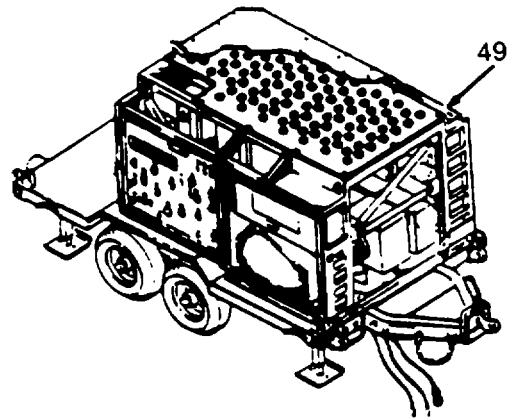
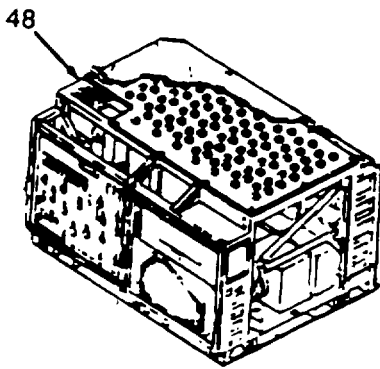
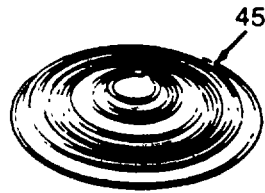
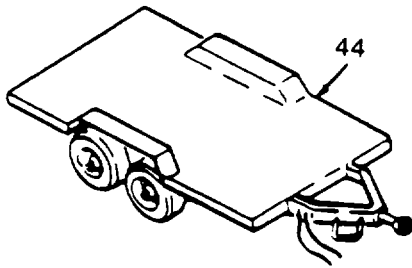

Section II. COMPONENTS OF END ITEM (continued)

LOADING PLAN STORAGE BOX-ACCESSORIES													
COMPARTMENTS		TRAYS											
<table border="1"> <tr> <td>A</td> <td>C</td> </tr> <tr> <td>B</td> <td>D</td> </tr> </table>		A	C	B	D	<table border="1"> <tr> <td>○</td> <td>○</td> <td>E</td> </tr> <tr> <td>○</td> <td>○</td> <td>F</td> </tr> </table>		○	○	E	○	○	F
A	C												
B	D												
○	○	E											
○	○	F											
QTY	UNIT	ARTICLE	COMP										
1	EA	MEYER, DISSOLVED SOLIDS	D										
9	EA	INDICATOR LAMPS, 6-8-6	F										
1	EA	EXTRACTOR, LAMP	D										
1	EA	EXTENSION LIGHT, 50 FT CORD	B										
1	EA	BULB, INCANDESCENT, 100 W	F										
1	EA	THERMOMETER, 0-220° F	F										
1	EA	STRAINER, SUCTION HOSE	A										
3	EA	GRADUATED BEAKER, 250 ML	D										
1	ROLL	TAPE, ANTI-SEIZE	D										
1	EA	MEASURE, SODIUM HEX, 0.1 LB	F										
1	EA	MEASURE, POLYELECTROLYTE, 107 ML	F										
1	EA	MEASURE, CAL. HYPOCHLORITE, 0.06 LB	F										
1	EA	FLASHLIGHT	F										
1	EA	HANDLE, SOCKET WRENCH, RACHET	B										
1	EA	ADAPTER, 2NPT EXT X 2 NPSH EXT	C										
1	EA	TOOL CASE WITH CONTENTS:	E										
1	EA	SCREWDRIVER, 2 PHILLIPS	E										
1	EA	SCREWDRIVER, 6"	E										
1	EA	SCREWDRIVER, STUBBY	E										
1	EA	PLIERS, 6"	E										
1	EA	WRENCH, PLIER	E										
1	EA	WRENCH, ADJUSTABLE, 6"	E										
1	EA	WRENCH, ADJUSTABLE, 12"	E										
2	EA	WRENCH, PIPE, ALUMINUM, 18"	E										
1	EA	BALL PEEN HAMMER 24OZ	E										
1	EA	SPANNER WRENCH, UNIV. HOSE	E										
1	EA	TOOL, PACKING ADJUSTMENT	E										
1	EA	KEY, WRENCH, SOCKET HEADSCREW, 5MM	E										
1	EA	ADAPTER, SWIVEL, 2 NPSH EXT X 1-1/2 NPSH INT	C										
2	EA	ADAPTER, 1-1/2 NPT EXT X 1-1/2 NPSH INT	C										
2	EA	ADAPTER, 1-1/2 NPSH EXT X 2 NPSH INT	C										
1	BOX	BATTERY, 9 VOLT, 2 TERMINALS	F										
1	EA	NOZZLE, PISTOL-GRIP, 1-1/2 NPT	B										
1	EA	VALVE, GATE, 1-1/2 NPT	B										
1	EA	ROPE, MANILA, 1/2 IN X 36"L	B										
1	EA	VALVE, GATE, 2-11/4 NPT	C										
1	EA	CASE, MAINTENANCE AND OPERATIONAL MAN	A										
1	EA	ADAPTER, SWIVEL, 2 NPT EXT X 2 NPSH INT	C										
1	EA	ADAPTER, STRAIGHT, 1-1/2 NPT EXT X 1-1/2 NPSH EXT	C										
3	EA	LUBRICANT, 'O' RING	F										
1	EA	PULLER, VALVE SEAT	B										
1	EA	EXTENSION, SOCKET WRENCH	B										
1	EA	HANDLE, SOCKET WRENCH, BRACE	B										
1	EA	MALLET, RUBBER	B										
8	EA	MACHINE SCREW, HEX HD	C										
7	EA	SOCKET, WRENCH, 1/2 - 15/16	B										
1	EA	WRENCH BOX AND OPEN END, 1-1/2"	E										
1	SET	WRENCH SET, COMB. BOX AND OPEN END	E										
1	EA	WRENCH, PIPE - STRAP	B										
8	EA	PLUG, PIPE, 1/2 NPT	C										
1	EA	PLUG, PIPE, 1/4 NPT	C										

STORAGE BOX 2

Section II. COMPONENTS OF END ITEM (continued)

**LOADING PLAN  
 STORAGE BOX - ACCESSORIES**

QTY	UNIT	ARTICLE	COMP
3	EA	POLYMER, 1/2 LB EA	A
8	EA	RO ELEMENT END CONNECTION AND O-RINGS	B
2	EA	SODIUM HEX, 1/2 LB EA	C
1	EA	COLOR COMPARATOR	D
5	EA	CITRIC ACID, 1/4 LB EA	E
1	EA	SOLUTION, WIDE RANGE ph, 16-oz	H
1	EA	GRADUATED PLASTIC CYLINDER, 100ml	I
5	EA	PADDLE, WOOD	J
1	EA	TRITON X 100 MEMBRANE CLEANING SOLUTION 2 LB PLASTIC BOTTLE	M
1	EA	CHLORINE, PALIN, DPD, 100 TABLETS	N
1	EA	TURBIDITY TUBE	O
1	EA	TOOL CASE WITH CONTENTS	E
1	EA	COUPLING PIPE, CORROSION RESISTANT	P
2	EA	BUSHING PIPE SHOULDER	P
4	EA	ADAPTER, POLYETHYLENE PIPE TO HOSE	P
4	EA	CLAMP, HOSE, LOW PRESSURE	P
2	EA	REDUCER ADAPTER, 1/2 NPT EXT X 1/4 NPT INT	P
2	EA	TUBING, FLEXIBLE, REINF 90.00 IN LONG	Q
1	EA	TDS MONITOR	R

STORAGE BOX 3



## SECTION III. BASIC ISSUE ITEMS

(1) ILLUS NUMBER	(2) NATIONAL STOCK NUMBER	(3) DESCRIPTION, CAGEC and Part Number	Usable On Code	(4) U/M	(5) QTY Reqd
1	5140-00-772-4142	Bag, Tool, Envelope Type: Cotton Duck; Size 4, 10 - 1/8 Inch H, 20 - 1/4 Inch Long, (81349) MIL-B-43648		EA	2
2	6135-00-850-3177	Battery, Dry: 9 Volt; 2 Terminals Snap-On Terminal; Rectangular Shape (81348) W-B-101		BX	1
3	6640-00-942-4393	Beaker, Laboratory: With Spout Borosilicate Glass, 250 ml, (81348) NNN-B-175		EA	3
4	7520-00-559-9618	Case, Maintenance and Operational Manuals; Cotton Duck, Mildew Resistant, Water, Repellent, 22 Inch H, 12.75 Inch Lg. (81349) MIL-C-11743		EA	1
5	6630-01-044-0334	Comparator, Color: (12308) U25337		EA	1
6	6640-01-086-7603	Cylinder, Graduated, Plastic: 100 ml (22527) No. 8-572D		EA	1
7	4240-00-022-2946	Ear Muff-Type Hearing Protectors		EA	1
8	6515-00-137-6345	Ear Plugs, Disposable: 400 per box		BX	1
9	5120-00-243-7326	Extension, Socket Wrench: 5 Inch Long: (81348) GGG-W-641		EA	1
10	5120-00-288-7679	Extractor, Lamp		EA	1
11	4610-01-128-6277	Filter, Tube: For Cartridge Filter: (97403) 13226E2210		EA	1
12	6230-00-264-8261	Flashlight: Type I, Style 2, (81349) MIL-F-3747		EA	1
13	5120-00-061-8545	Hammer, Hand: 1-1/2 lb Head Weight; Type 2, Style B, Class I, (81348) GGG-H-86		EA	1

Section III. BASIC ISSUE ITEMS (continued)

(1) ILLUS NUMBER	(2) NATIONAL STOCK NUMBER	(3) DESCRIPTION, CAGEC and Part Number	(4) Usable On Code U/M	(5) QTY Reqd
14	5120-00-251-4489	Hammer, Hand: 8 lb Head Weight; Double Face, Type X, Class 1, (81348) GGG-H-86	EA	1
15	5120-00-249-1071	Handle, Socket Wrench: Brace Speeder Type; 16 Inch to 20 Inch Long, (81348) GGG-W-641	EA	1
16	5120-00-230-6385	Handle, Socket Wrench: Ratchet Type Reversible; 9 Inch; (81348) GGG-W-641	EA	1
17	5120-01-045-4890	Key, Socket Head Screw: 5mm (57719) AWM-5C	EA	1
18		Lamp, Incandescent: 120 Volts, 100 Watts (96906) W-L-101/77	EA	1
19		Lamp, Incandescent: Bulb Size S-6; 6 Watts (96906) MS 15567-2	EA	9
20	6240-00-901-9755	Light, Extension: Closed End Guard w/Hook; Plastic Body w/Switch, Lamp Accommodation Incl; 50 Ft Lg; (81348) W-L-661	EA	1
21	5120-00-293-3399	Mallet, Rubber: Barrel-Shaped, 20 Oz, Type III, Class 3, (81348) GGG-H-33	EA	1
22		Manuals, Technical Operator's Maintenance Manual, 600 GPH Reverse Osmosis Water Purification Unit, TM 10-4610-240-10.  Unit, Direct and General Support Manual, 600 GPH Reverse Osmosis Water Purification Unit, TM 10-4610-240-24.  Lubrication Order, LO 10-4610-240-12		

Section III. BASIC ISSUE ITEMS (continued)

(1) ILLUS NUMBER	(2) NATIONAL STOCK NUMBER	(3) DESCRIPTION, CAGEC and Part Number	(4) Usable On Code U/M	(5) QTY Reqd
23	4610-00-542-4639	Measure, Dry Chemical, Water Purification: Plastic, Calcium Hypochlorite; 0.05 lb Graduations; 0.20 lb; (81349) MIL-M-52379, Figure 6	EA	1
24	4610-00-115-752 1	Measure, Dry Chemical, Water Purification: Sodium Hexametaphosphate; 0.1 lb; (97403) 13221E8334	EA	1
25		Measure, Liquid, Water Purification: Polyelectrolyte, 107 ml (97403) 13221E8329	EA	1
26	6630-00-127-4774	Meter, Dissolved Solids (97403) 13222E5258	EA	1
27	7330-00-972-5211	Paddle (81349) MIL-W-52482, Fig 2	EA	4
28	4610-01-088-3233	Paddle, Aluminum (97403) 13221E8328	EA	1
29	7240-00-137-1609	Pail, Utility: Plastic or Rubber, Pouring LIP, with Bail (81349) L-P-65, Size4	EA	4
30	5120-00-223-7396	Pliers, Slip-Joint: 6 Inch Lg; (81348) GGG-P471, Type 2, Style A, Class 2	EA	1
31	5120-01-135-0062	Puller, Reverse Osmosis Element: (97403) 13221E8330	EA	1
32	Rope, Fibrous: Manila Hemp; Type M	Class 1.75 Inch Dia (81348) T-R-605	FT	3
33	5305-01-088-7419	Screw, Machine-Steel, Hex HD, Slotted, Carbon Steel, CAD PLTD, ¼ - 20 UNC -2A, 2 Inch Lg, (96906) MS 51849-102	EA	8

Section III. BASIC ISSUE ITEMS (continued)

(1) ILLUS NUMBER	(2) NATIONAL STOCK NUMBER	(3) DESCRIPTION, CAGEC and Part Number	(4) Usable On Code U/M	(5) QTY Reqd
34	5120-00-234-8913	Screwdriver, Cross Tip: Phillip; Plastic Handle; No. 2 Tip; 4-Inch Blade; Type VI, Class I, Style I (81348) GGG-S-121	EA	1
35	5120-00-596-8502	Screwdriver, Flat Tip: Flared Tip; Plastic Handle; ¼ Inch Width Tip; 1 -½ Inch Nom Blade Lg; (81348) GGG-S-121, Type I, Class 3	EA	1
36	5120-00-234-8910	Screwdriver, Flat Tip: Flared, Plastic Handle; 5/16-Inch Width Tip; 6-Inch Lg Blade; (81348) GGG-S-121, Type I, Design A, Shape A	EA	1
37	5120-00-237-0984	Socket, Socket Wrench: ½-Inch (81348) GGG-W-641	EA	1
38	5120-00-235-5870	Socket, Socket Wrench: 11-16 Inch; (81348) GGG-W-41	EA	1
39	5120-00-1 89-7985	Socket, Socket Wrench: ¾-Inch; (81348) GGG-W-641	EA	1
40	5120-00-189-7934	Socket, Socket Wrench: 7/8-Inch; (81348) GGG-W-641	EA	1
41	5120-00-1 89-7932	Socket, Socket Wrench: 9/16-Inch; (81348) GGG-W-641	EA	1
42	5120-00-189-7935	Socket, Socket Wrench: 15/16-inch; (81348) GGG-W-641	EA	1
43	5120-00-189-7946	Socket; Socket Wrench: 5/8-Inch; (81348) GGG-W-641	EA	1
44	6685-01-103-9938	Thermometer, Self-Indicating; 0-2200F; 5 Inch Stem (65092) Model 2292	EA	1
45	6630-01-105-2058	Tube, Turbidity (97403) 13221E8335	EA	1

Section III. BASIC ISSUE ITEMS (continued)

(1) ILLUS NUMBER	(2) NATIONAL STOCK NUMBER	(3) DESCRIPTION, CAGEC and Part Number	Usable On Code	(4) U/M	(5) QTY Reqd
46	5120-00-148-7917	Wrench Set, Combination Box and Open End: 15 DEG Offset Box; Opening, 5/16 to 1 Inch Openings; w/Roll (81348) GGG-W-36	SET	1	
47	5120-00-264-3796	Wrench, Adjustable: Chromium Plated Open End; Single Head (81348) GGG-W-31, Type I, Class 1; Size 12	EA	1	
48	5120-00-264-3795	Wrench, Adjustable: Steel, Chromium Plated; Open End; Single Head (81348) GGG-W-63 1, Type I, Class I, Size 6	EA	1	
49	5120-00-228-9517	Wrench, Box and Open End: 1-1/2 Inch	EA	1	
50	5120-00-242-3240	Wrench. Pipe-Strap: 1/8"- 2" Pipe Size;	EA	1	
51	5120-00-277-1479	Wrench, Pipe: Adjustable Jaw, Stillson Pattern; Aluminum Alloy; 1 to 2 Inch IPS: 18 Inch Lg (81348) GGG-W-51, Type II, Class C	EA	2	
52		Wrench, Plier: Straight Jaw Style: 10 Inch Nom Lg; Type 1, Class 1, Style A (81348) GGG-W-00649	EA	1	
53	5120-00-293-1602	Wrench, Spanner: Universal Hose Couplings; 1-3 Inch Hose Coupling: 11 Inch Lg (81348) GGG-W-665	EA	2	
54	5120-00-378-4411	Wrench, Wheel Stud Nut: 1-1/2 Inch Hex Opening One End and .812 Inch Sq Opening Other End; w/Removable Handle: (87641) 151	EA	1	

Section III. BASIC ISSUE ITEMS (continued)

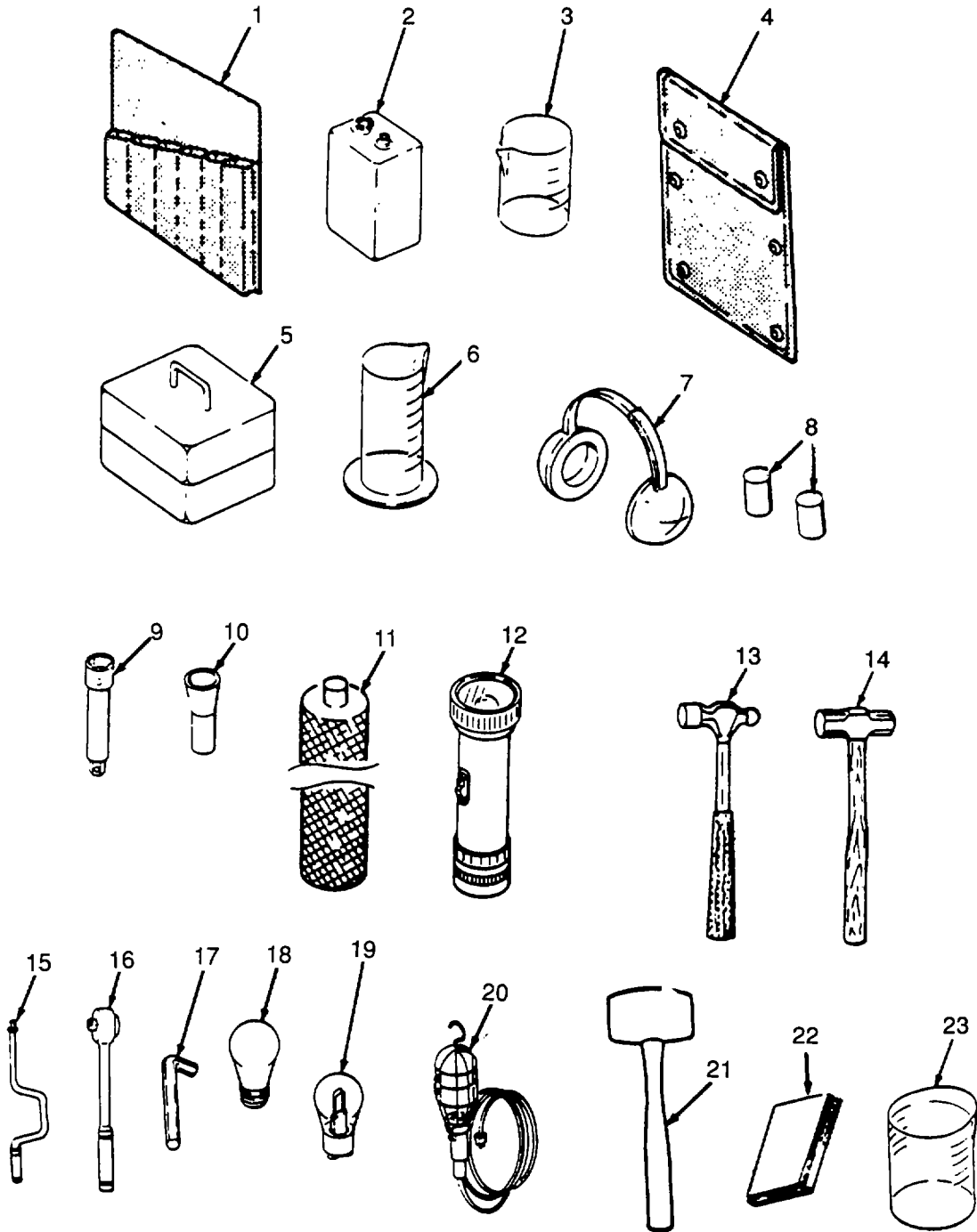

Section III. BASIC ISSUE ITEMS (continued)

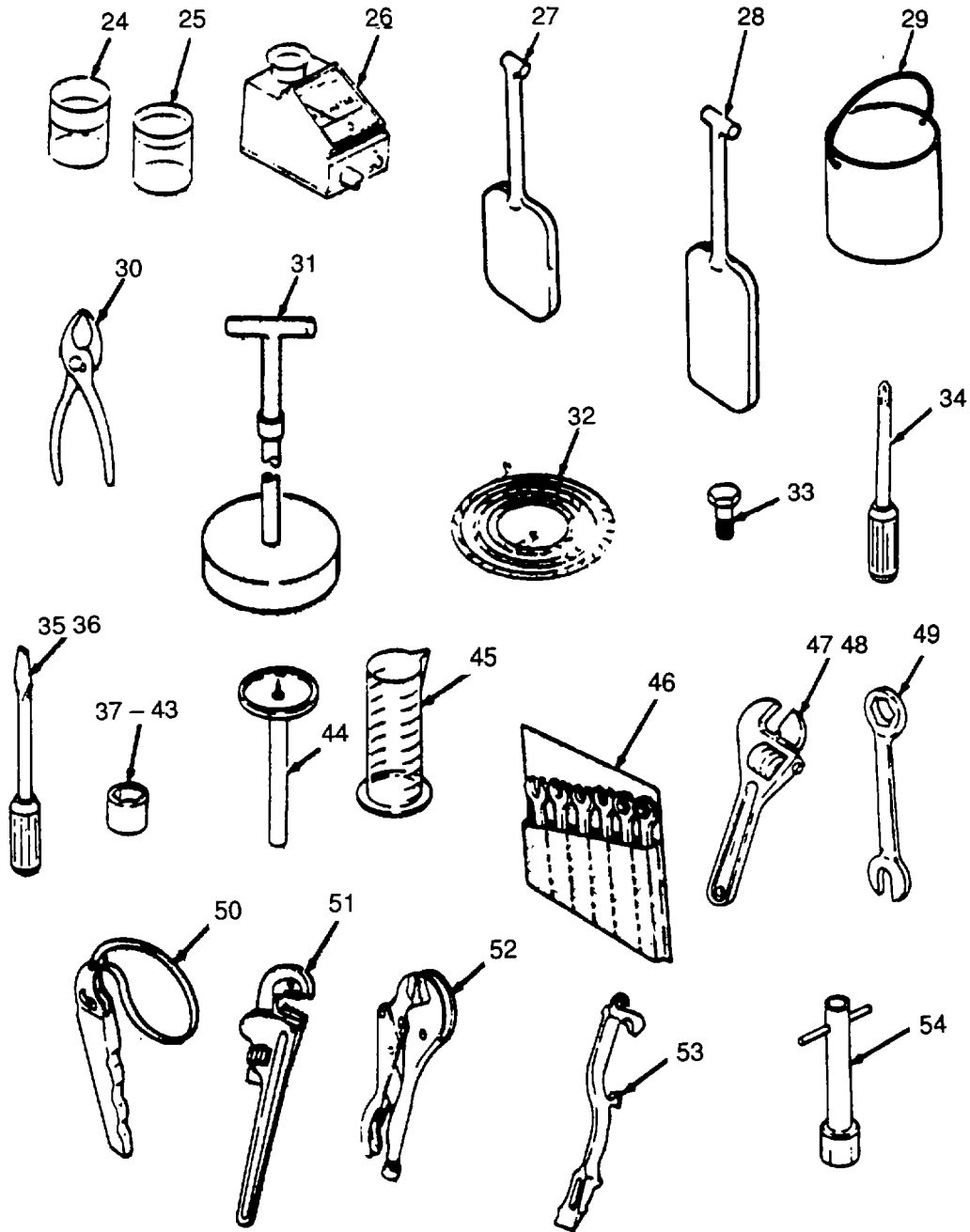

**APPENDIX C**  
**ADDITIONAL AUTHORIZATION LIST**  
**NOT APPLICABLE**



APPENDIX D

EXPENDABLE/DURABLE SUPPLIES AND MATERIALS LIST

SECTION I. INTRODUCTION

**D-1. SCOPE.** This appendix lists expendable/durable supplies and materials you will need to operate and maintain the Reverse Osmosis Water Purification Unit. This listing is for informational purposes only and is not authority to requisition the listed items. These items are authorized to you by CTA 50-970, Expendable/Durable Items (except Medical, Class V, Repair Parts, and Heraldic Items), or CTA 8-100, Army Medical Department Expendable/Durable Items.

**D2. EXPLANATION OF COLUMNS**

a. Column (1) - Item Number. This number is assigned to the entry in the listing and is referenced in the narrative instructions to identify the material (e.g., Use cleaning compound, item 5, appendix C).

b. Column (2) - Level. This column identifies the lowest level of maintenance that requires the listed item.

- C - Operator/Crew
- O - Unit Maintenance
- F - Direct Support Maintenance
- H - General Support Maintenance

c. Column (3) - National Stock Number. This is the National Stock Number assigned to the item; use it to request or requisition the item.

d. Column (4) - Description. Indicates the Federal item name, and, if required, a description to identify the item. The last line for each item indicates the Commercial and Government Entity Code (CAGEC) in parentheses followed by the part number.

e. Column (5) - Unit of Measure (U/M). Indicates the measure used in performing the actual maintenance function. This measure is expressed by a two-character alphabetical abbreviation (e.g., EA, IN, PR). If the unit of measure differs from the unit of issue, requisition the lowest unit of issue that will satisfy your requirements.

**Section II. EXPENDABLE/DURABLE SUPPLIES AND MATERIALS LIST**

(1) ITEM NUMBER	(2) LEVEL	(3) NATIONAL STOCK NUMBER	(4) DESCRIPTION  PART NO. AND FSCM	(5) UNIT OF MEAS.
1	F	8040-00-262-9005	Adhesive (81348) MMM-A-1617, Type 11	TB
2	O	5610-01-355-7780	Anthracite, No. 2 (76371) 5100191000 (Used with MECO Multimedia Filter <b>OR</b> CULLICITE (350 lbs required) (71726) 1610 (Used with Culligan Multimedia Filter)	LB

SECTION II. EXPENDABLE/DURABLE SUPPLIES AND MATERIALS LIST (continued)

(1) ITEM NUMBER	(2) LEVEL	(3) NATIONAL STOCK NUMBER	(4) DESCRIPTION  PART NO. AND FSCM	(5) UNIT OF MEAS.
3	O	6810-00-238-8115	Calcium Hypochlorite, Technical: 3-3/4 lb Plastic Bottle (81348) O-C114, Type I	EA
4	O	6810-01-044-0315	Chlorine Test Tablets: Palin, DPD Chlorine #1: 100 Per Box; (79172) U-251 0	PG
5	O	6810-01-164-3975	Citric Acid, Anhydrous, Technical: Crystalline; 3/4 Lb Plastic Bottle; (81349) MIL-C-52947	BT
6	F	8305-00-059-5074	Cloth, Cheesecloth	LB
7	O	6850-01-167-5318	Coagulant Liquid, Water Treatment: 2.35 lb Plastic Bottle; (81549) MIL-1-52701	BT
8	O	7930-00-282-9699	Detergent, GP, Uq, WS, A (81349) MIL-D- 16791	GL
9	O	5610-01-355-7783	Garnet, Course, No.12 (170 lbs required) (76371) 5100188000 (Used with MECO Multimedia Filter <b>OR</b> CULLSAN G-1 2 '(175 lbs required) (71626)1633 (Used with Culligan Multimedia Filter)	LB
10	O	5610-01-355-7782	Garnet, Fine No. 50 (180 lbs required) (76371) 5100189000 <b>OR</b> CULLSAN G-50 (175 lbs required) (71626) 1630 (Used with Culligan Multimedia Filter)	LB
11	O	5610-01-355-7784	Gravel, 1/4-inch (245 lbs required) (76371) 5100187000 (Used with MECO Multimedia Filter <b>OR</b> CULLSAN Medium (250 lbs required) (71726)1621 (Used with Culligan Multimedia Filter)	LB
12	O		Grease, 35-616	LB
13	O	9150-00-190-0904	Grease, Automotive and Artillery, GM (81349) MIL-G-1 0924	EA
14	O	9150-01-161-4600	Grease, Silicone (71984) DC-18	TB
15	O	6810-00-087-2340	Indicator Solution, pH Wide Range 16 Oz Plastic Bottle (81349) MIL-1-52701	EA

Section II. EXPENDABLE/DURABLE SUPPLIES AND MATERIALS LIST (continued)

(1) ITEM NUMBER	(2) LEVEL	(3) NATIONAL STOCK NUMBER	(4) DESCRIPTION  PART NO. AND FSCM	(5) UNIT OF MEAS.
16	O	6810-01-359-4919	Glycerin, 250 cc (97403) 13229E01 72	BT
17	O	5610-01-355-1303	Media, Plastic (60 lbs required) (76371) 5100190000 (Used with MECO Multimedia Filter <b>OR</b> CULLSAN P (50 lbs required) (71726) 1631 (Used with Culligan Multimedia Filter)	LB
18	O	9150-01-035-5395	Oil, Lubricating (81349) MIL-L-21 05	GL
19	O	9150-01-152-4117	Oil, Lubricating, Internal Com- bustion Engine (81349) MIL-L-2104	GL
20			<b>DELETED</b>	
21	O	7920-00-205-1711	Rags, Wiping (58536) A-A-531	LB
22	O	5610-01-355-7781	Sand, Filter (230 lbs required) (76371) 5100191000 (Used with MECO Multimedia Filter) <b>OR</b> CULLSAN A (225 lbs required) (71726) 1632 (Used with Culligan Multimedia Filter)	LB
23	O	5350-01-279-6314	Sanding Strip, Abrasive (77068)8225A25	EA
24	O	6810-01-164-3941	Sodium Hexametaphosphate, Technical, 2 LB Plastic Bottle (81349) MIL-S-51 078	BT
25	F	6850-00-664-5685	Solvent, Drycleaning (81349) PD-680	GL
26	O	6850-01-163-7635	Wetting Agent, Liquid Anhydrous, Non- ionic (Isooctylphenoxypolyethoxyethanol); 10 Moles Ethylene Oxide; 2 LB Plastic Bottle (77902)	BT
27	O	8030-00-889-3534	Tape, Antseize, Roll (81349) MIL-T-27730	EA
28	O	5970-00-147-5674	Tape, Electrical, Roll (81349) MIL-1-24391	EA
29	O		Tape Insulating (NOMEX) (97403) 13221E8320-4	EA
30	O	4020-00-138-7042	Twine, Ball (81349) MIL-T-713	EA

\*U.S. GOVERNMENT PRINTING OFFICE: 1995 388-421/42171

Change 1 D-3/(D-4 blank)

INDEX

Subject	Paragraph	Page
<b>A</b>		
Additional Authorization List .....	Appendix C	C-1
After Operation Preventive Maintenance Checks and Services.....	2-19c	2-18
Air Brake.....	2-2	2-1
Auxiliary Equipment.....	2-32, 4-1	2-85, 4-1
<b>B</b>		
Backwash of Multimedia Filter .....	2-26	2-75
Backwash Pump		
Location and Description .....	1-16b	1-2
Operation.....	2-26	2-75
Backwash Pump Switch .....	2-6	2-2
Backwash Strainer		
Removal.....	3-6a	3-25
Cleaning.....	3-6b	3-25
Installation .....	2-22p, 3-6c	2-44, 3-26
Backwash Timer (Solid State) .....	2-18, 2-26b	2-18, 2-76
Backwash Valve .....	Table 2-1, Key 6	2-7
Backwash Water Flow Meter .....	Table 2-1, Key 14	2-7
Before Operation Preventive Maintenance Checks and Services.....	2-19a	2-18
Booster Pump		
Location and Description .....	1-6e	1-12,1-13
Operation.....	2-25	2-60
Booster Pump Switch .....	2-6	2-2
Brake System .....	2-2	2-1
<b>C</b>		
Cables, power.....	2-22ad	2-53
Calcium Hypochlorite, mixing .....	2-22w	2-50
Calibration		
Chemical Feed Pump.....	2-25g-i	2-63
TDS Meter .....	2-32c	2-86
Canvas Covers .....	1-6c	1-8
Cartridge Filter		
Location and Description .....	1-6e	1-12
Maintenance.....	3-5	3-23

INDEX (continued)

Subject	Paragraph	Page
Cartridge Filter Gage .....	Table 2-1, Key 21	2-8
Cartridge Filter Tube Elements .....	3-5	3-23
Chemical Contaminated Areas.....	2-42	2-104
Chemical Feed Pump		
Adjustment .....	2-25g-j	2-63, 2-64
Valves.....	2-13	2-13
Controls .....	2-10	2-12
Location and Description.....	1-6e	1-12, 1-13
Operation.....	2-25	2-60
Chemical Feed Pump Switch .....	2-6	2-2
Chlorine, mixing.....	2-22x	2-50
Choosing the Site .....	2-21	2-31
Circuit Breakers.....	2-7	2-2
Citric Acid, mixing.....	2-22y	2-51
Cold Weather Operations.....	2-37	2-99
Color Comparator Kit.....	2-17	2-17
Components of End Item List.....	Appendix B	B-1
Control Box Assembly .....	2-6	2-2
Controls and Indicators .....	2-1	2-1
Control Panel.....	2-5	2-2

D

Distribution Pump		
Location and Description.....	1-6b	1-2
Operation.....	2-25ac	2-74
Distribution Pump Switch.....	2-6	2-2
Drain Valves .....	2-12	2-13
During Operation Preventive Maintenance Checks and Services.....	2-19b	2-18
Dusty and Sandy Areas.....	2-39	2-103

E

EIR .....	1-4	1-1
Electrical Plug, Trailer.....	2-1	2-1
Emergency Shutdown Procedures.....	2-24, 2-25	2-59, 2-60
End Cap Removal .....	3-4c	3-17
Equipment Characteristics, Capabilities and Features.....	1-5	1-1
Equipment Data.....	1-7	1-15
Expendable Supplies and Materials List.....	Appendix D	D-1

**INDEX (continued)**

<b>Subject</b>	<b>Paragraph</b>	<b>Page</b>
<b>F</b>		
Float .....	1-6b	1-2
Fording .....	2-34	2-99
<b>G</b>		
Gages		
Location and Description .....	2-5	2-2
Normal and Trouble Point Reading .....	2-25x	2-72
Gate Valves .....	2-11	2-12
Generator Set .....	1-6c	1-9
Ground Rod		
Location and Description .....	1-6c	1-8
Installation .....	2-22ab, 2-22ac	2-52
<b>H</b>		
Hand Receipt .....	1-3	1-1
High Pressure Relief Valve .....	2-24a	2-59
Hose Installation		
Backwash .....	2-22q	2-45
Product Water .....	2-22s	247
Raw Water .....	2-22p	2-44
Vent Vessels .....	2-22t	2-48
Waste Water .....	2-22t	2-48
Hot Weather Operations .....	2-38	2-103
<b>I</b>		
Indicator Lamps, Maintenance .....	3-10	3-29
Initial Adjustment and Checks .....	2-23	2-54
Installation		
Cartridge Filter Tube Elements .....	3-5c(Army)	3-24
R.O. Elements .....	3-4h	3-19
Rupture Disc .....	3-7	3-27
Jog Switch .....	2-6	2-2
Junction Box .....	1-6c	18

INDEX (continued)

Subject	Paragraph	Page
<b>K</b>		
<b>Not Applicable</b>		
<b>L</b>		
Lamps, Maintenance .....	3-10	3-29
Leveling Jacks .....	2-3	2-2
Location and Description of Major Components .....	1-6	1-2
Low Pressure Lamp .....	Table 2-1, Key 24	2-8
Lubrication Instructions .....	3-1	3-1
<b>M</b>		
Maintenance of Auxiliary Equipment .....	4-1	4-1
Maintenance Forms and Records .....	1-2	1-1
Maintenance Procedures		
Backwash Pump Strainer .....	3-6	3-25
Cartridge Filter .....	3-5	3-23
Indicator Lamps .....	3-10	3-29
Panel Light .....	3-11	3-30
R.O. Elements .....	34	3-16
Rupture Disc .....	3-7	3-27
Tanks, Water .....	3-8	3-28
TDS Meter .....	3-9	3-28
Monthly Operation Preventive Maintenance Checks and Services .....	2-20b	2-19
Multimedia Filter		
Backwash Timer .....	2-26b	2-75
Location and Description .....	1-6e	1-12
Multimedia Filter Gage		
Location .....	2-5	2-2
Normal and Trouble Point Reading .....	2-25x	2-72
<b>N</b>		
Normal Shutdown Procedures .....	2-31	2-83
Nuclear Biological, and Chemical Contaminated Areas .....	2-42	2-104

INDEX (continued)

Subject	Paragraph	Page
<b>O</b>		
Oil Level		
Chemical Feed Pump.....	3-1	3-1
R.O. Pump.....	3-1	3-1
Operating Procedures .....	2-25	2-60
Operation of Auxiliary Equipment .....	2-32	285
Operations Under Unusual Conditions .....	Section IV	2-99
Operator's Controls and Indicators .....	2-1	2-1
<b>P</b>		
Panel Light		
Location.....	2-5, 2-6	2-2
Maintenance.....	3-11	3-30
Piping Identification .....	1-8	1-17
Polymer, mixing.....	2-22w	2-31
Power Cables .....	2-22ad	2-53
Preparation for Movement.....	2-33	2-88
Pressure Relief Valve, High.....	2-24a	2-59
Preventive Maintenance Checks and Services.....	2-19	2-18
Principles of Operation .....	1-9	1-17
Priming Valves, Chemical Feed Pump		
Location and Description.....	16e	1-12
Operation.....	2-13	2-13
Product Water Flow Meter.....	2-4.1	2-2
Product Water Totalizer.....	2-30	2-83
Pulse Dampener		
Location and Description.....	1-6e	1-12

**Q**

NOT APPLICABLE



INDEX (continued)

Subject	Paragraph	Page
<b>R</b>		
Rainy and Damp Areas .....	2-40	2-103
Raw Water Flow Gage		
Location and Description .....	2-5	2-2
Normal and Trouble Point Reading .....	2-25x	2-72
Raw Water Pumps		
Location and Description .....	1-6b	1-2
Operation .....	2-25	2-60
Raw Water Pump Switch .....	2-25	2-60
Regulate Product Flow Valve		
Location and Description .....	2-5	2-2
Operation .....	2-23, 2-25u-v	2-54, 2-71
References .....	Appendix A	A-1
Reporting Equipment Improvement Recommendations .....	1-4	1-1
Reset Switch .....	2-6	2-2
Reset Locked Air Brakes .....	2-35	2-99
R.O. Elements		
Cleaning .....	2-28	2-79
Maintenance .....	3-4	3-16
Rinse .....	2-28	2-79
R.O. Element Puller .....	3-4d	3-17
R.O. Element Cleaning Switch .....	2-6	2-2
Operation .....	2-29	2-79
R.O. Pressure P.S.I. Meter .....	2-5	2-2
R.O. Pressure Vessels		
Location .....	1-6e	1-12
Maintenance .....	3-4	3-16
R.O. Pump		
Location and Description .....	1-6e	1-12
Operation .....	2-25n	2-66
R.O. Pump High Pressure Lamp .....	2-25b(1)	2-60
R.O. Pump Low Pressure Lamp .....	2-25b(2)	2-60
R.O. Vessels Gage		
Location and Description .....	2-6	2-2
Normal and Trouble Point Reading .....	2-25x	2-72
Rupture Disc Assembly		
Location and Description .....	2-24c	2-59
Maintenance .....	3-7	3-27

INDEX (continued)

Subject	Paragraph	Page
<b>S</b>		
Safety Valves.....	2-24	2-59
Saltwater Areas .....	2-103	
Scope .....	1-1	1-1
Shutdown Procedures .....	2-31	2-83
Site Selection.....	2-21	2-31
Sodium Hex, mixing .....	2-22y	2-51
Storage Boxes.....	2-22g, Appendix B	240,B-2
Switches, Location and Function.....	2-6	2-2
Swivel Assembly.....	2-3	2-2
<b>T</b>		
Tanks, Water		
Installation .....	2-22o	2-44
Maintenance.....	3-8	3-28
TDS Meter		
Location and Description.....	2-14	2-14
Operation.....	2-32c	2-86
Calibration (Maintenance) .....	2-32c,3-9a	2-86, 3-28
Installation .....	2-15a	5a2-15
Removal .....	2-15b	2-15
Technical Principles of Operation.....	1-9	1-17
Trailer Lights.....	2-1	2-1
Troubleshooting Procedures .....	3-2	3-1
Turbidity Tube.....	2-16	2-16
<b>U</b>		
<b>NOT APPLICABLE</b>		
<b>V</b>		
Valves		
Backwash .....	Table 2-1, Key 6	2-7
Chemical Feed Pump.....	2-13	2-13
Drain .....	2-12	2-13
Gate.....	2-11	2-12
Product Water Flow, Regulate .....	Table 2-1, Key 17	2-7
Vent Vessels .....	2-8	2-11

**INDEX (continued)**

<b>Subject</b>	<b>Paragraph</b>	<b>Page</b>
Vent Cartridge Filter Valve .....	Table 2-1, Key 3	2-7
Vent Multimedia Filter Valve.....	Table 2-1, Key 5	2-7
Vent Product Water Valve .....	2-9	2-11
Vent Pulse Dampener Valve .....	Table 2-1, Key 4	2-7
Vent Vessels Valve		
Location and Description .....	2-8	2-11

**W**

Water Processing and Chemicals .....	1-9	1-17
Water Tanks		
Installation .....	2-22o	2-44
Maintenance.....	3-8	3-28
Weekly Operation Preventive Maintenance Checks and Services .....	2-20b(2)	2-19

**X**

**NOT APPLICABLE**

**Y**

**NOT APPLICABLE**

**Z**

**NOT APPLICABLE**

**Index-8**

By Order of the Secretaries of the Army and Navy (Including the Marine Corps):

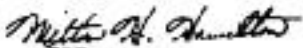
Official: 

MILTON H. HAMILTON  
*Administrative Assistant to the  
Secretary of the Army*  
02121

GORDON R. SULLIVAN  
*General, United States Army  
Chief of Staff*

**DAVID E. BOTTORFF**  
*Rear Admiral, CEC, US Navy  
Commander  
Navy Facilities Engineering Command*

**H. E. REESE**  
*Deputy for Support  
Marine Corps Research, Development and  
Acquisition Command*

DISTRIBUTION:

To be distributed in accordance with DA Form 12-25E, (qty rqr block no. 4487).

\*U.S. GOVERNMENT PRINTING OFFICE: 1992 654-122/40066

RECOMMENDED CHANGES TO EQUIPMENT TECHNICAL PUBLICATIONS



THEN... JOT DOWN THE DOPE ABOUT IT ON THIS FORM, CAREFULLY TEAR IT OUT, FOLD IT AND DROP IT IN THE MAIL!

**SOMETHING WRONG WITH THIS PUBLICATION?**

FROM: (PRINT YOUR UNIT'S COMPLETE ADDRESS)

DATE SENT

PUBLICATION NUMBER

PUBLICATION DATE

PUBLICATION TITLE

BE EXACT... PIN-POINT WHERE IT IS

IN THIS SPACE TELL WHAT IS WRONG AND WHAT SHOULD BE DONE ABOUT IT:

PAGE NO.	PARA-GRAPH	FIGURE NO.	TABLE NO.
----------	------------	------------	-----------

TEAR ALONG PERFORATED LINE

PRINTED NAME, GRADE OR TITLE, AND TELEPHONE NUMBER

SIGN HERE:

DA FORM 2028-2 JUL 79

PREVIOUS EDITIONS ARE OBSOLETE.

P.S.—IF YOUR OUTFIT WANTS TO KNOW ABOUT YOUR RECOMMENDATION MAKE A CARBON COPY OF THIS AND GIVE IT TO YOUR HEADQUARTERS.



**THE METRIC SYSTEM AND EQUIVALENTS**

**LINEAR MEASURE**

1 Centimeter 10 Millimeters 0.01 Meters 0.3937 Inches  
 1 Meter 100 Centimeters 1,000 Millimeters 39.37 Inches  
 1 Kilometer 1,000 Meters 0.621 Miles

**SQUARE MEASURE**

1 Sq Centimeter 100 Sq Millimeters 0.155 Sq Inches  
 1 Sq Meter 10,000 Sq Centimeters 10.76 Sq Feet  
 1 Sq Kilometer 1,000,000 Sq Meters 0.386 Sq Miles

**WEIGHTS**

1 Gram 0.001 Kilograms 1,000 Milligrams 0.035 Ounces  
 1 Kilogram 1,000 Grams 2.2 Lb  
 1 Metric Ton 1,000 Kilograms 1 Megagram 1.1 Short Tons

**CUBIC MEASURE**

1 Cu Centimeter 1,000 Cu Millimeters 0.06 Cu Inches  
 1 Cu Meter 1,000,000 Cu Centimeters 35.31 Cu Feet

**LIQUID MEASURE**

1 Milliliter 0.001 Liters 0.0338 Fluid Ounces  
 1 Liter 1,000 Milliliters 33.82 Fluid Ounces

**TEMPERATURE**

5/9 ( F - 32 ) C  
 212 Fahrenheit is equivalent to 100 Celsius  
 90 Fahrenheit is equivalent to 32.2 Celsius  
 32 Fahrenheit is equivalent to 0 Celsius  
 9/5 C + 32 = F

**APPROXIMATE CONVERSION FACTORS**

TO CHANGE	TO	MULTIPLY BY
Inches	Centimeters	2.540
Feet	Meters	0.305
Yards	Meters	0.914
Miles	Kilometers	1.609
Square Inches	Square Centimeters	6.451
Square Feet	Square Meters	0.093
Square Yards	Square Meters	0.836
Square Miles	Square Kilometers	2.590
Acres	Square Hectometers	0.405
Cubic Feet	Cubic Meters	0.028
Cubic Yards	Cubic Meters	0.765
Fluid Ounces	Milliliters	29.573
Pints	Liters	0.473
Quarts	Liters	0.946
Gallons	Liters	3.785
Ounces	Grams	28.349
Pounds	Kilograms	0.454
Short Tons	Metric Tons	0.907
Pound-Feet	Newton-Meters	1.356
Pounds per Square Inch	Kilopascals	6.895
Miles per Gallon	Kilometers per Liter	0.425
Miles per Hour	Kilometers per Hour	1.609

TO CHANGE	TO	MULTIPLY BY
Centimeters	Inches	0.394
Meters	Feet	3.280
Meters	Yards	1.094
Kilometers	Miles	0.621
Square Centimeters	Square Inches	0.155
Square Meters	Square Feet	10.764
Square Meters	Square Yards	1.196
Square Kilometers	Square Miles	0.386
Square Hectometers	Acres	2.471
Cubic Meters	Cubic Feet	35.315
Cubic Meters	Cubic Yards	1.308
Milliliters	Fluid Ounces	0.034
Liters	Pints	2.113
Liters	Quarts	1.057
Liters	Gallons	0.264
Grams	Ounces	0.035
Kilograms	Pounds	2.205
Metric Tons	Short Tons	1.102
Newton-Meters	Pound-Feet	0.738
Kilopascals	Pounds per Square Inch	0.145
Kilometers per Liter	Miles per Gallon	2.354
Kilometers per Hour	Miles per Hour	0.621

PIN: 070219-002